

User manual

IRON DOG 02

©2021

BRUNNER[®]
made in germany.

Iron Dogs

are cast Iron stoves made in Germany, manufactured by a family business in the 3th generation, specialized in making fireplaces. In this series all their knowledge and craftsmanship come together in an exceptional stove of an exceptional quality. Therefore also the exceptional name »IRON DOG« for exceptional people or as a gift to friends.

Winter can come; we're looking forward to it.

Welcome to the IRON DOG family.

Eggenfelden, August 2007



Ulrich Brunner

The name >>EISERNER HUND<< - >>IRON DOG<< - is a registered and protected mark. Individual models are registered as design patents.

CONTENTS

1	My Iron Dog.....	4
2	Technical Data.....	5
3	Safety guidelines.....	10
4	Basic principles.....	11
5	Firewood and heating power.....	14
6	Seasoning of firewood.....	16
7	Amount of fuel.....	17
8	Operation.....	18
9	Heating with the Iron Dog.....	19
10	Ashes.....	21
11	Cleaning and maintenance.....	22
12	Hint.....	23
13	Error search.....	24
14	Attention.....	26

IRON DOG

Please read the entire User Guide before lighting the fire for the first time. In particular, please note the safety precautions in this manual. The User Guide, as well as national or EU standards and local regulations must be observed. Your specialized enterprise and **IRON DOG** partner can give you the most current information and details.

Please keep the User Guide for future reference!

1 MY IRON DOG

An **EISERNER HUND** is a special cast iron stove. It's a friend for life. Its life expectancy is about generations and it will do good services to its owners – therefore treat it well.

Nearly all components of the **IRON DOG** are made of solid cast iron. Ash boxes, screws and bolts are made of stainless steel. A special, temperature-firm color coating protects the surface. All components of this cast iron stove are manufactured and assembled in Germany with great care

2 TECHNICAL DATA

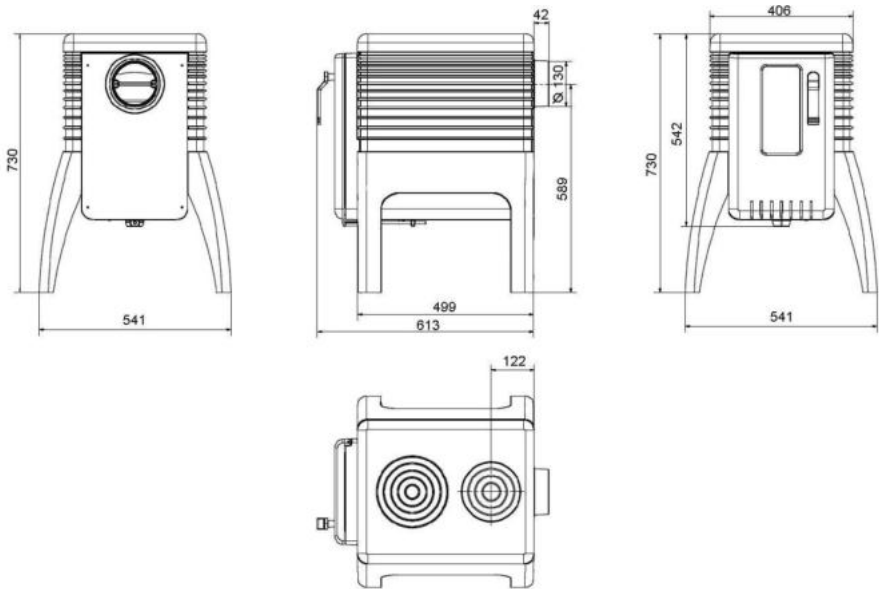

Illustration 1: measurements

- 1 Ash pan
- 2 Air control push rod
- 3 Fire chamber
- 4 Identification plate
- 5 Hot plate
- 6 Hot plate cover



- | | | | |
|------|--------------------------|------|------------------------------|
| 1 | Leg | 2 | Hot plate |
| 3 | Side wall left | 4 | Side wall right |
| 5 | Floor plate | 6 | Back wall |
| 8 | Exhaust gas stub | 9 | Baffle plate |
| 10 | Bottom grate assembly | 10.1 | Bottom grate wood |
| 10.2 | Slide valve | 10.4 | Bottom grate frame |
| 11 | BG air control | 12 | Air channel cover |
| 13 | Front | 14 | Ash pan |
| 15 | Firing door assembly | 15.1 | Fire door |
| 15.2 | Heat shield firing door | 15.3 | Lower heat shield door |
| 15.4 | Firing door window | 15.6 | Door handle assembly |
| 15.7 | Closing tongue | 16 | Air channel front |
| 17 | Air channel back cover | 19 | Air control rod |
| 29 | Back wall firing chamber | 30 | Blanking cover for flue exit |

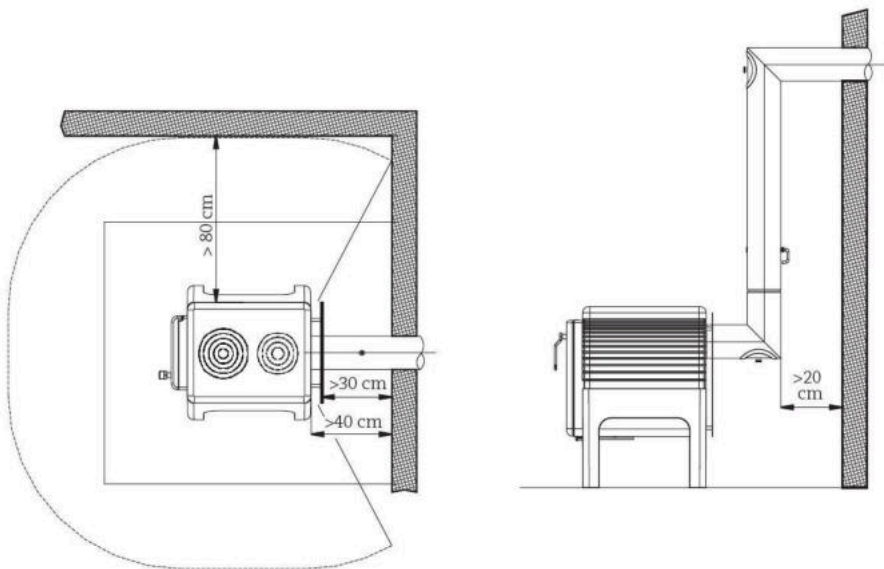

Illustration 3: minimum distances

values¹⁾

nominal heat output	kW	7
flue gas stream	g/s	7,6
flue gas temperature (at port)	°C	353
necessary draft	Pa	12
consumption/h	kg	2
space heating capacity	m ³	50 - 90
degree of efficiency	%	80,6
combustion air consumption	m ³ /h	15

appliance data

dimension (h x w x d)	mm	730 x 540 x 610
glass pane surface (h x w)	mm	245 x 105
combustion chamber opening (h x w)	mm	250 x 210
flue diameter		Rückwand
permitted fuel quantity	kg	1,5 - 2,5
combustion chamber dept	cm	40
recommended log length	cm	25 / 33
cast iron weight	kg	150

required minimum distances

to the side wall	cm	80
to the rear wall (with insulation panel)	cm	30
to the rear wall (without insulation panel)	cm	40

approvals

CE nach EN 13240

1) the data was determined in an EN 13240 test with a chimney stove with a horizontal smoke tube connection, tube length 35 cm.

3 SAFETY GUIDELINES



Radiation range

Do not bring inflammable materials within an 80 cm radiation range of the **IRON DOG!** Fire risk! Don't put inflammable objects on the stove top, under the cast iron stove or in between the rear of the stove and the wall behind.



First starting-up

Up to the first reaching of the maximum operating temperature the protective paint hardens out. This can give some smelling nuisances. Provide therefore for sufficient ventilation of the installation area. Open doors and windows. Don't stay unnecessarily in the concerned area. Never use products as gasoline, white spirits or the like to start a fire!



Burning risk

The external surfaces of the **IRON DOG** become hot, especially the window of the fire door.

Don't touch – Burning risk!

Particularly warn children for this. Keep children away from the heated **IRON DOG**.

Use safety gloves during operation.



Ashes

Empty the ash pan only when the ashes are cold and keep them during at least 24 h in a fire resistant container. Fire risk by remaining glow! In case of fire, call the fire-brigade!



Chimney fire

In case of a chimney fire, remove all inflammable objects from the chimney. Beware of flying sparks. Call the fire-brigade!



Fire door

The fire door of the **IRON DOG** may only be opened for bringing in wood or for cleaning. During use with open fire door, the stove is too heavily charged, smoke or fire can come out and glowing particles can be ejected. There is the danger of a flue gas poisoning. The fire chamber of the **IRON DOG** is also to be kept closed when the stove is not heated.

4 BASIC PRINCIPLES

Cast iron stoves of the **IRON DOG** series function according to the principal of 'burning from above' and are heated with the intermittent burning method. The wood load degases with beautiful flames in approximately 60 - 70 minutes and produces a heating output between 5 - 9 kW/h depending on the quantity of wood (1,5 kg - 2,5 kg).

Cast iron stoves of the **IRON DOG** series are tested according to EN 13240 / EN 12815 and can be used with a closed fire door. Connecting more than one stove to a chimney is possible if the chimney is suited for this (ask the chimney sweep).

Air supply to the setting up area

The **IRON DOG** can only function properly when the combustion air supply at the setting up area is sufficient. Before heating up make sure there is a sufficient supply of fresh air. In the building existing mechanisms for combustion air supply should not be changed.

Fuel

Use only suitable burning wood in the indicated quantities and qualities. Too small amounts of burning wood lead to insufficient combustion quality. Too large amounts of burning wood lead to overheating and damage to the equipment. Fire risk!

Heat output

The cast iron stoves of the **IRON DOG** series are designed to be used with the intermittent wood burning method; the heat output is determined by the quantity of wood used and by the distances in time between the firing operations. The right time to put on more wood has come when the wood has nearly been burned down to glow.

Combustion air regulation

For a simple operation the air income is regulated with one single air control rod. Please heat with the given combustion air regulations. Insufficient combustion air leads to an increased environmental impact, bad efficiency and creosote in the stove and the chimney.

Heating operation

We recommend using safety gloves during operation, since the operating elements become hot. Open the door slowly – this way no turbulences develop, which let flue gases escape.

Flue exhaust/heating during transitional periods

The **IRON DOG** needs sufficient chimney draught for drawing in the combustion air and exhausting the flue gases. It diminishes with rising outside temperatures and this can lead to problems to start a fire. When outside temperatures are over 15°C, please check the chimney draught. (for example open the door and keep a burning fire lighter at the entry of the flame channel – flame and flue gases must visibly take off). In case of too little draught first light kindling and add burning wood when the draught has been created.

5 FIREWOOD AND HEATING POWER

The combustion process in our devices has been optimized to enhance their performance and reduce emissions. You can support our efforts to protect our environment by respecting the following recommendations for low-emission heating: Use only dry, natural wood with a residual humidity factor below 20%, or wood briquettes according to DIN EN 17225-3.

Damp, freshly cut or improperly stored wood has a high water content, therefore does not want to burn, makes a lot of smoke and gives not much of heat. Use only firewood which has been stored for at least two years in a dry place with sufficient air circulation. Because dry wood is much more calorific, you can save on fuel costs.

For example: Dry wood has a calorific value of approx. 4 kWh/kg, freshly cut wood only 2 kWh/kg. You will need twice the amount of wood to achieve the same heating power.

	Water content g/kg wood	Calorific value kWh/kg	Consumption raised by %
very dry	100	4.5	0
stored for 2 years	200	4	15
stored for 1 year	350	3	71
freshly cut wood	500	2.1	153



Natural firewood (left) is the best fuel for fireplaces, but you can use also wood briquettes according to DIN 17225-3, Class A1, length >14 cm (5.51 in), diameter >8 cm (3.15 in) (right).



What amount of heat will I get when buying wood per weight?

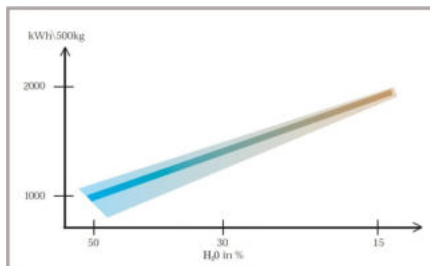

500 kg freshly cut wood	Water content 50%	500 kg x 2.0 kWh/kg = 1000 kWh
500 kg dried wood	Water content 30%	500 kg x 3.3 kWh/kg = 1650 kWh
500 kg dry wood	Water content 15%	500 kg x 4.1 kWh/kg = 2050 kWh

What amount of heat will I get when buying wood per volume (1 cubic meter = 1 m³)?

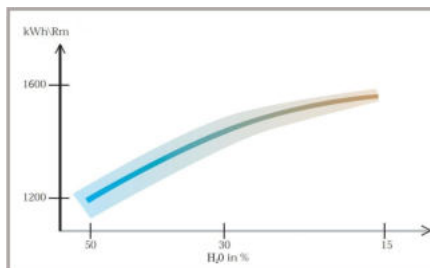

1 m ³ freshly cut wood	Water content 50%	1286 kWh
1 m ³ dried wood	Water content 30%	1518 kWh
1 m ³ dry wood	Water content 15%	1550 kWh

Most suitable for use in open fireplaces are all types of hardwood, like beech or birch. Softwood species (conifers) have a closed-cell structure which is bursting during combustion, causing glowing embers to be thrown out of the fireplace. Hardwood is burning more calm and evenly.

You can control the heat radiation intensity by volume of wood and the intervals for stoking up.

Adjusting the heat by reducing the volume of combustion air is wrong! If there is not enough combustion air available, the energy contained in firewood cannot be completely released. At the same time, the emissions are rising due to unburned particles.

Too much of firewood or inappropriate fuel types can cause overheating and damage.

No kind of waste shall be burned in a fireplace!

Waste on fire = Toxins in your garden!



Never use combustible fluids, like petrol or alcohol to light a fire!

Mind the waste incineration ban!

Remember to use only the recommended fuels described in this User Guide. Unsuitable, not recommended fuels are not allowed to be burned in a fireplace.

6 SEASONING OF FIREWOOD

After cutting the trees, the wood should be seasoned in an open and dry place and protected from rain and snow.

The best time to cut trees is from December till February.

Firewood should be stored under a roof or in a ventilated building (shed). Do not store freshly cut wood in the cellar or in a closed area. It can't dry there.

Our best 3 tips

for heating with wood to become an experience.

1) dry wood

2) dry wood



3) dry wood

7 AMOUNT OF FUEL

Heat output regulation by combustion air reduction is wrong!

By lack of combustion air the calorific capacity of the fuel can't be set free completely. At the same time the emissions increase over the unburned portions.

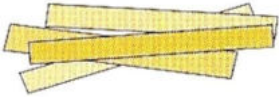
To large amounts of fuel or unsuitable fuel can lead to excessive heating and thus to damage.

Filling weight	Log lenght	Log size
1,5 kg - 2,5 kg	25 cm - 33 cm	20 cm - 30 cm
		

8 OPERATION

The combustion air is three fold:

Primary air (1), secondary air (2), tertiary air (3). Each of these air flows is led across its own inlet and internal distribution channels to its respective place of task. Regulation is done with the air control push rod (4). .

The primary air (1) has as task to steer the degassing speed. The secondary air (2) is necessary additional as preheated air that comes directly on the fuel from above. This air keeps the window clean.

The tertiary air (3) is led directly in the hot gas zone and brings in the oxygen, necessary for a perfect combustion of the gases.

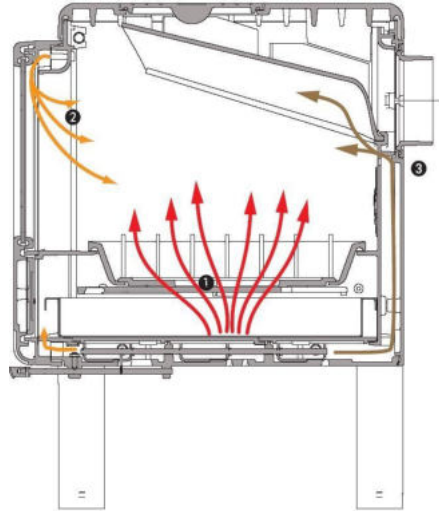





Illustration 4: air flow control

The air control push rod (4) can be put in three different positions. This way the respective air circulations are adapted to the combustion situation.

start-up	nominal heat output	closed
		
<p>Combustion air completely open for a fast start-up</p>	<p>Full heating combustion</p>	<p>Air completely closed</p>

9 HEATING WITH THE IRON DOG

- 1 Control whether the ash pan must be emptied. Minimum distance between ash layer and bottom grate should be 3 cm.
- 2 Bring the push rod in its **“Start-up”** position. The combustion air can flow strongly on the wood in order to reach fast high heating temperatures.
- 3 Pile wood logs loosely on the bottom grate. Put a fire lighter between the logs and light it on. To start the fire, use small wood; large wood logs degas and ignite badly in a cold fireplace.



Never use products as gasoline, white spirits or the like to start a fire!

- 1 Close the fire door and observe the flame development during the first minutes. If the fire goes out, open the door slowly and put a new fire lighter between the wood logs and light it on. Check the chimney draught.
- 2 After approximately 10 minutes, bring the push rod in its “**nominal heat output**” position.
- 3 When the wood has burned down (glow phase) new wood can be added. Bring the push rod in its “**Start-up**” position for about 5 minutes. Then bring it back in its “**nominal heat output**” position.
- 4 If no more wood has to be added, bring the push rod in its “**closed**” position at the end of the combustion, this is when no flames are to be seen any more.



ATTENTION: Never put the air control push rod in the “**closed**” position during the starting up phase or during the nominal heat output phase (lack of air). In case of a sudden oxygen admission (for example when one opens the fire door) gases present in the fire chamber can react with the incoming oxygen (deflagration).

The Iron Dog draws its combustion air from the installation area. Consider the combustion air need in case of simultaneous use of other fire places in the room.

10 ASHES

When burning dry wood and with correct steering of the combustion air, only light and fine ashes remain as a residue.

The ash pan must be emptied regularly.

Ashes in the fire chamber should not rise over the bottom grate frame.

The ashes can easily be pushed into the ash pan beneath. Pull the slide valve and push the ashes downward. The ash pan can be taken out with open fire door.



Empty the ash pan only when the ashes are cold and keep them during at least 24 h in a fire resistant container. Fire risk! In case of fire, call the fire-brigade!

11 CLEANING AND MAINTENANCE

At least once a year at the beginning of a new heating season it should be checked whether fly ash has settled in the smoke pipe and above the baffle plate. Remove the stove top cover or the entire stove top and remove eventual fly ash with an ash cleaner. In order to have a better access to the smoke channels, the baffle plate can be taken out or pushed towards the firing door.

Examine the chimney after longer operational breaks for obstructions.

Some soot on the window can be removed in warm condition with a dry tissue paper. To clean dirtier windows use a wet paper towel, dab it in the ashes and remove deposits on the glass.

Afterwards, wipe with a dry cleansing tissue. Do not use scrubbing tools or aggressive cleaning agents!

The **Iron Dog** should be examined by your specialized enterprise regularly.



Illustration 5: take off the hotplate



Illustration 6: lift the baffle plate

12 HINT

In order to guarantee a secure functioning of the **IRON DOG**, only original spare parts of the manufacturer may be used. Changes in the equipment may be accomplished exclusively through by the manufacturer authorized persons. The **IRON DOG** should be examined by your specialized enterprise regularly.

Non conform use of the equipment leads to expiring of the guarantee! The intended use of the equipment is guaranteed when the guidelines of the User Guide are observed.

13 ERROR SEARCH

Error search

Possible cause	Background	Solution
Draught not available or not sufficient.	Outside temperature higher than indoor temperature, or the chimney cover on the roof is heated by the sun	Control chimney draught Warming-up fire in the chimney Wait until outside temperature is below indoor temperature
Fuel unsuited	Wood logs are too big Wood is damp or wet	Use dry and smaller wood
Combustion air not sufficient	Without sufficient combustion air supply bad igniting and flow	Control push rod position (Start-up position) Control combustion air supply to the installation area Open fire door a little for a short time
	Minimum distance between ash layer in the ash pan and bottom grate too small	Empty the ash pan

Fire burns weakly, much smoke, window becomes black

Possible cause	Background	Solution
Fuel unsuited	Wood logs are too big Wood is damp or wet Fire chamber temperature too low	Only dry wood gives high ignition temperature with desired heat emission.
Combustion air not sufficient	Without sufficient combustion air supply bad igniting and flow.	Control the position of the push rod

Possible cause	Background	Solution
Draught not available or not sufficient	Weather or the situation of the chimney influences the necessary exhaust of the gases.	Check the chimney draught in general In case of important disturbance, change the chimney or install an exhaust gas extractor
	Creosote in or damage to the chimney reduces the necessary draught.	Clean the chimney and the connection pipes and examine them for tightness and damage.
	Check whether other stoves or fireplaces are connected to the chimney.	The chimney draught can be worsened by other connected fireplaces.

14 ATTENTION

We recommend that the **IRON DOG** should be installed and connected by a specialized enterprise, since security and proper functioning of the stove depend on an installation according to the rules. Actual standards and regulations must be observed.

IRON DOG - Partner:

Purchase date:

Ulrich Brunner GmbH

Zellhuber Ring 17-18

D-84307 Eggenfelden

Tel.: +49 (0) 8721/771-0

Fax: +49 (0) 8721/771-100

Email: info@brunner.de

Art.Nr.: 19795



Declaration of Conformity

We:

Ulrich Brunner GmbH
Zellhuber Ring 17-18
D-84307 Eggenfelden

declare that the following products:

Iron Dog 01
Iron Dog 02
Iron Dog 03
Iron Dog 04
Iron Dog 05

to which this declaration relates are in conformity with the following standards:

EN 13240:2005

This EC declaration of conformity becomes invalid if the product is modified or changed without consent.

Eggenfelden 18.5.14

Ulrich Brunner GmbH
Dr.-Ing. Jürgen Vorwerk