

FIREPLACE INSERTS FROM BRUNNER



BKH flat 42-98 green lifting door

State: 2025-02-27



BRUNNER®

Dimension sheets - BKH flat 42-98 green lifting door

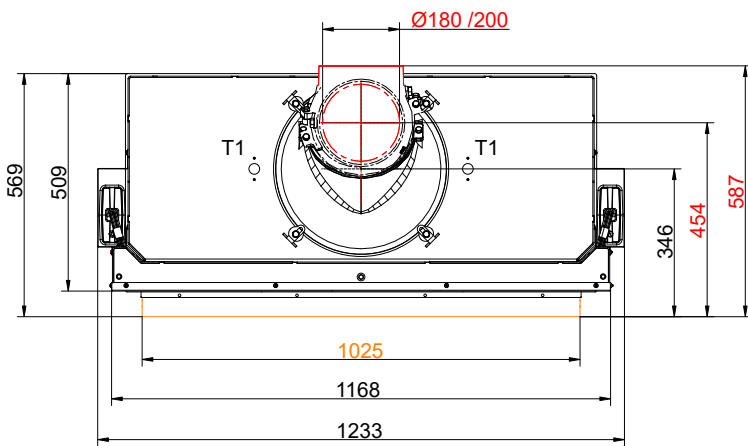
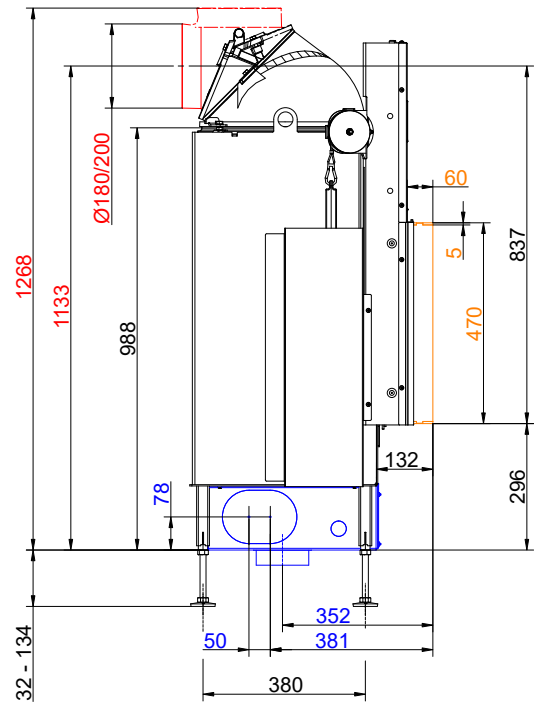
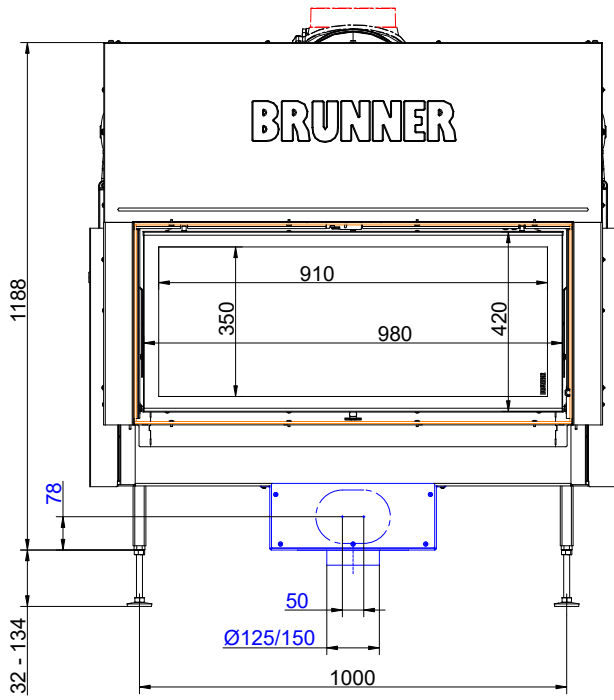

... with mounting frame and Cast iron dome

Dimension sheets - BKH flat 42-98 green lifting door

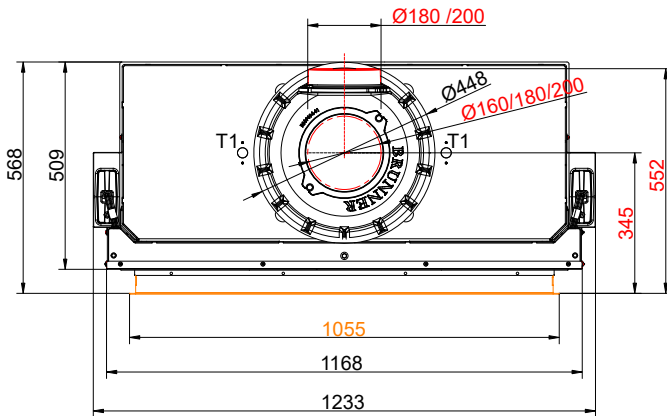
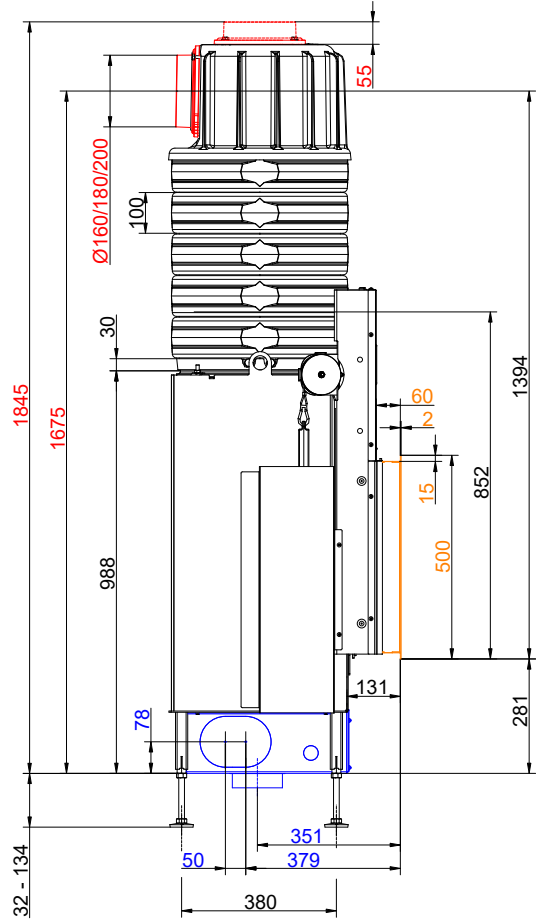
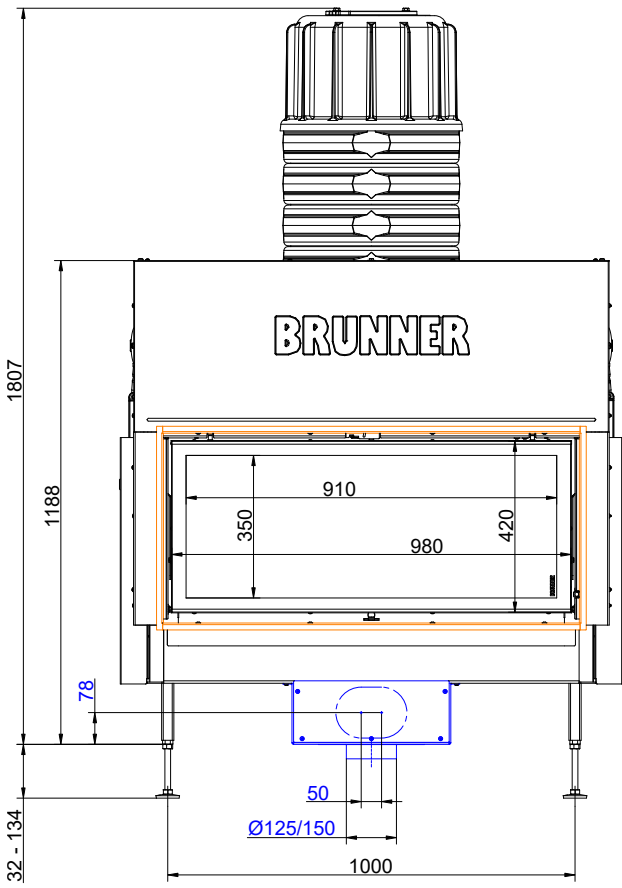

... door frame and MAS

Dimension sheets - BKH flat 42-98 green lifting door

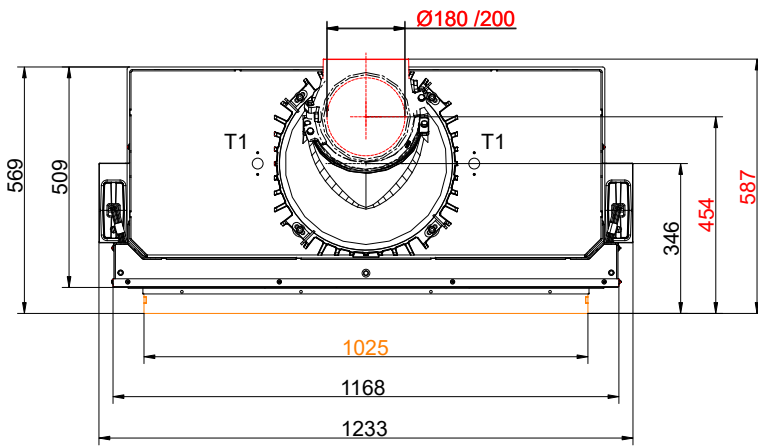
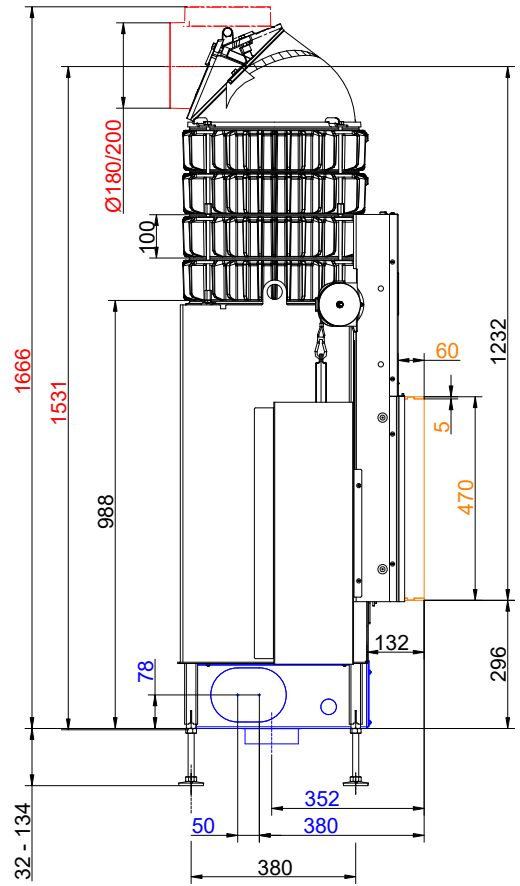
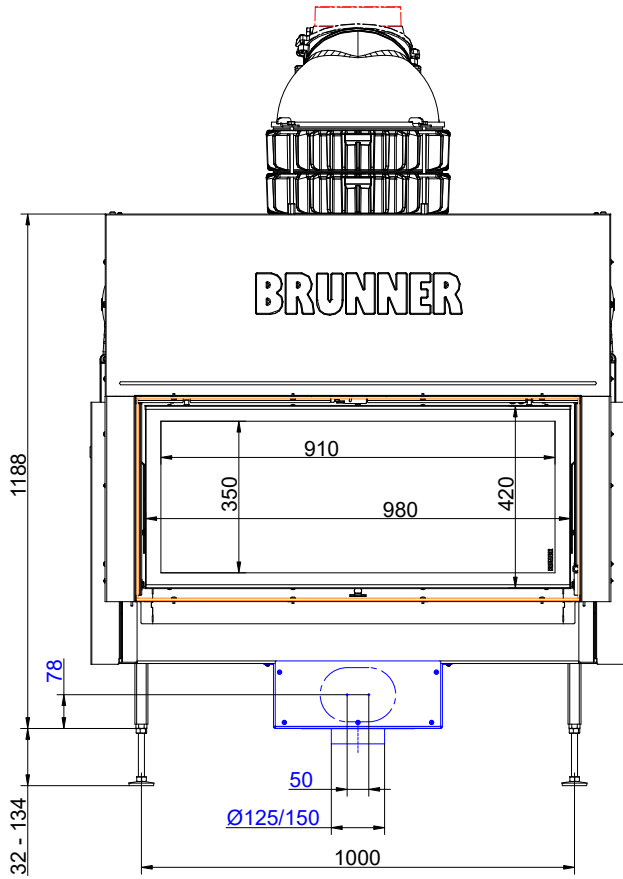

... mounting frame and cast iron heat exchanger rings + dome

Dimension sheets - BKH flat 42-98 green lifting door

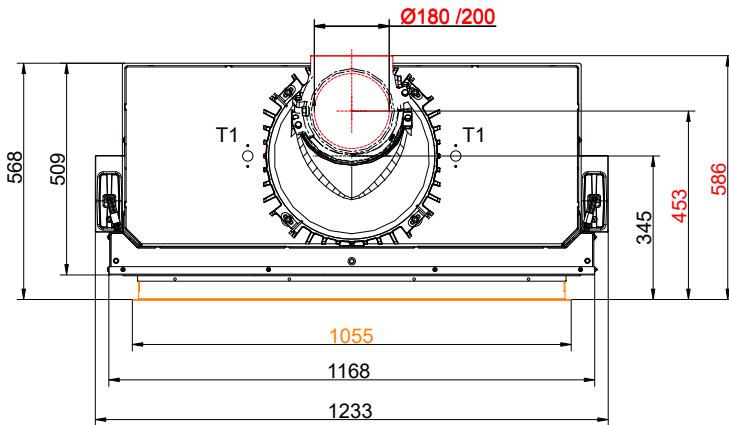
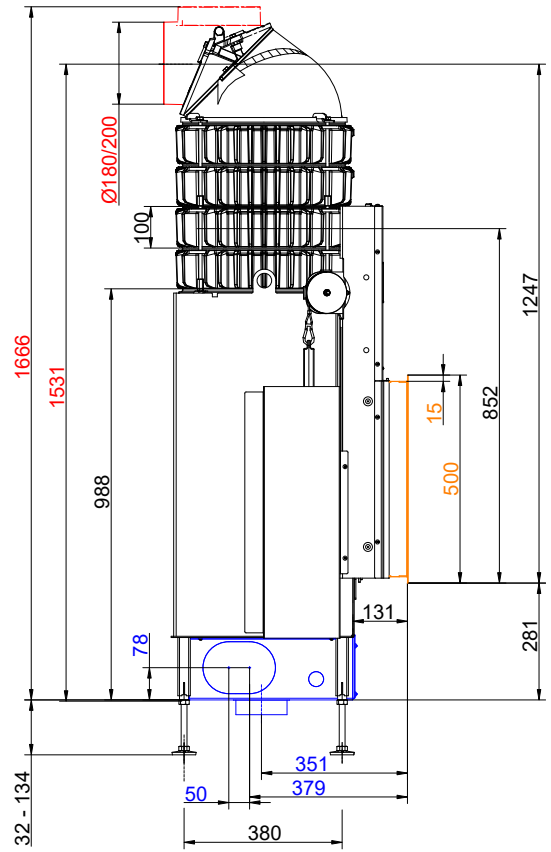
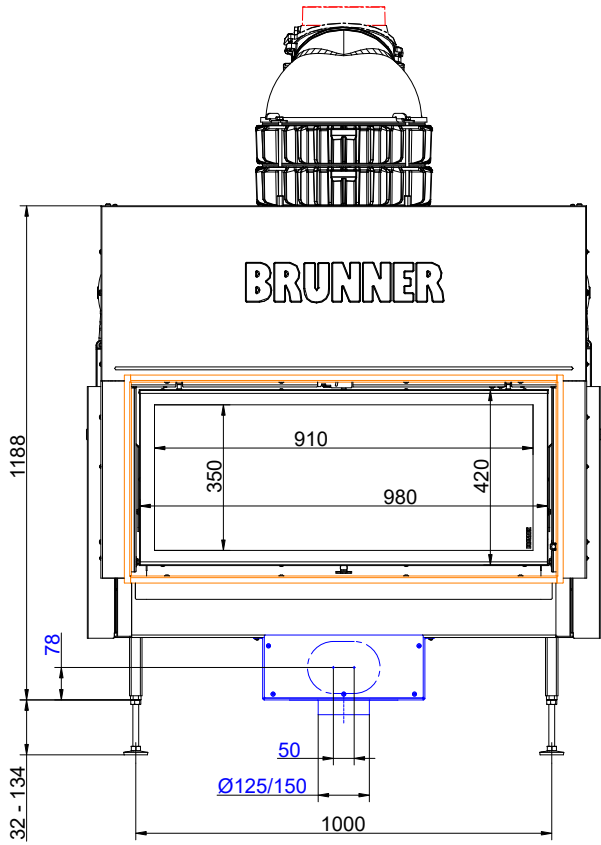

...door frame and cast iron heat exchanger rings + dome

Planning and installation - BKH flat 42-98 green lifting door

Tested according to		EN 13229 W	EN 13229 WA
Values measured at		Rated power ¹⁾	Storage operation ²⁾
Data for functional demonstration			
Rated heat power	kW	11.0	-
Fire wood volume	kg/h	3.3	4.5
Combustion performance	kW	13.0	22
Flue gas mass flow	g/s	13.0	19
Flue gas temperature after:			
Cast iron dome	°C	250	350
4 x cast iron heat exchanger rings + dome	°C	220	260
5 x accumulation rings incl. MAS casted cover ³⁾	°C	-	260
2,0 m ceramic accumulator ⁴⁾	°C	-	180
1,4 m accumulation stones (MSS) ⁴⁾	°C	-	180
Boiler module	°C	208	-
Necessary supply pressure	Pa	12	12
Fuel amount	kg	2.5	5.0
Combustion air consumption	m ³ /h	32	48
Combustion air connection Ø	mm	125	125
Heat distribution			
Insert / reheating surface	%	30 / 30	30 / 30
glass ceramic / glass ceramic coated (GKB)	%	40 / 30	40 / 30
Cross-section of gratings ⁵⁾			
exhaust warm air	cm ²	800	800
Recirculation air	cm ²	800	800
Minimal oven surface for closed construction type			
Heat dissipating surface	m ²	6.8	6.8
Minimal distances of the fireplace			
Heat protection panel for cladding, insulation layer	cm	-	-
to cladding, insulation layer	cm	5	5
to the floor (non-combustible)	cm	3	3
Fire protection with active rear ventilation, intermediate space			
Minimum insulation thickness for construction : insulation material 5 cm rear active ventilation wall ⁶⁾			
for mounting wall (combustible/non-combustible)	cm	5	5
Minimum insulation thickness for construction: insulation material 30 cm closed gap ceiling ⁷⁾			
for ceiling (combustible)	cm	10	10
Fire protection with adequate insulation material			
Minimum insulation thickness for construction: insulation material mounting wall, ceiling, floor ⁷⁾			
with heat protection panel, mounting wall (non-combustible) ⁸⁾	cm	6	6
with heat protection panel, mounting wall (combustible) ⁸⁾	cm	12	12
Mounting wall (non-combustible)	cm	8	8
Mounting wall (combustible)	cm	18	18
Ceiling (non-combustible)	cm	8	8
Ceiling (combustible)	cm	22	22
Floor (non-combustible)	cm	0	0
Minimum distances in front of the combustion chamber, glass ceramic / glass ceramic coated (GKB)			
for combustible parts	cm	≥ 120 / ≥ 80	≥ 120 / ≥ 80

Planning and installation - BKH flat 42-98 green lifting door

Weight

Fireplace insert + combustion chamber inner lining chamotte/cast iron	kg	198 + 109 / 129
--	----	-----------------

Meets requirement/limit values for:

EU / Germany	Ecodesign / 1. BImSchV (Stufe 2)
--------------	----------------------------------

- 1) Indications to "Rated power" determined with 4 heat exchanger rings made of cast iron and Ø200 dome.
- 2) Indications to "Storage operation" for the manual execution of the reheating surface (guide values).
- 3) Damper flap recommended
- 4) Standard value or calculated functional proof required.
- 5) Air cross-sections if the specified nominal heat output is desired as the heat output.
- 6) Fire safety: Values determined with air cross-sections recorded for testing purposes; active rear ventilation, stove shell is heat emitting.
Insulation thickness 5 cm calcium silicate board (brands: Promasil, Silka, Skamol) and 5 cm active rear ventilation with diagonally positioned air circulation and supply air openings of 75 cm² (5x15 cm) each. For detailed design, see assembly instructions.
- 7) Fire safety: values determined in safety test with air cross-sections recorded for testing purposes; stove shell is heat emitting.
Information on replacement insulation material with calcium silicate boards (brands: Promasil, Silka, Skamol).
The specifications for non-combustible walls/ceilings and the structure with a closed gap (30 cm) correspond to the specifications of TROL (Germany), see assembly instructions.
- 8) Heat protection plate: accessory for BKH flat/tunnel/corner versions; factory-fitted for BKH panoramic fireplaces.