

Installation Manual

BKH 5.0 flat
42-42

green

©2025

BRUNNER[®]

INHALT

| | | |
|----------|---|------------|
| 1 | Basic informations..... | 3 |
| 1.1 | Specified symbols..... | 3 |
| 2 | Safety..... | 4 |
| 2.1 | Safety precautions..... | 4 |
| 2.2 | Fire protection..... | 6 |
| 2.2.1 | Mounting wall / Ceiling non-combustible..... | 7 |
| 2.2.2 | Mounting wall / Ceiling combustible (U-value > 0,4 W/m ² K)..... | 8 |
| 2.2.3 | Mounting wall / Ceiling combustible (U-value < 0,4 W/m ² K)..... | 11 |
| 3 | Delivery contents BKH 42-42 flat..... | 12 |
| 3.1 | Heat protection panel (optional)..... | 14 |
| 3.2 | Catalytic converter (optional)..... | 14 |
| 3.3 | Air connection box (optional)..... | 15 |
| 4 | Installation..... | 16 |
| 4.1 | Instructions BKH accessories & additional options..... | 16 |
| 4.2 | Setting up..... | 19 |
| 4.2.1 | Remove the transport locks..... | 19 |
| 4.2.2 | Set up the fireplace..... | 20 |
| 4.2.3 | Heat protection panel (optional)..... | 21 |
| 4.2.4 | Variant with external combustion air connection..... | 32 |
| 4.3 | Fitting: catalytic converter..... | 47 |
| 4.4 | Fitting: deflection - combustion chamber..... | 51 |
| 4.5 | Variants Combustion chamber lining..... | 59 |
| 4.5.1 | Chamotte inner lining..... | 59 |
| 4.6 | Variants heat exchanger..... | 61 |
| 4.6.1 | Connection with catalytic converter..... | 61 |
| 4.6.2 | Connection without catalytic converter..... | 62 |
| 4.6.3 | Cast iron dome..... | 68 |
| 4.6.4 | MAS..... | 78 |
| 4.7 | Variant: EOS..... | 85 |
| 4.7.1 | Bottom cover air box EOS..... | 85 |
| 4.7.2 | Thermocouple..... | 89 |
| 4.7.3 | Door contact switch..... | 92 |
| 5 | Frame variants..... | 95 |
| 5.1 | Door frame (BKH with side-opening door)..... | 95 |
| 6 | Conversions, settings..... | 97 |
| 6.1 | Change of the door stop..... | 97 |
| 6.2 | Adjusting of self-closing door..... | 113 |
| 6.3 | Modification - lifting door: "non self closing"..... | 120 |
| 7 | Disposal..... | 123 |
| 8 | Technical data..... | 124 |

1 BASIC INFORMATIONS



All instructions delivered with products must be observed. We do not accept any warranty claim or liability for damage resulting from failure to observe these installation instructions!
Improper installation can cause injury and material damage!

The floor space of the room must have a suitable structure and sufficient dimensions to ensure proper functioning of the fireplace.

Please note that other installation and assembly instructions are included in other packaging units!

Dimensioning of downstream heat accumulator must be according to valid stove-setting rules.

During installation of the fireplace, all dimensions and minimal clearances of the fireplace casing must be held as specified by the manufacturer.

All binding national or EU standards and local regulations for the installation of fireplaces must be observed.

All valid stove fitting rules and regulations of local construction law must be observed and followed.

Please follow the relevant regulations of your country.

When these instructions are followed and all works are done properly, this will ensure a safe, energy-saving and environmentally friendly operation of the stove. Pictures shown are not to be considered as complete representations of any kind.

Subject to technical and assortment changes.

Please notify your supplier of any damage which might have occurred during transport.

Please keep these instructions.

Please also take note of the online product documentation provided by:



[General instructions of the Brunner products installation for the stove construction.](https://www.brunner.de/produktdownloads/kachelofen-kamine/allgemeine-hinweise-fuer-den-aufbau_de.pdf)

(https://www.brunner.de/produktdownloads/kachelofen-kamine/allgemeine-hinweise-fuer-den-aufbau_de.pdf) laden können.



1.1 SPECIFIED SYMBOLS

In this documentation, a distinction is made between:

Operating personnel as the **User of the system**, i.e. the end user, which has received instructions from the Contractor and does not necessarily have additional qualifications.

Operating personnel as the **Contractor**, i.e. the qualified professionals, which are entitled to perform the indicated specialist works.

In this document, the following symbols are used:

**DANGER**

A danger of high risk persists, which leads to severe injury or death, if this endangering situation is not avoided.

WARNING

A danger of medium risk persists, which can lead to severe injury or death, if this endangering situation is not avoided.

CAUTION

A danger of low risk persists, which can lead to minor or moderate injury, if this endangering situation is not avoided.

**ATTENTION**

There is a certain risk, which can lead to a malfunction or damage of the related system and all devices connected with it, if the indicated notifications are not followed.

**NOTE**

Additional helpful information

2 SAFETY

2.1 SAFETY PRECAUTIONS

Fireplaces may be set up only in rooms or areas with no risk of danger due to their location, structure or intended use.

Working on the stove

Installation, commissioning, servicing and maintenance works on the product may be carried out only by an authorized stove-fitter. Safety and efficiency of the system depend on this!

Working with electronics

Switch off the emergency switch or circuit breaker, and secure them against switching on again.



Fireplaces with external air supply are not independent from room air supply and must be considered and designed as roomsealed fireplaces. In connection with a ventilation or extraction system, we recommend the use of a negative pressure safety device (Art.No.: 11600.1).

Installation must be carried out by an authorized stove-fitter, because safety and efficiency of the system depend mostly on proper installation of the product. All valid stove fitting rules and regulations of building law must be observed and followed. Make sure to instruct the owner or user about the functions and controls of the system and possibly installed safety devices.

Fireplaces must be built to ensure safe operation and fire safety in order to eliminate possible risks and unacceptable loads. They have to be ready for use over an adequate period of time.

Make sure to instruct the owner or user about the functions and controls of the system and possibly installed safety devices.

Remember to use only genuine replacement parts.

2.2 FIRE PROTECTION

The thermal insulation listed in the fire protection information is implemented with substitute insulation material in the form of calcium silicate boards (e.g. brands: Promasil, Silka, Skamol).

If a different insulating material is used (e.g. vermiculite), the manufacturer's specifications must be used for conversion to the installed insulating material.

The thermal insulation for non-combustible add-on walls and ceilings is based on the requirements of TROL (Germany).

For extension walls made of combustible building materials, fire protection can also be provided in a version with active rear ventilation. This variant has been tested and is created with an insulation thickness of 5 cm. It is important to ensure that air flows across the entire width and height.







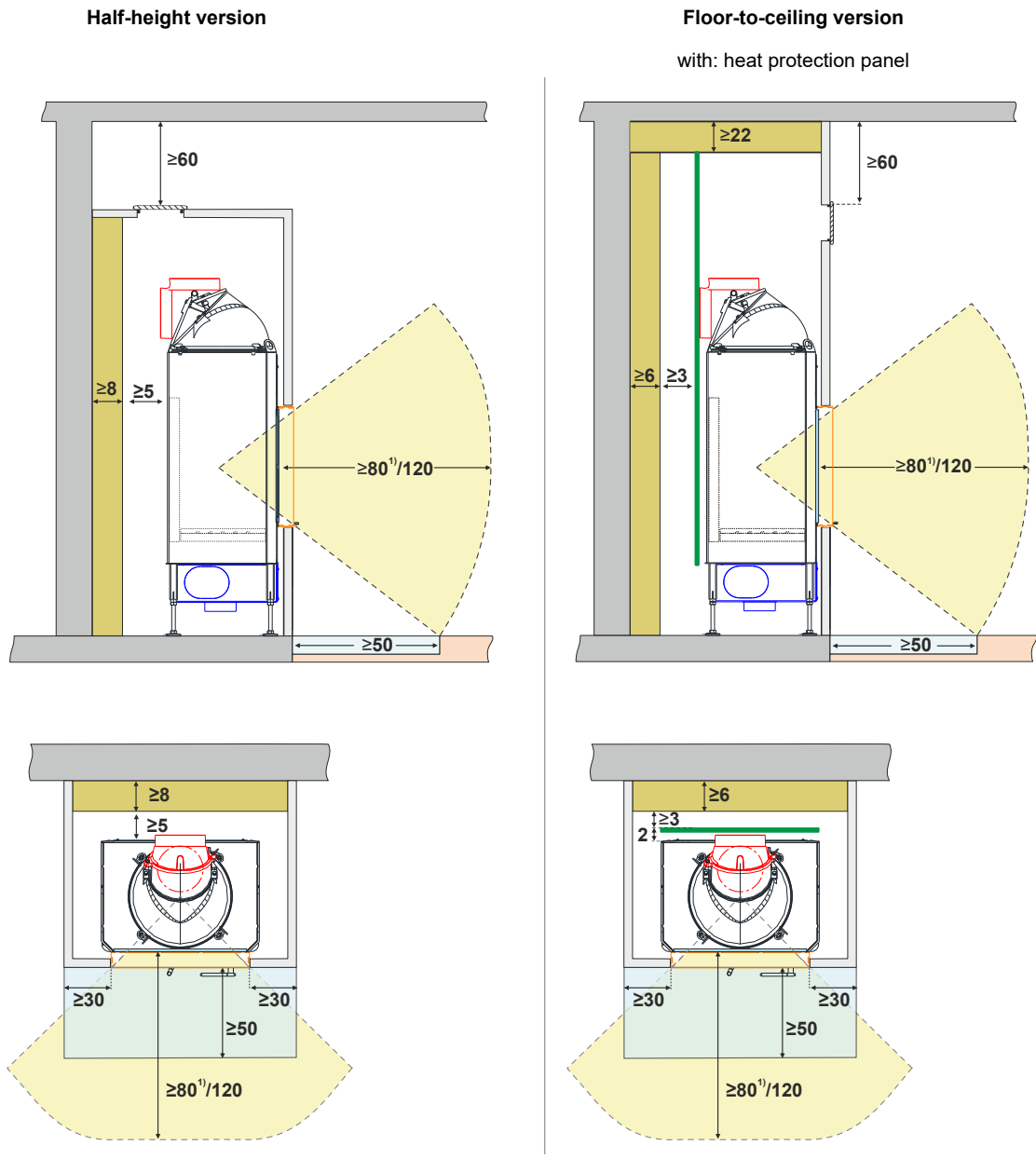

The room air must be able to flow in at the bottom and out at the top. The air inlet and outlet openings (cross-section 75 cm²) must not be sealable. In normal operation, the temperatures at the air outlet are below 85°C.

For thermally insulated add-on walls with a U-value < 0.4 W/m²K, the fire protection must be designed with active rear ventilation.

2.2.1 MOUNTING WALL / CEILING NON-COMBUSTIBLE

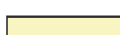
Structure: Substitute insulation material | Mounting wall / Ceiling non-combustible



- | | | | | | |
|---|---|---|--|---|--|
|  | floor/wall/ceiling non-combustible |  | fireplace cladding |  | wall/ceiling/floor/attachments combustible/to be protected |
|  | convection opening (fireplace cladding) |  | substitute insulation material calcium silicate |  | radiation range |
|  | heat protection panel |  | non-combustible flooring / floor protection pane |  | convection opening (active rear ventilation) |

¹⁾ Glass ceramic coated (GKB)
 All figures in cm
 When designing the exhaust system and exhaust pipe, national standards and fire protection regulations must be observed

2.2.2 MOUNTING WALL / CEILING COMBUSTIBLE (U-VALUE > 0,4 W/M²K)

Structure: Substitute insulation material | Mounting wall / Ceiling combustible

Half-height version



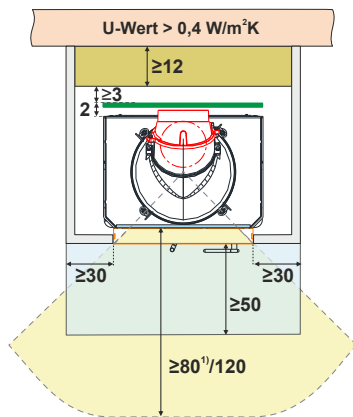
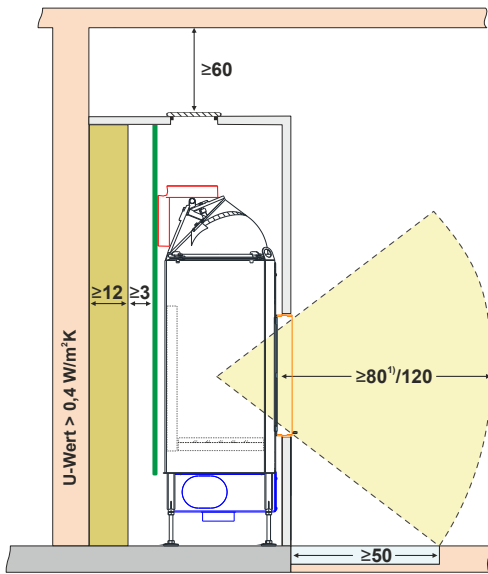



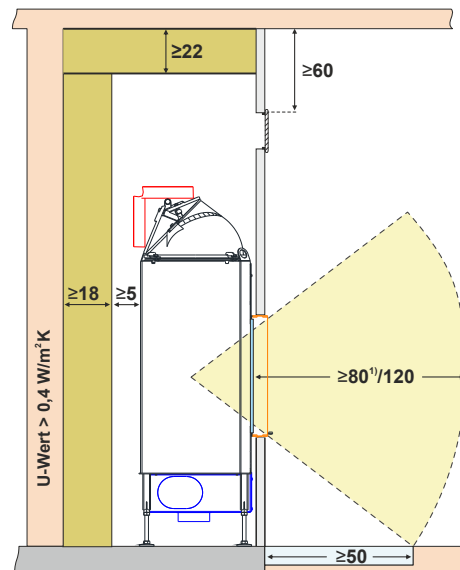
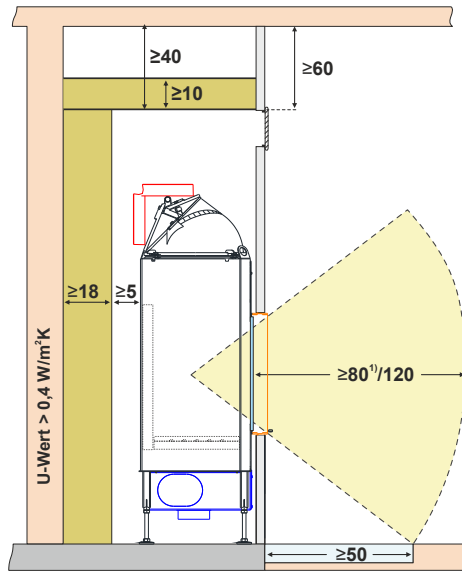

with: heat protection panel
U-value Mounting wall > 0,4 W/m²K

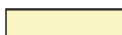

Floor-to-ceiling version

without: heat protection panel
U-value Mounting wall > 0,4 W/m²K



- | | | |
|---|--|--|
|  floor/wall/ceiling non-combustible |  fireplace cladding |  wall/ceiling/floor/attachments combustible/to be protected |
|  convection opening (fireplace cladding) |  substitute insulation material calcium silicate |  radiation range |
|  heat protection panel |  non-combustible flooring / floor protection pane |  convection opening (active rear ventilation) |

¹⁾ Glass ceramic coated (GKB)

All figures in cm

When designing the exhaust system and exhaust pipe, national standards and fire protection regulations must be observed

Structure: Substitute insulation material | active rear ventilation | Mounting wall/ Ceiling combustible

Half-height version

with: active rear ventilation
U-value Mounting wall > 0,4 W/m²K

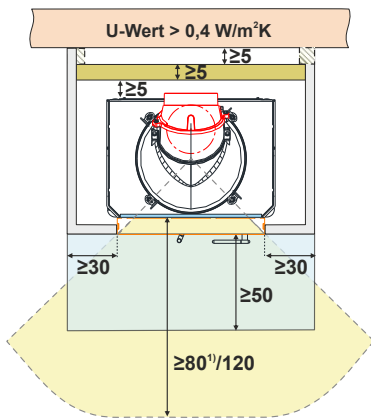
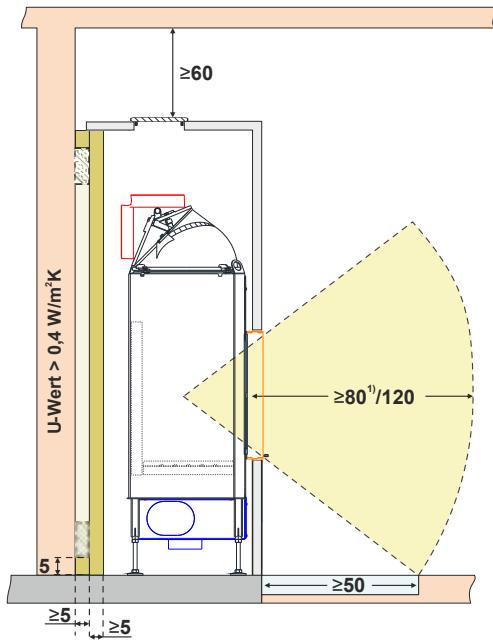

Detail:

active rear ventilation (2x75 cm²)

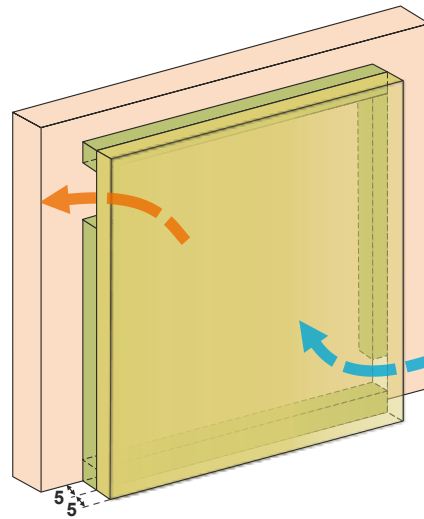
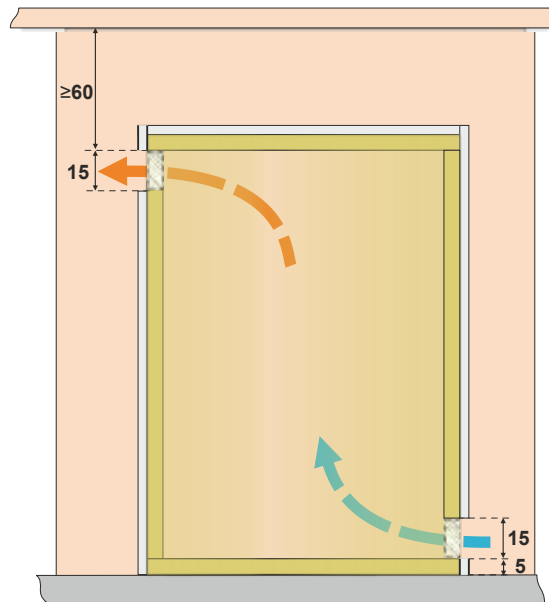

floor/wall/ceiling
non-combustible

convection opening (fire-
place cladding)

heat protection panel

fireplace cladding

substitute insulation material
calcium silicate

non-combustible flooring /
floor protection pane

wall/ceiling/floor/attach-
ments combustible/to be
protected

radiation range

convection opening (active
rear ventilation)

¹) Glass ceramic coated (GKB)

All figures in cm

When designing the exhaust system and exhaust pipe, national standards and fire protection regulations must be observed

Structure: Substitute insulation material I aktive Hinterlüftung I Mounting wall/ Ceiling combustible

Floor-to-ceiling version



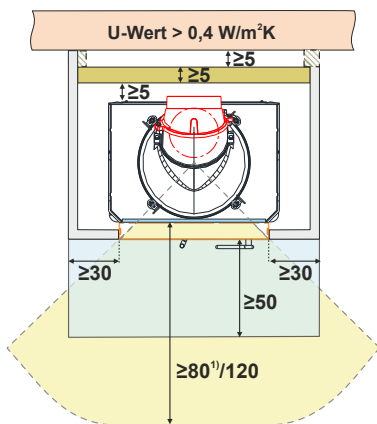
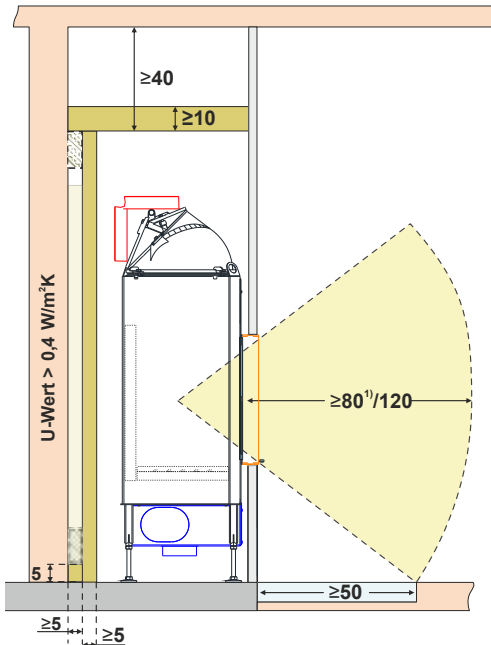



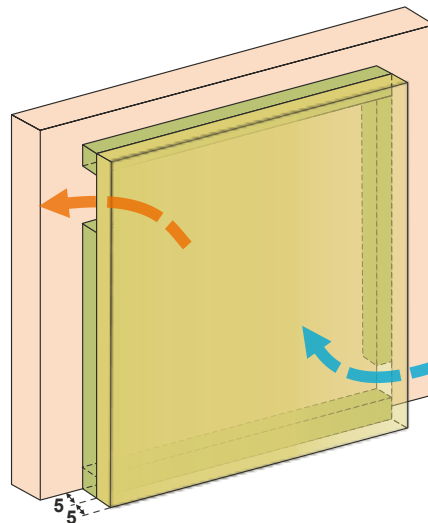
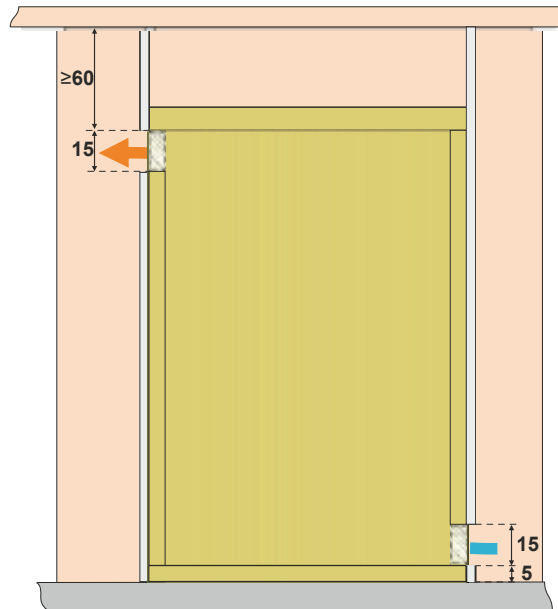

with: active rear ventilation
U-value Mounting wall > 0,4 W/m²K

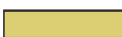
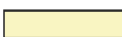

Detail:

active rear ventilation (2x75 cm²)



- | | | |
|---|--|--|
|  floor/wall/ceiling non-combustible |  fireplace cladding |  wall/ceiling/floor/attachments combustible/to be protected |
|  convection opening (fireplace cladding) |  substitute insulation material calcium silicate |  radiation range |
|  heat protection panel |  non-combustible flooring / floor protection pane |  convection opening (active rear ventilation) |

¹⁾ Glass ceramic coated (GKB)

All figures in cm

When designing the exhaust system and exhaust pipe, national standards and fire protection regulations must be observed

3 DELIVERY CONTENTS BKH 42-42 FLAT

with side-opening door (DT)

BKH 42-42 flat with side-opening door (DT)

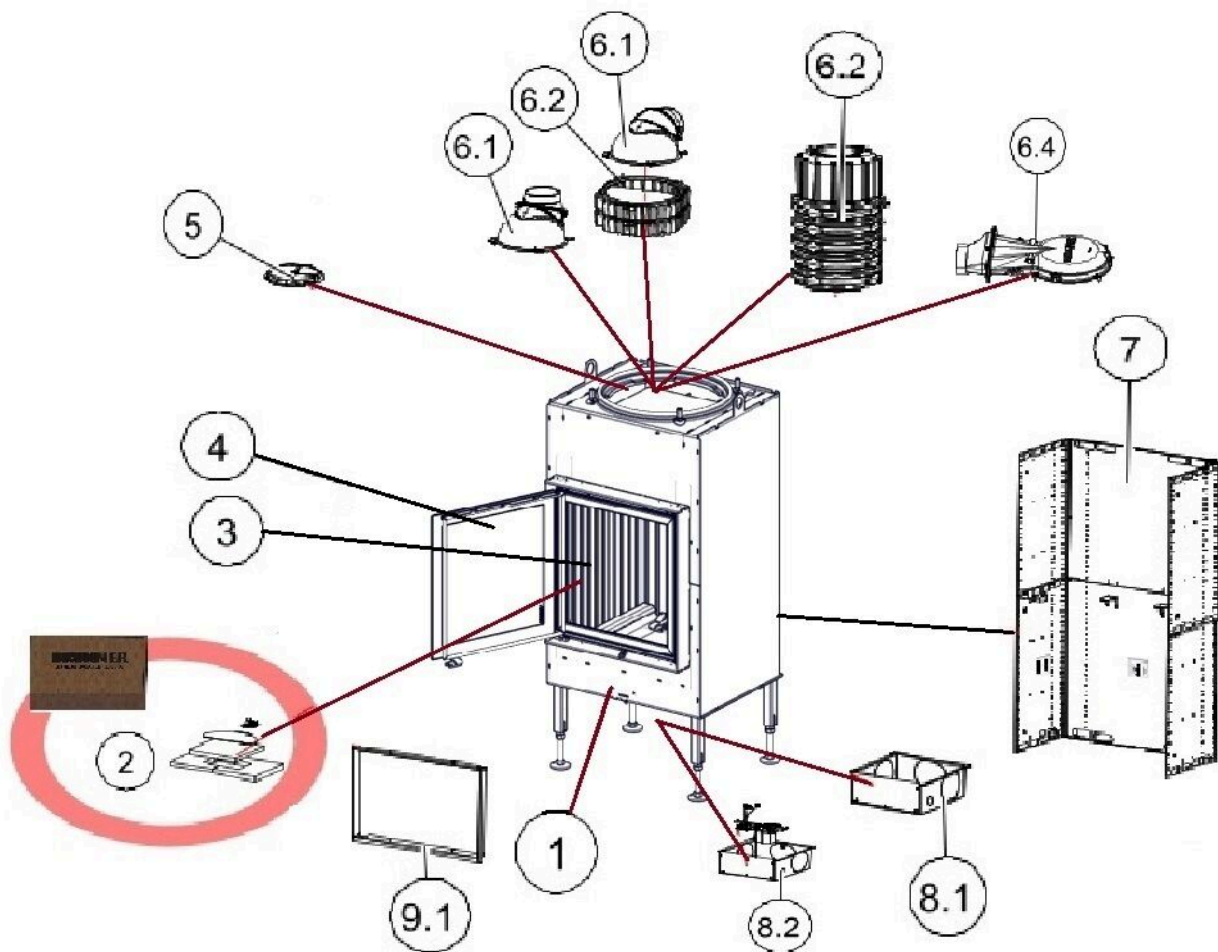

| Pos. | Designation |
|---------------------|---|
| 1 | BKH - variants: |
| | BKH 5.0 flat 42-42 DT with manual operation, with Ceramic glass (GK) Chamotte inner lining set (FR) |
| | BKH 5.0 flat 42-42 DT with manual operation, with Glass ceramic coated (GKB) Chamotte inner lining set (FR) |
| | BKH 5.0 flat 42-42 DT for EAS/EOS with Ceramic glass (GK) Chamotte inner lining set (FR) |
| | BKH 5.0 flat 42-42 DT for EAS/EOS with Glass ceramic coated (GKB) Chamotte inner lining set (FR) |
| | BKH 5.0 flat 42-42 DT with manual operation, with Ceramic glass (GK) Combustion chamber inner lining cast iron (FR/Guss) |
| | BKH 5.0 flat 42-42 DT with manual operation, with Glass ceramic coated (GKB) Combustion chamber inner lining cast iron (FR/Guss) |
| | BKH 5.0 flat 42-42 DT for EAS/EOS with Ceramic glass (GK) Combustion chamber inner lining cast iron (FR/Guss) |
| | BKH 5.0 flat 42-42 DT for EAS/EOS with Glass ceramic coated (GKB) Combustion chamber inner lining cast iron (FR/Guss) |
| 2 | The non-installed parts (e.g. deflection plates, control levers, etc.) and any accessories ordered (e.g. catalytic converter, packaging with EOS, etc.), including the instructions box, are packed in the combustion chamber |
| 3 | verbaute Combustion chamber lining: |
| | - aus Chamotte |
| | - aus Cast iron |
| 4 | Ceramic glass (GK) |
| 5 | Catalyst module BKH 5.0 |
| Smoke hood variants | |
| 6.1 | Rotating cast iron dome with adjustable connecting piece \varnothing 180 mm |
| | Rotating cast iron dome with connecting piece d=200 mm |
| 6.2 | with heat exchanger rings |
| 6.3 | Connection variant MAS SET440 |
| 6.4 | Cast iron dome low |
| Additional options | |
| 7 | Heat protection panel |
| 8.1 | Supply air connection box \varnothing 125 mm |
| | Supply air connection box \varnothing 150 mm |
| 8.2 | Supply air connection box \varnothing 125 mm with EOS / EAS |
| 9.1 | Door frame, black |
| 9.2 | Mounting frame, black |

3.1 HEAT PROTECTION PANEL (OPTIONAL)

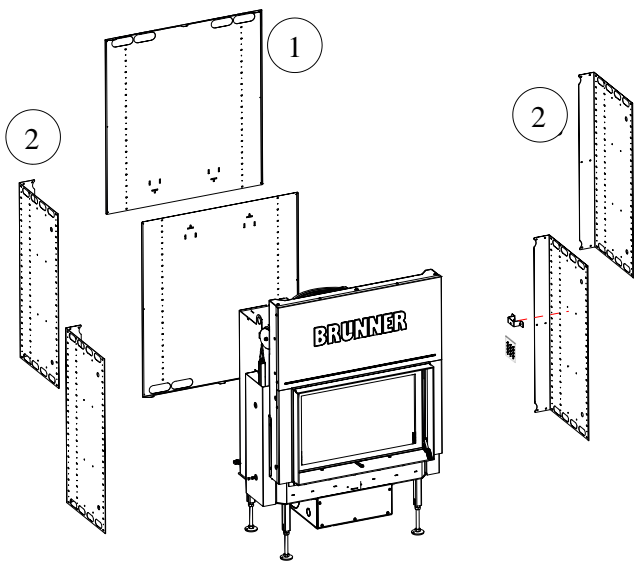

| | |
|---|---|
| 1 | Heat protection panel backwall, incl. screws |
| 2 | Heat protection panel, side, incl. mounting frame, screws |

3.2 CATALYTIC CONVERTER (OPTIONAL)



The catalytic converters are coated with a catalytically active layer. This coating can consist of mixed metal oxides or also of precious metals. In order not to limit the effect of this catalytically active layer, the catalysts may only be handled with gloves, preferably with disposable gloves.



In order not to limit the effect of this catalytically active layer, the catalysts may only be handled with gloves, preferably with disposable gloves.



ATTENTION

The catalysts are fragile and must only be handled with care. Avoid bumping and do not drop the catalytic converter. This could destroy the catalytic converter!

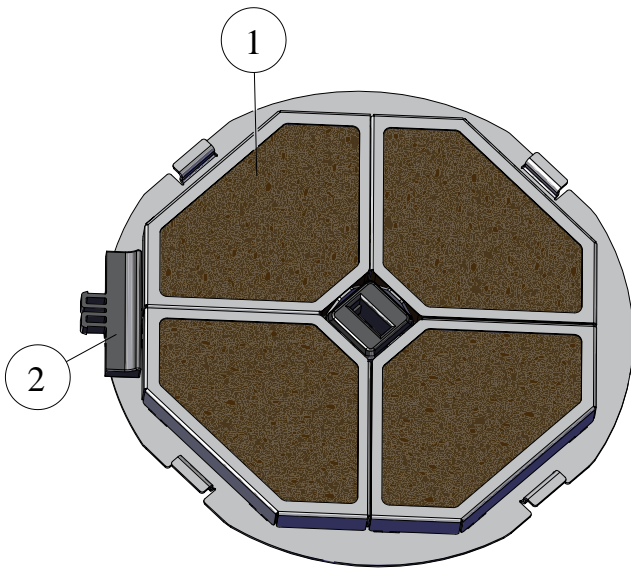

| | |
|---|---------------------|
| 1 | catalytic converter |
| 2 | assembly tool |



Note

This catalytic converter is suitable for all BKH units (with lifting door, with side opening door, tunnel, with cast dome, with heat exchanger cast rings and MAS).

This catalytic converter can also be retrofitted.

3.3 AIR CONNECTION BOX (OPTIONAL)

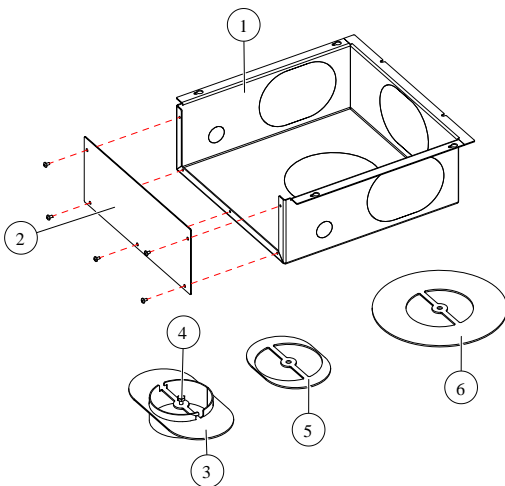

| Pos. | Description of use |
|------|---|
| 1 | Air connection box - allows the connection of an external combustion line |
| 2 | Cover for air connection box |
| 3 | Air connection is welded, connection point for combustion air line |
| 4 | Screw for fixing the respective clamping plate |
| 5* | Clamping plate for fixing the external combustion air line on the side |
| 6* | Floor clamping plate for fixing the external combustion air line to the floor |

*both clamp plates are supplied, but only the appropriate one is used.

i The perforation of the cut-outs for the connection piece can optionally be masked with aluminum adhesive tape.

4 INSTALLATION

4.1 INSTRUCTIONS BKH ACCESSORIES & ADDITIONAL OPTIONS

The instructions for installing the respective accessories and additional options are available via the following QR codes.

Heat exchanger rings

for:



BKH flat
BKH corner
BKH Tunnel

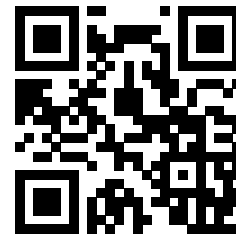

<https://www.brunner.de/21776>

Connection pipe eccentric

for:



BKH flat
BKH corner
BKH Tunnel

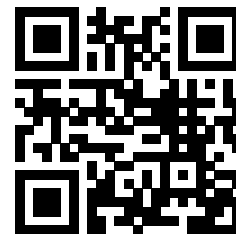

<https://www.brunner.de/21788>

Cast iron dome ø 180 mm low**for:**

BKH flat 42-42
BKH flat 42-50
BKH flat 42-66
BKH Tunnel 42-50
BKH Tunnel 42-66
BKH corner 42-42-42
BKH corner 42-66-42
(DTL & DTR)

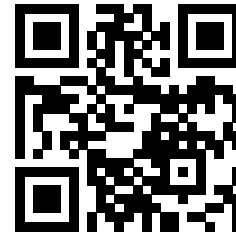

<https://www.brunner.de/23590>

Modular Accumulator MAS**for:**

BKH flat
BKH corner
BKH Tunnel
BKH Panorama

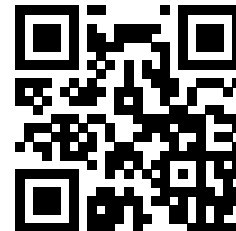

<https://www.brunner.de/22266>

Boiler module**for:**

BKH flat
BKH corner
BKH Tunnel

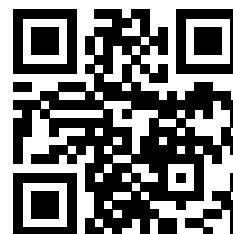

<https://www.brunner.de/23299>

for:**Integrated secondary air device**

BKH flat
BKH corner
BKH Tunnel

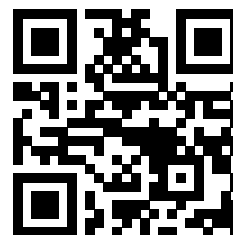

<https://www.brunner.de/23423>

4.2 SETTING UP

**DANGER**

Possible personal injury and/or property damage caused by improper installation

Assembly and installation of BKH requires extensive specialist knowledge.

- Assembly and installation works must be performed by authorized professionals.

**Danger**

Risk of injury caused by heavy loads

Carrying of heavy loads can lead to injuries.

- The equipment should be carried by at least two people.
- Use appropriate carrying aids.
- Keep the transport weight in mind.

As long as the device is on the wooden pallet, it can be transported with a hand truck or forklift as usual.

4.2.1 REMOVE THE TRANSPORT LOCKS

Version with side-opening door 



NO TRANSPORT LOCK !



4.2.2 SET UP THE FIREPLACE

Summarised information:

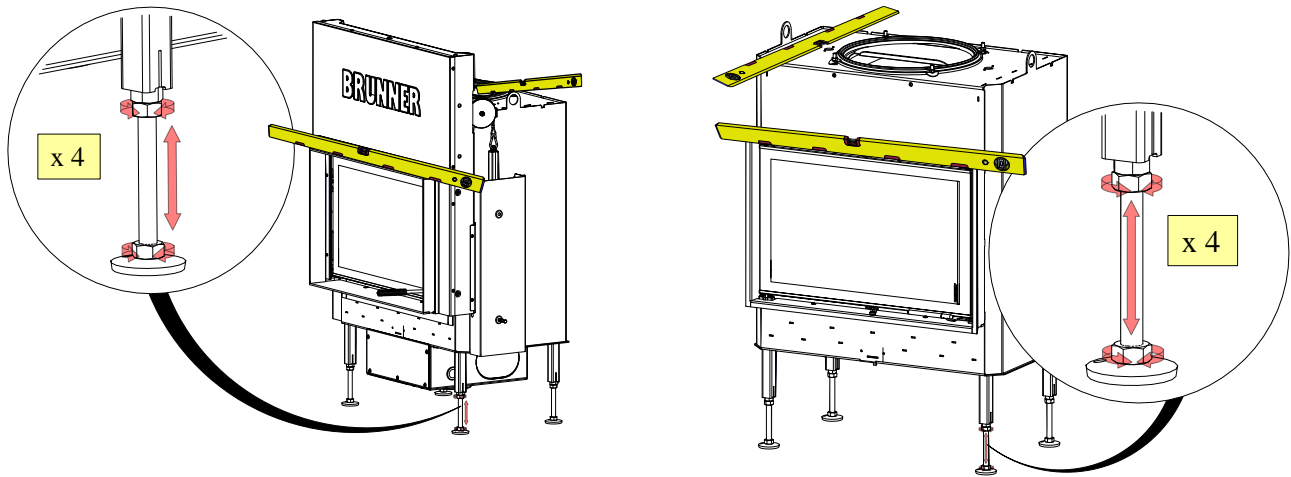

Version without outside air connection



Workflow:

1

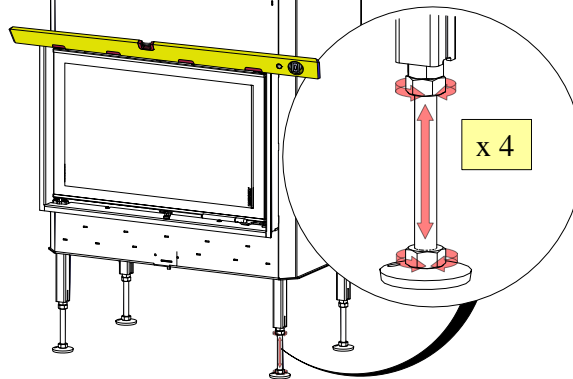

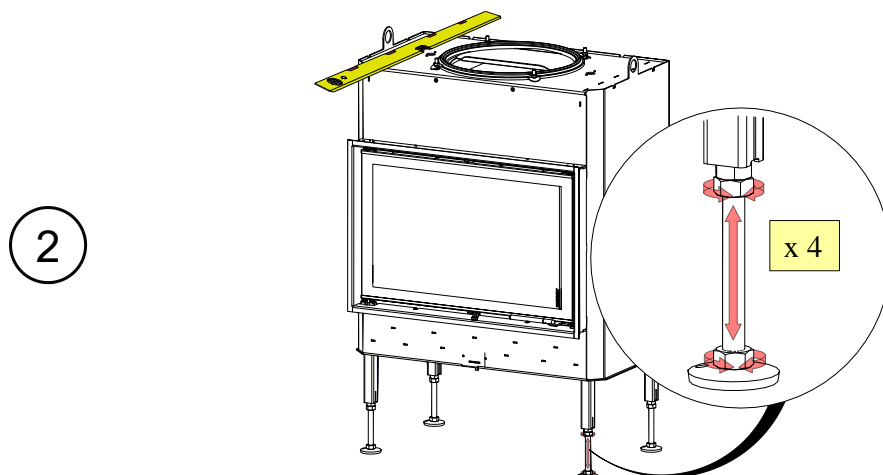

4.2.3 HEAT PROTECTION PANEL (OPTIONAL)



Hint

If you use heat protection panels, they should be mounted before positioning the fireplace insert. First mount the heat protection panels, then place the fireplace insert against the wall.

Installation of the variant with all heat protection panels



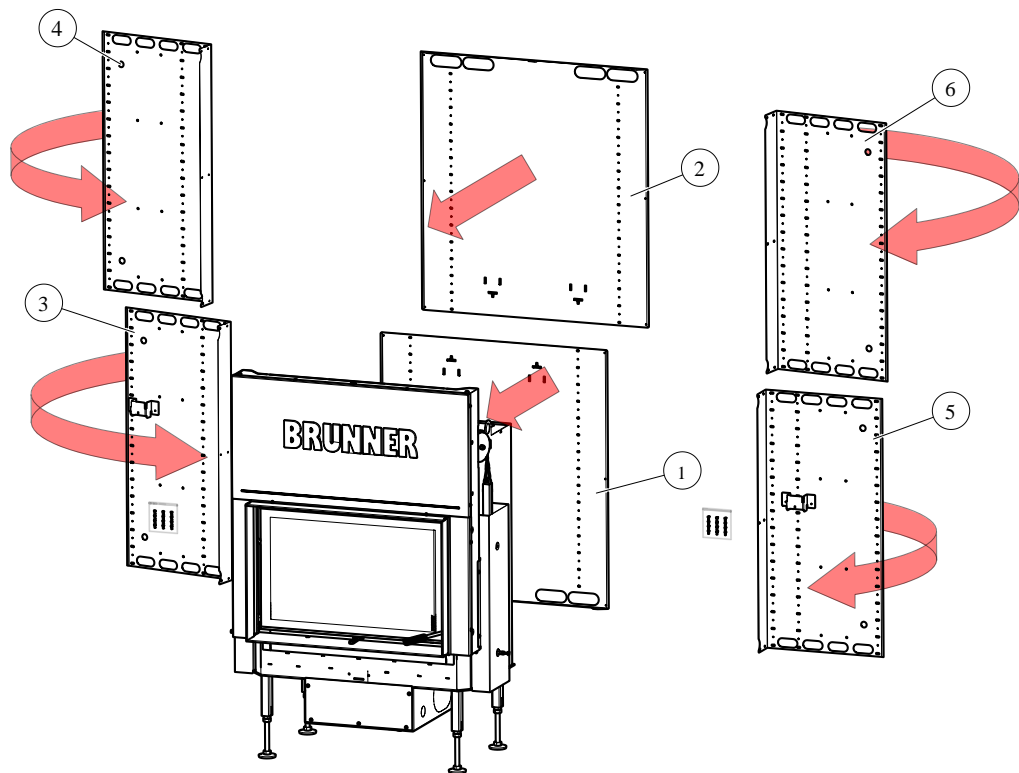

Im. 1: Summarised information



CAUTION
Risk of injury from sharp edges!
Wear protective gloves!!



Variant A:

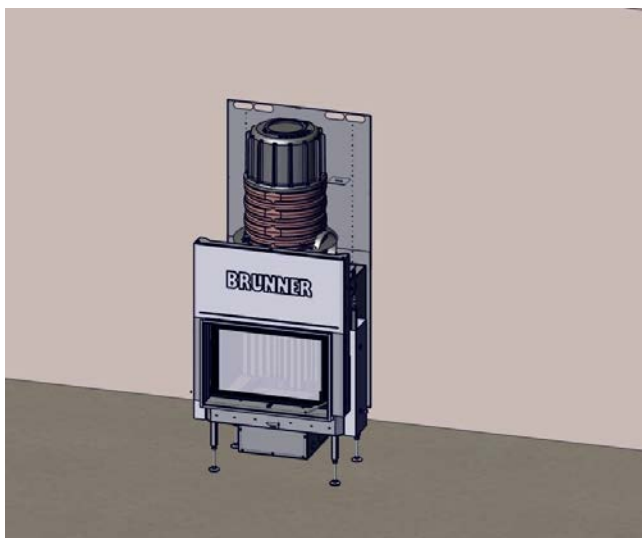

Required are:
Art.Nr.HK004450

Assembly steps:
1 - 2

Variant **B**:

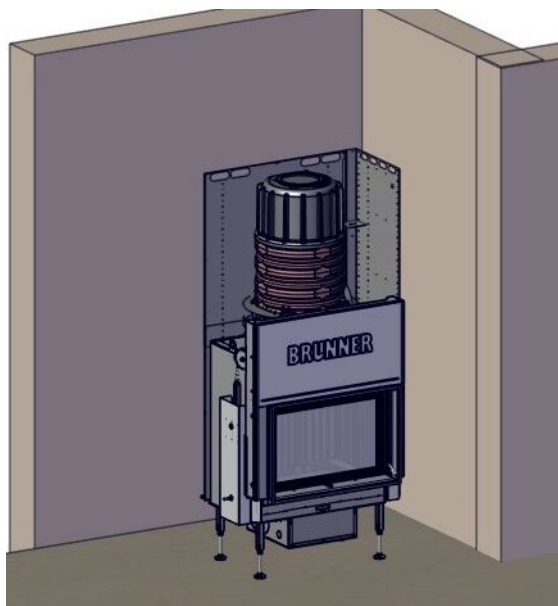

Required are:
Art.Nr.HK004450-01

Assembly steps:
1 - 5 - 2 - 6

Variant **C**:

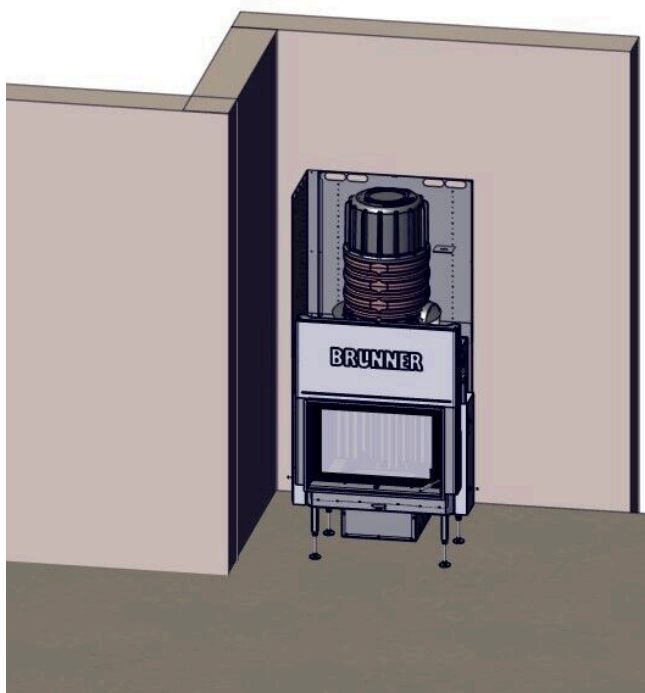

Required are:
Art.Nr.HK004450-01

Assembly steps:
1 - 3 - 2 - 4

Variant **D**:

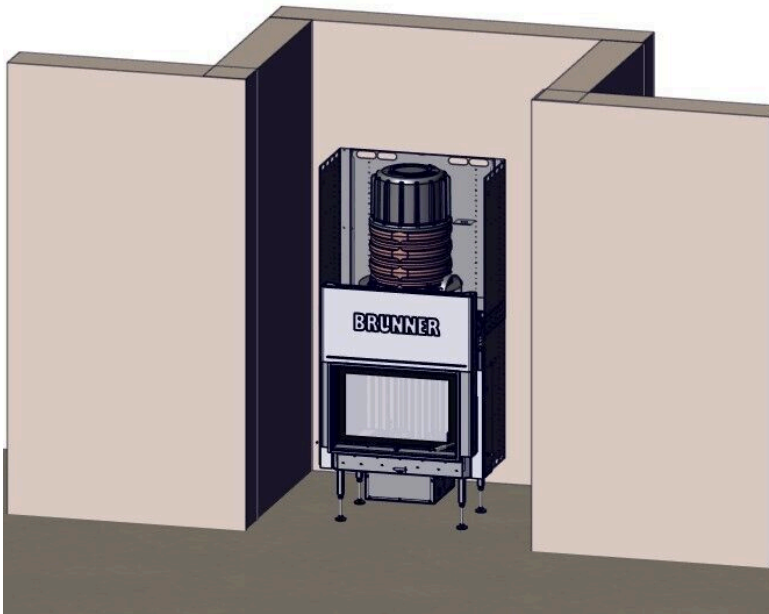

Required are:
Art.Nr.HK004450-02

Assembly steps:
1 - 3 - 5 - 2 - 4 - 6

Mounting: heat protection panel (ST)



INFO

Assembly for complete set-up with heat protection panels. Depending on planning/needs, only carry out the specific work steps.

Workflow:

1

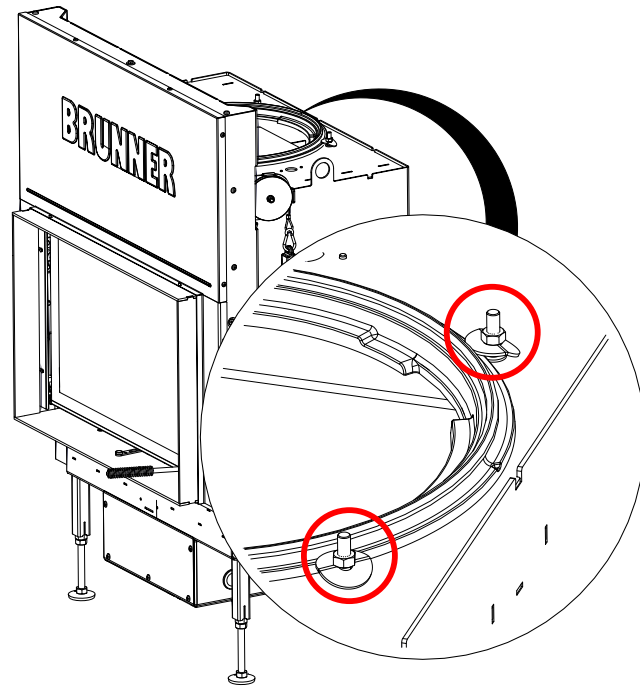

2

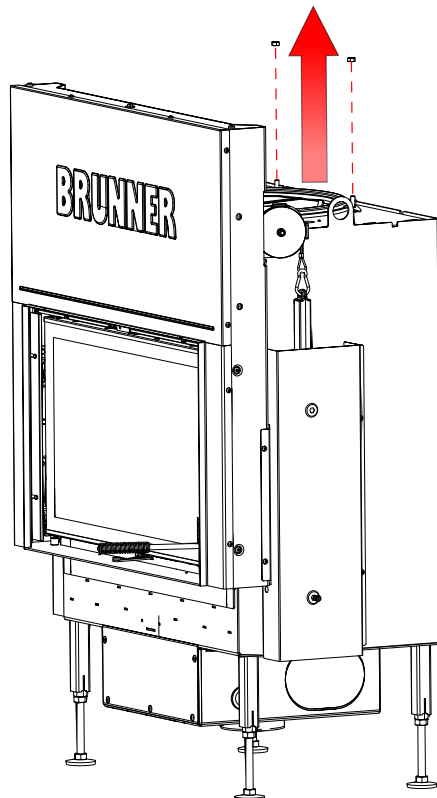

3

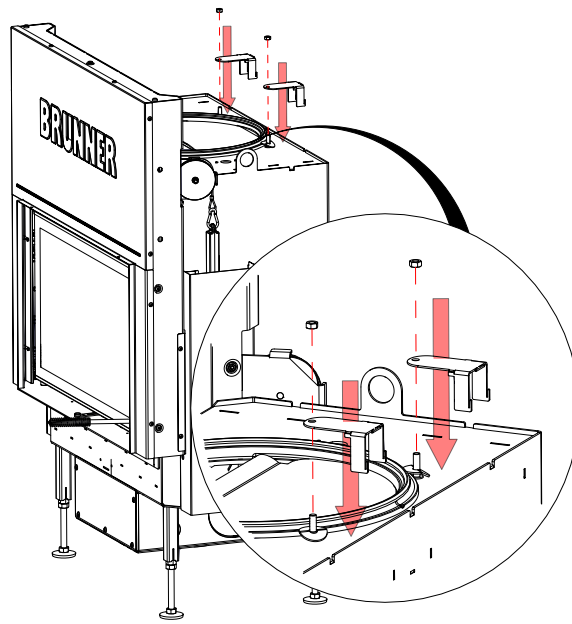

4

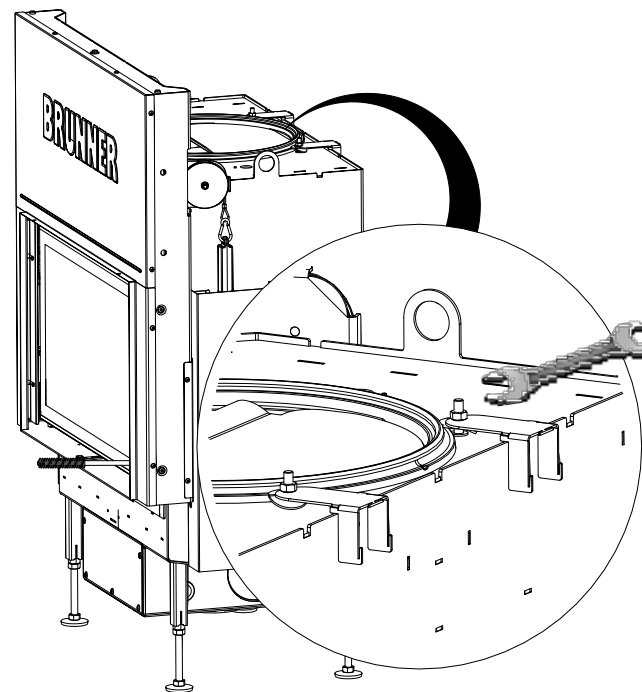

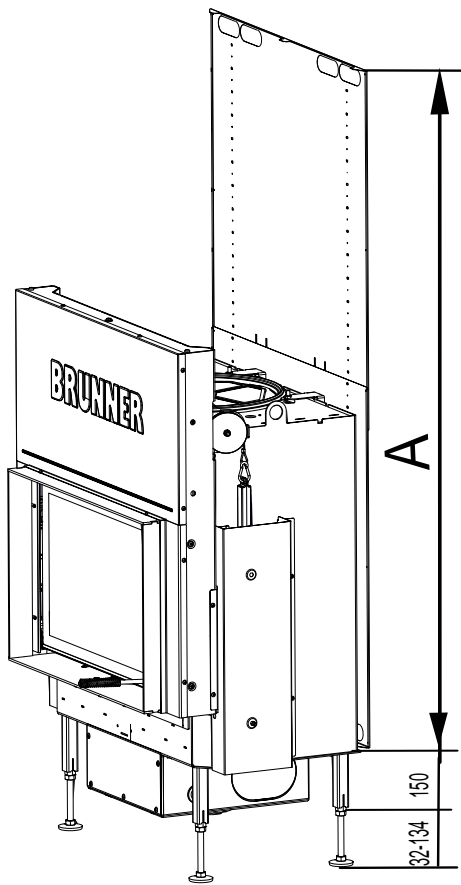

Variant **A** (A= max. 1665 mm)

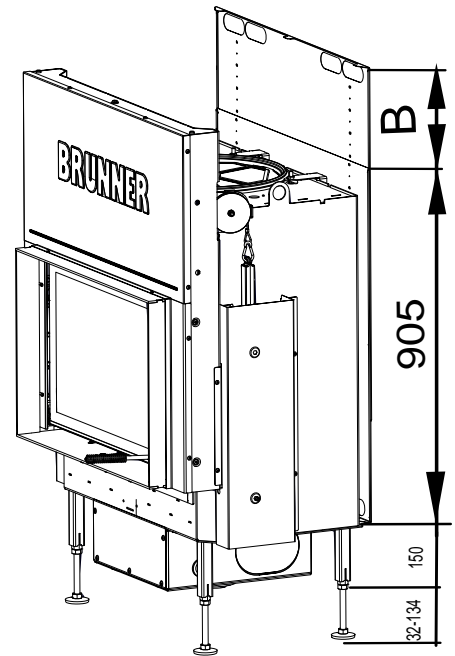

Variant **B** (B=min.760mm)



for variant A:

for variant B:

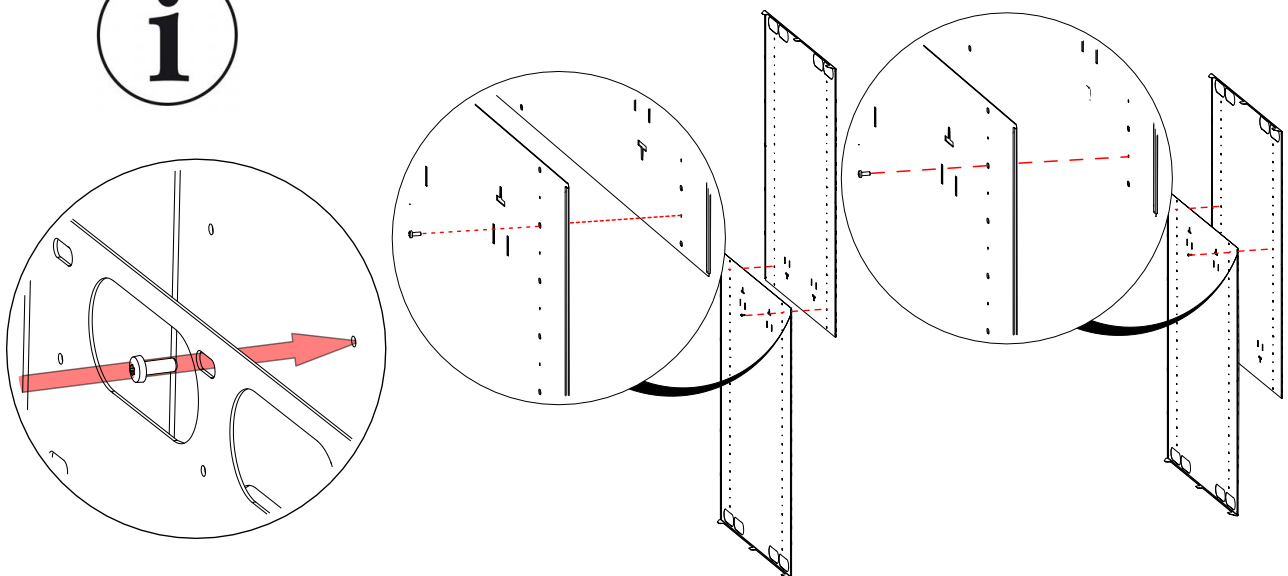

5

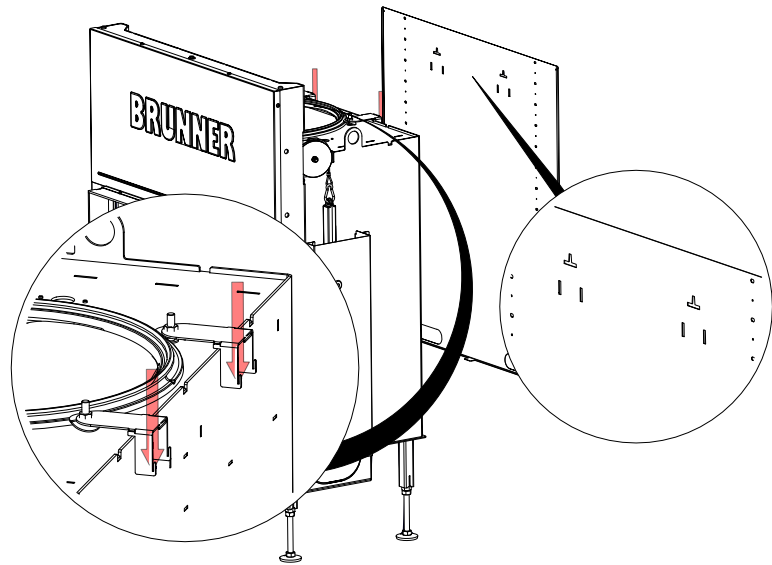

6

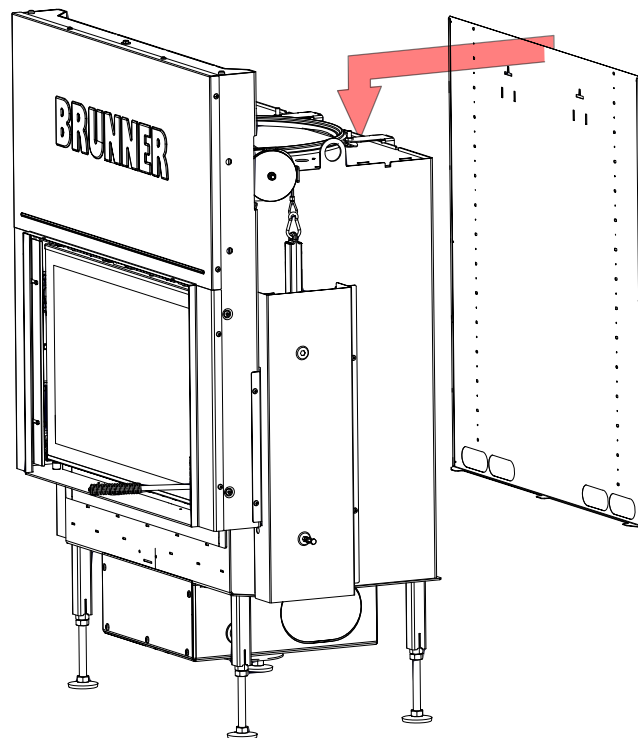

7

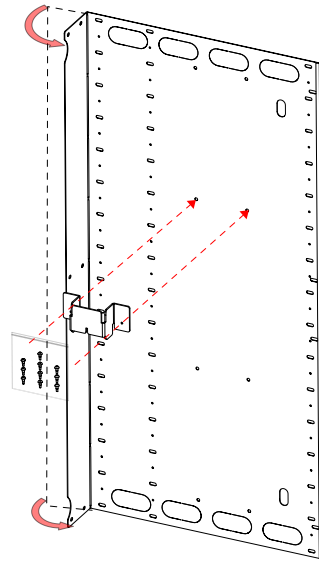

for variant A:

for variant B:

i

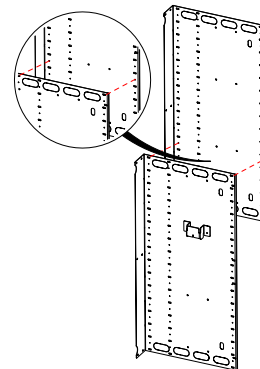
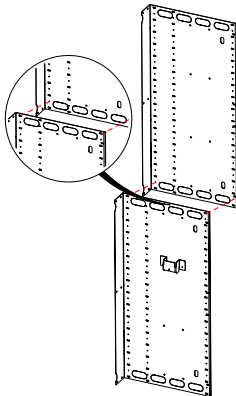

8

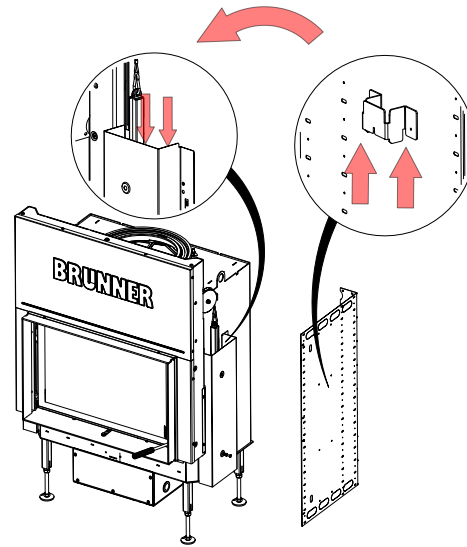

9

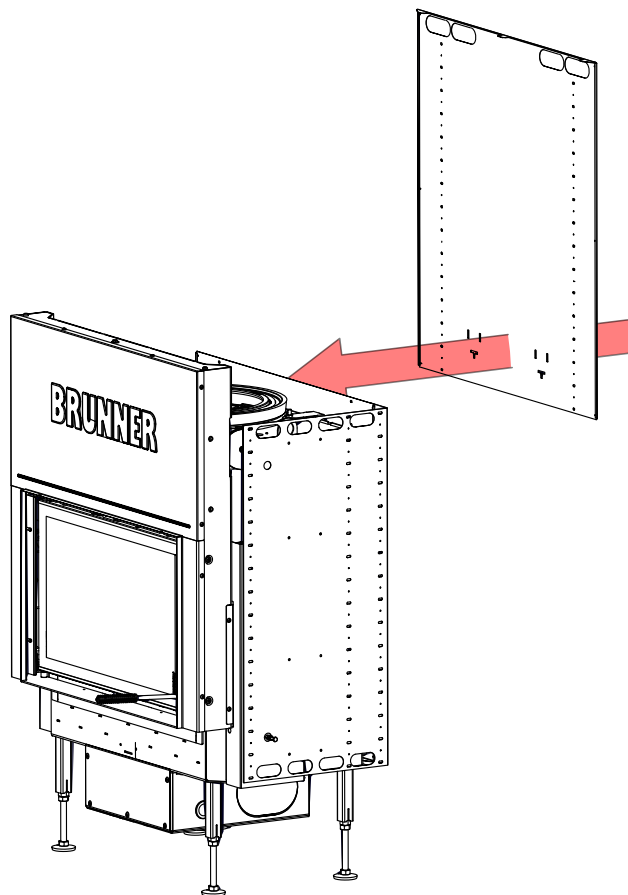

10

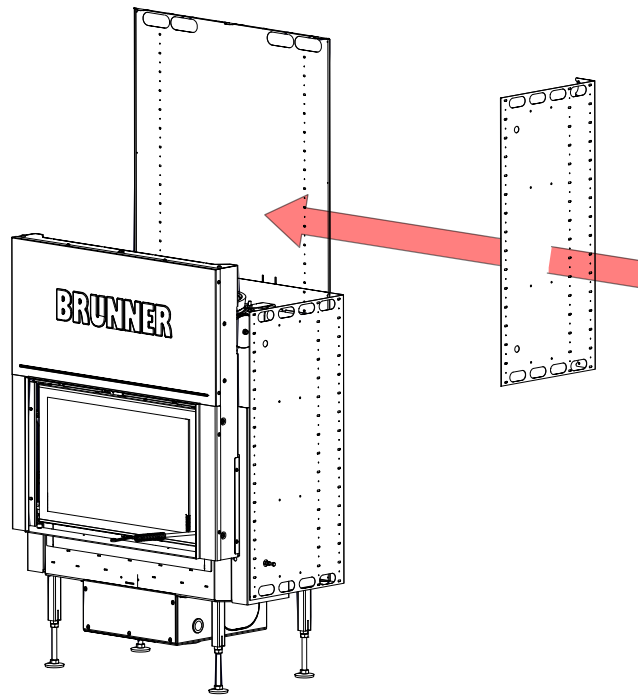

11

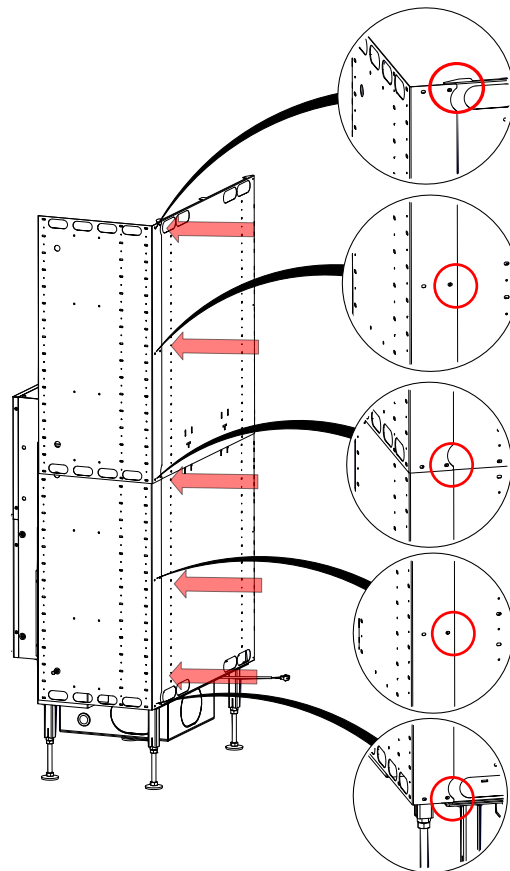

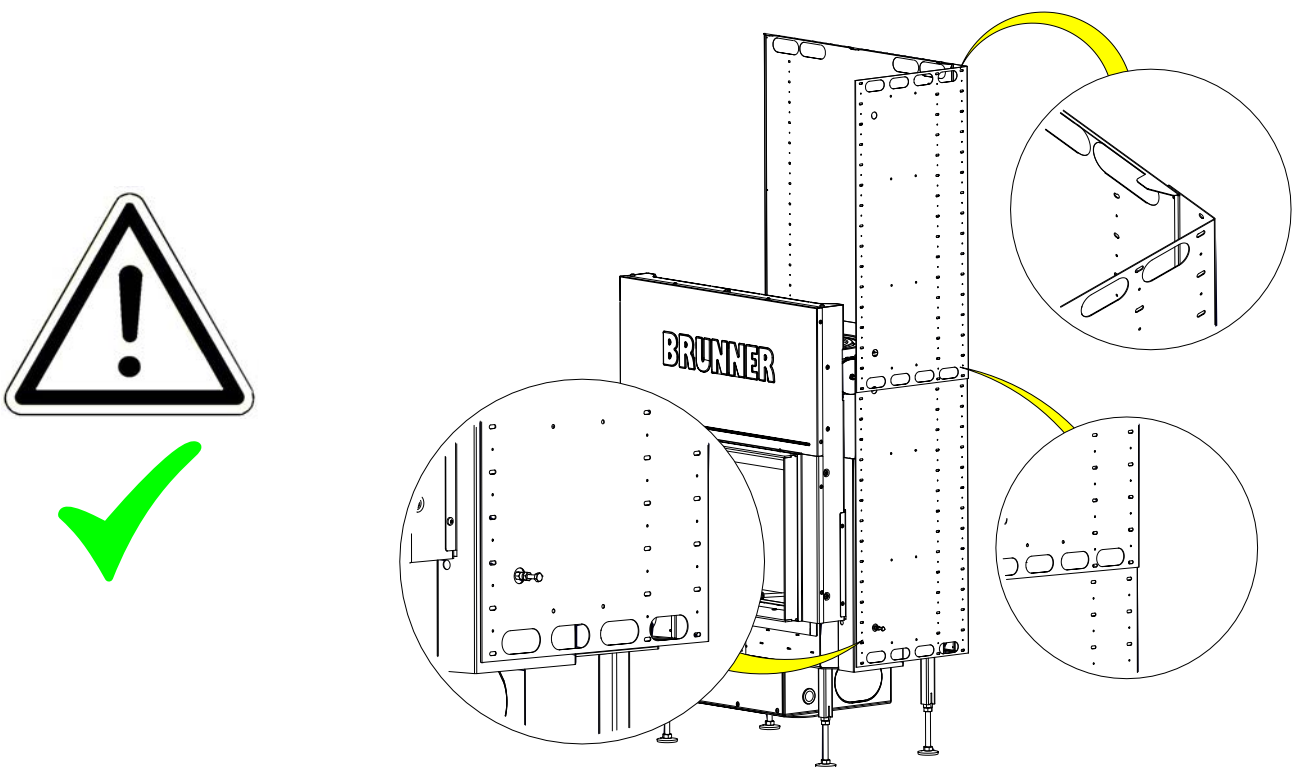

4.2.4 VARIANT WITH EXTERNAL COMBUSTION AIR CONNECTION

Preparatory work

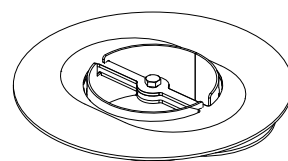

Workflow:

1

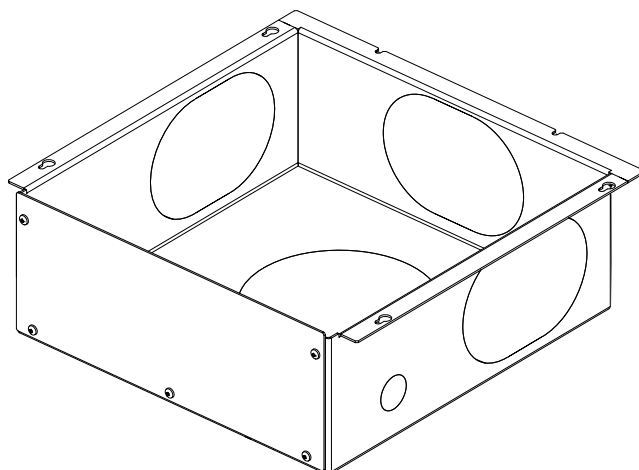

2

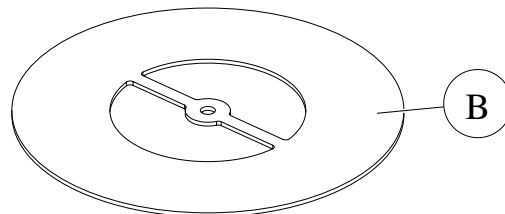
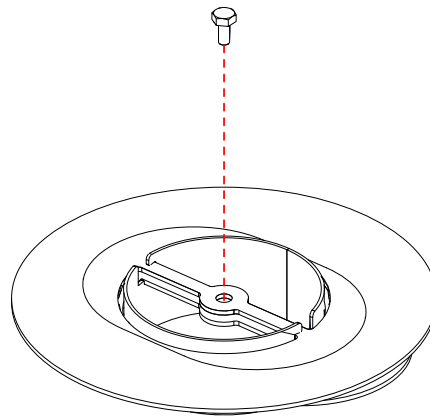

3

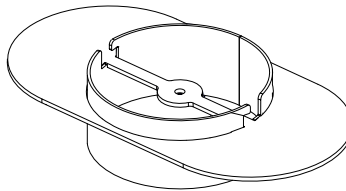
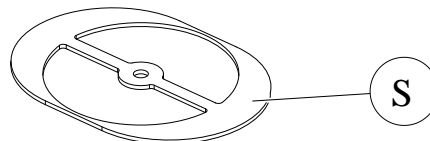

4

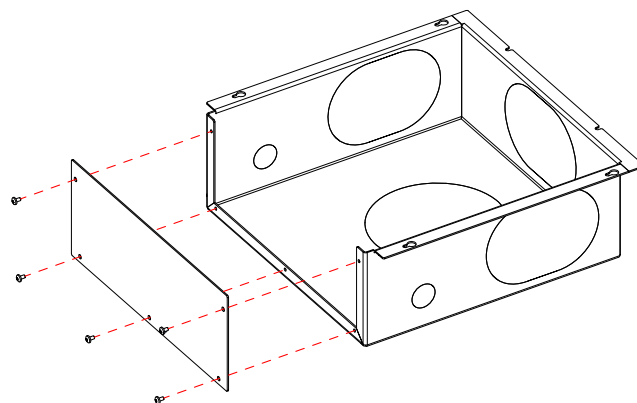

Im. 2: Recommended for easier handling

Depending on the planning, the air connection is possible - using aluxflex on 3 lateral parts (S) and also from the bottom (B).

Once you have made a decision, break out the appropriate part and make the connections for the air supply.

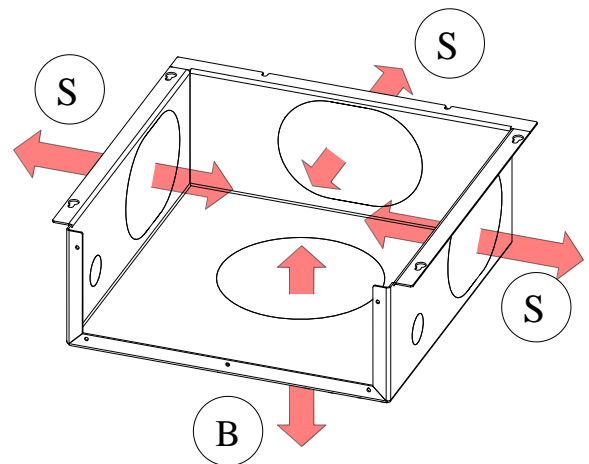

4.2.4.1 BOTTOM CONNECTION (B)

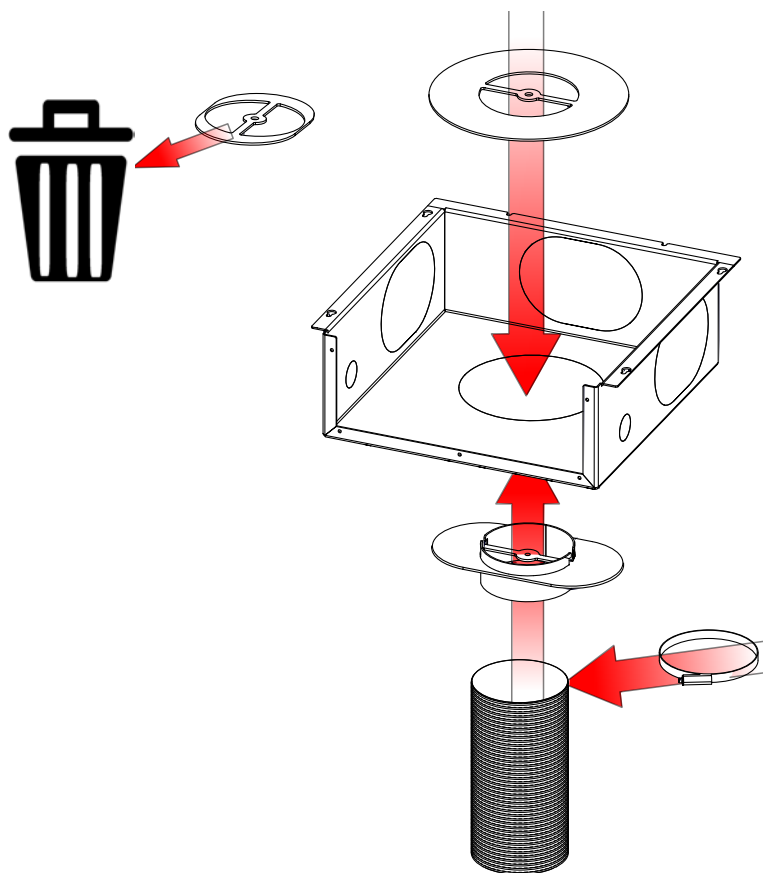

Im. 3: Summarised information

Workflow:

5

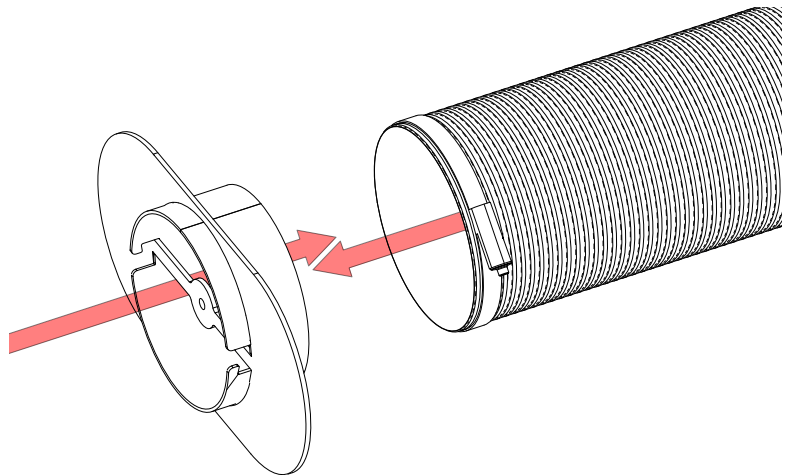

6

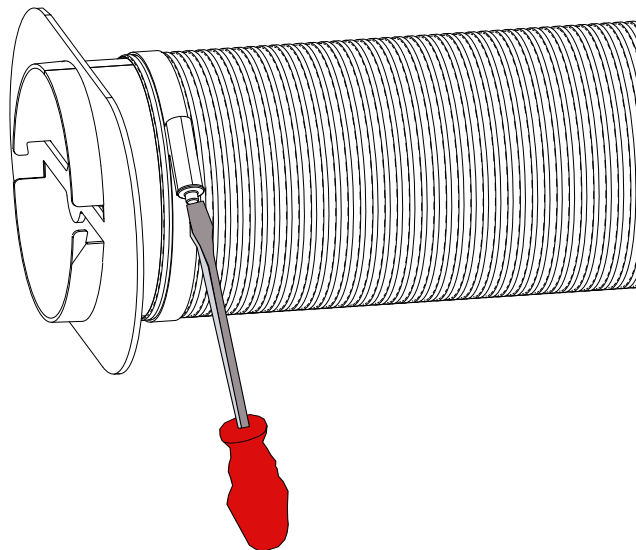

7

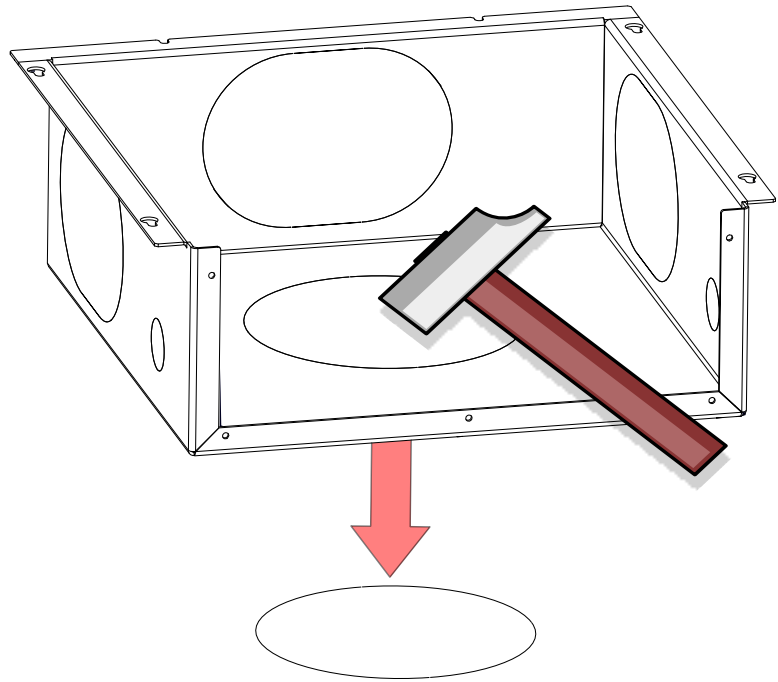

8

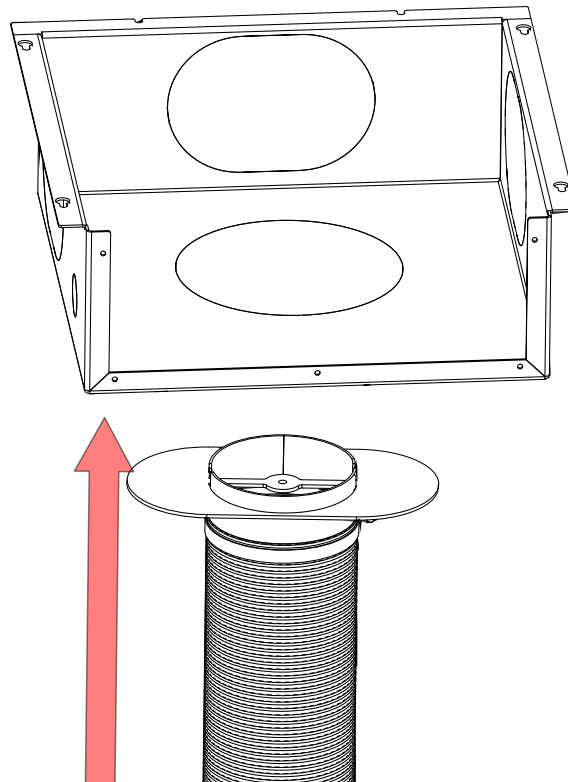

9

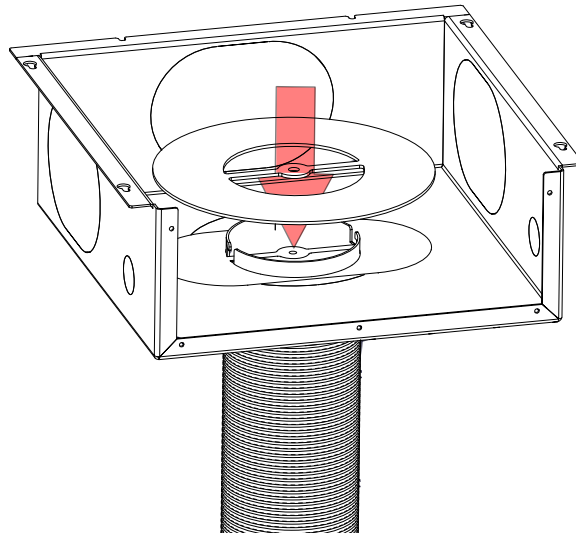

10

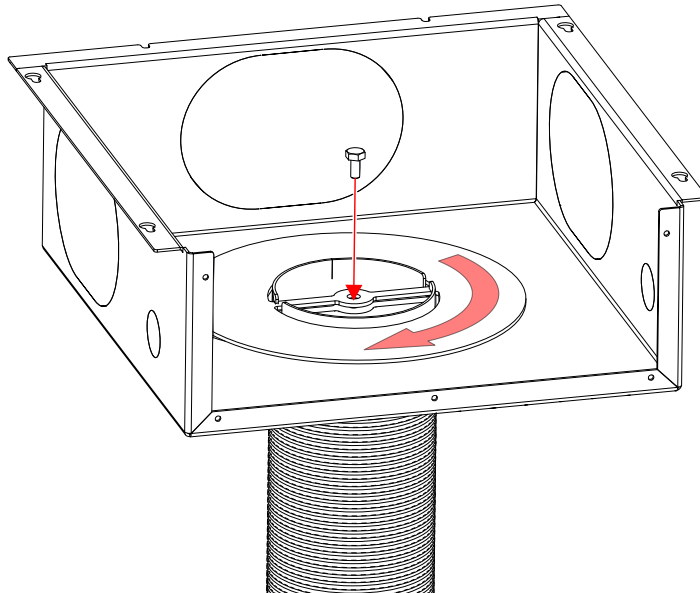

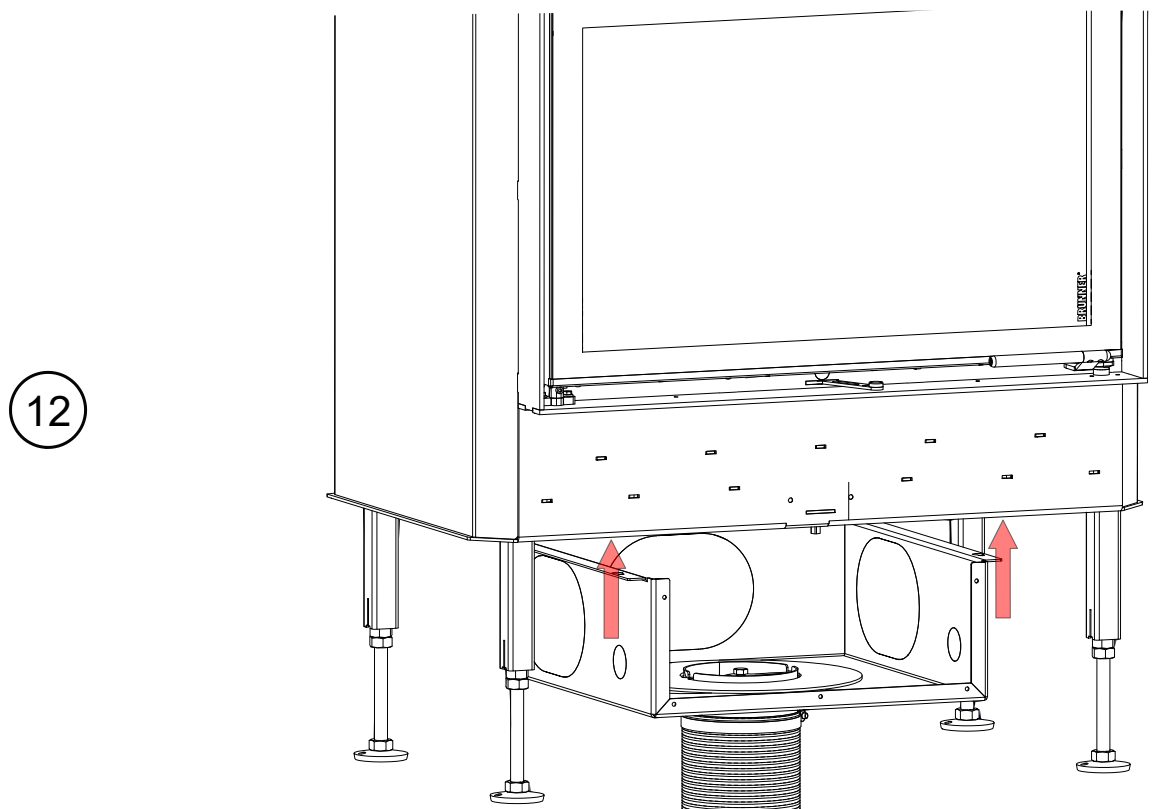
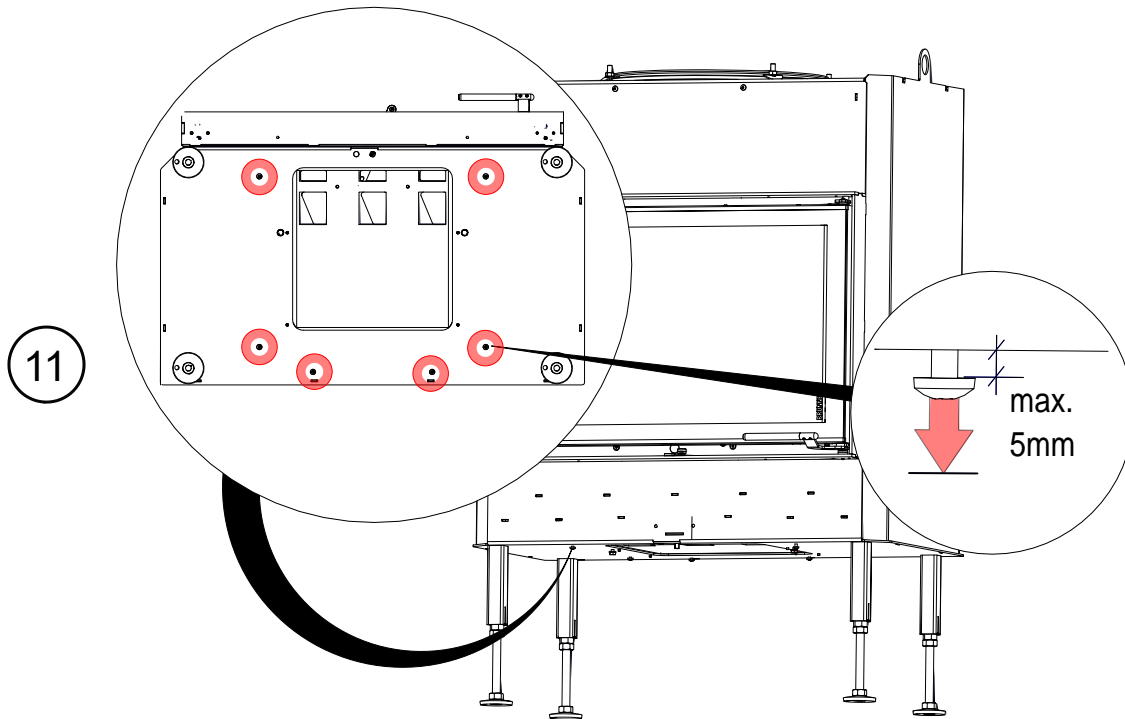

13

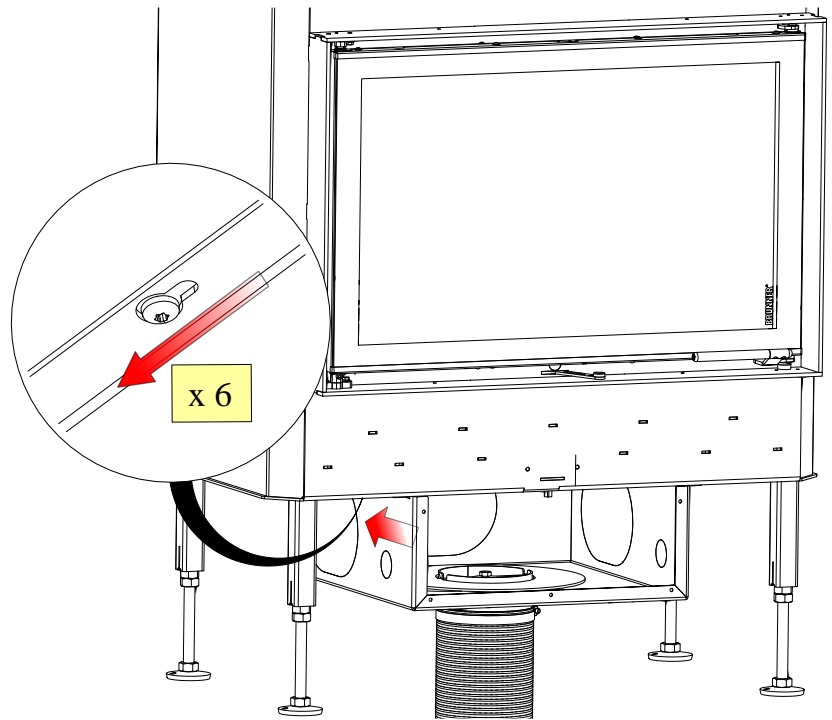

14

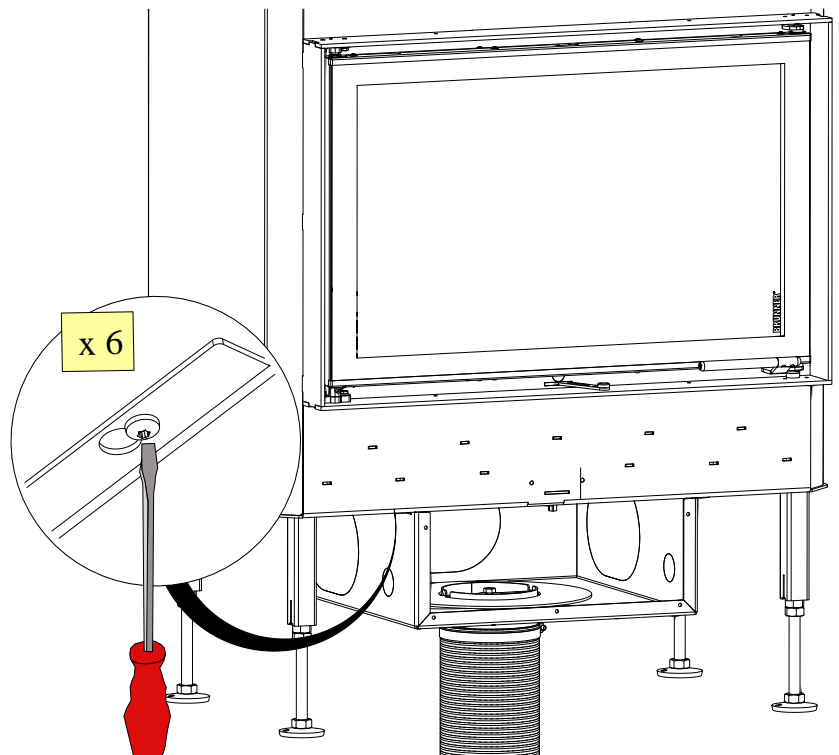

15

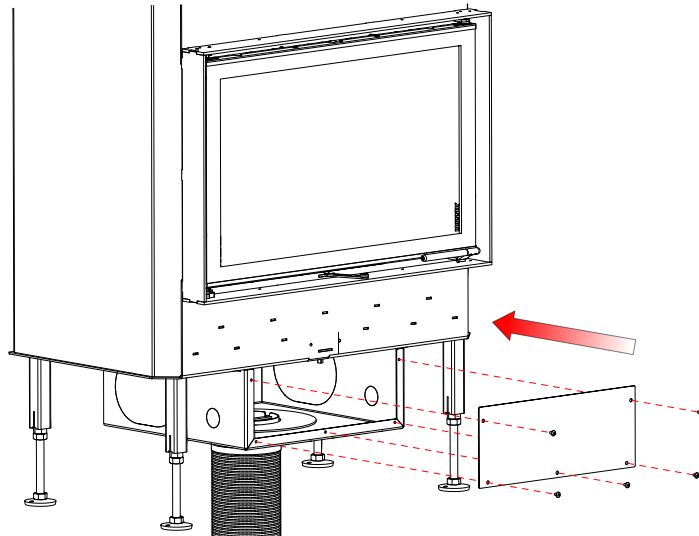

4.2.4.2 SIDE CONNECTION (S)

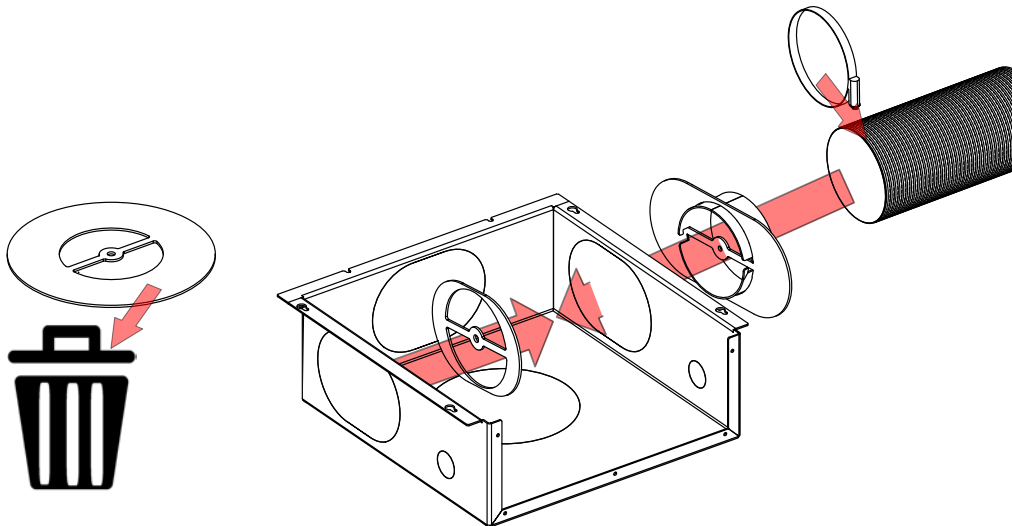

Im. 4: Summarised information

Workflow:

5

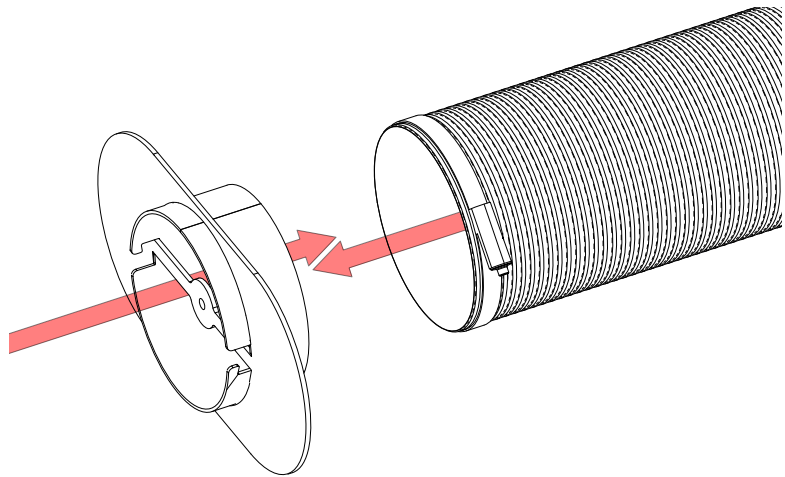

6

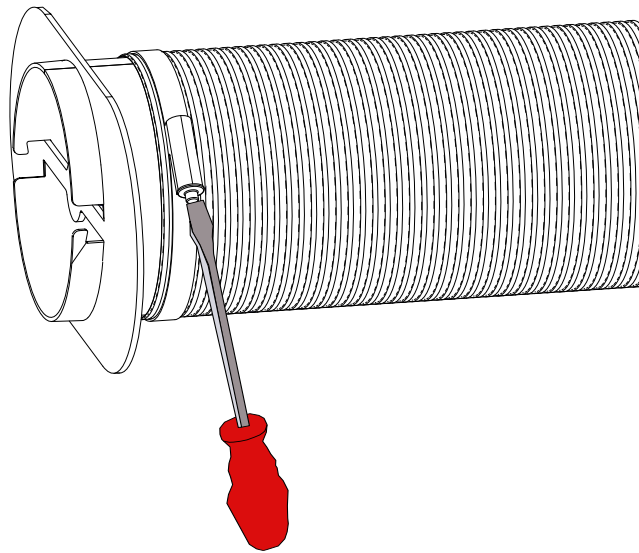

7

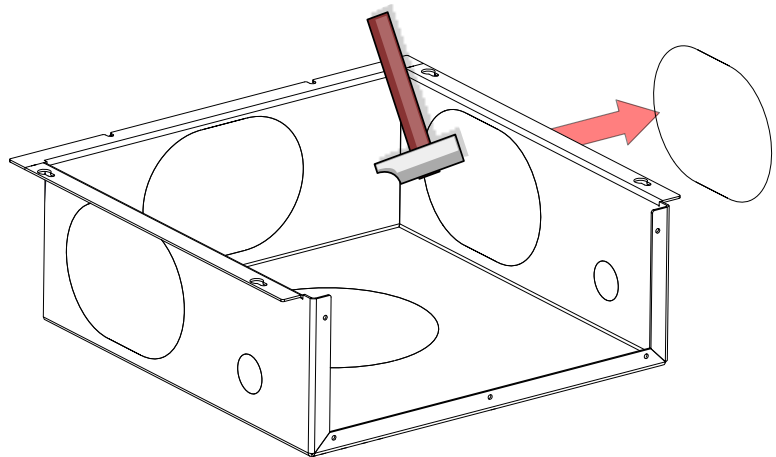

8

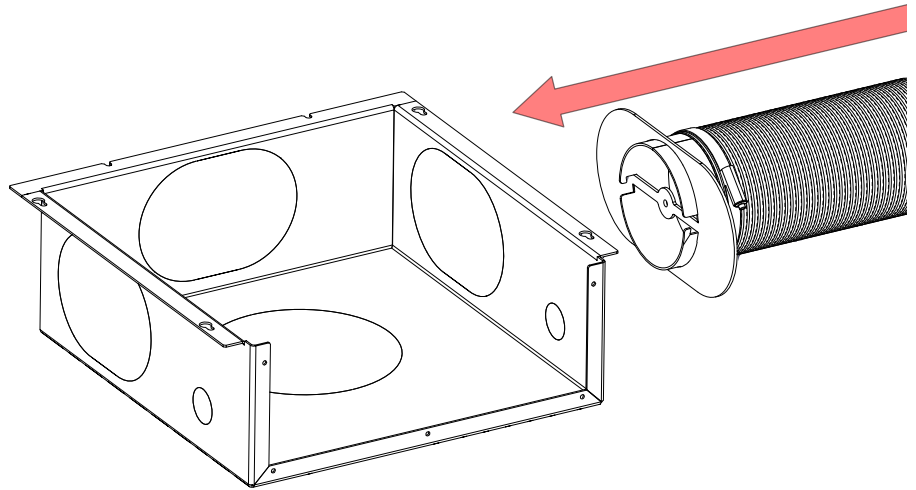

9

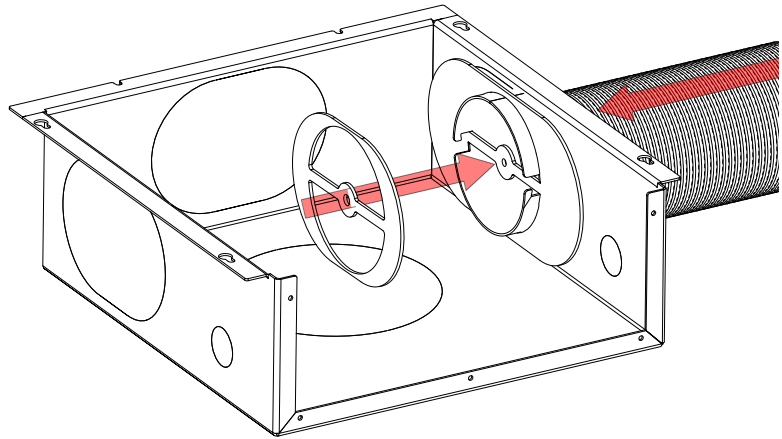

10

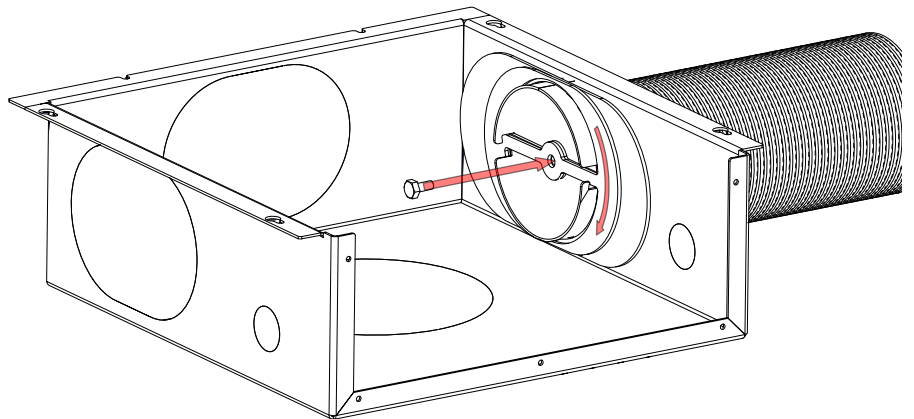

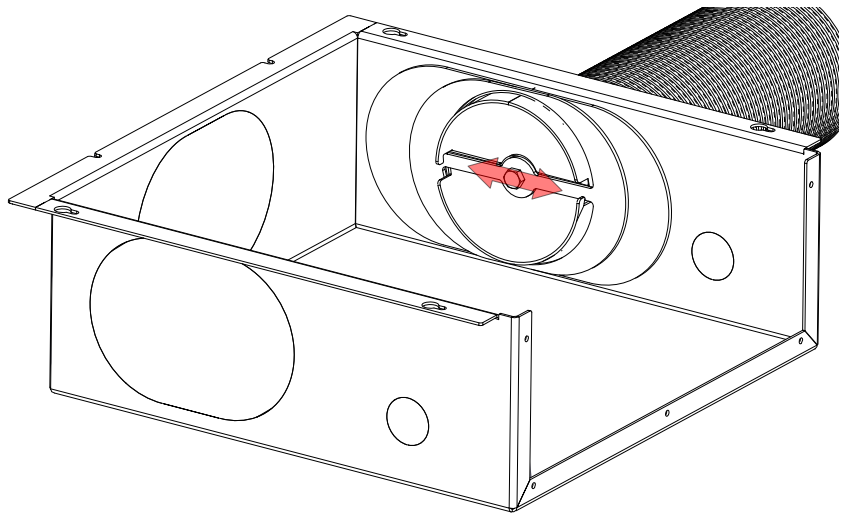

11

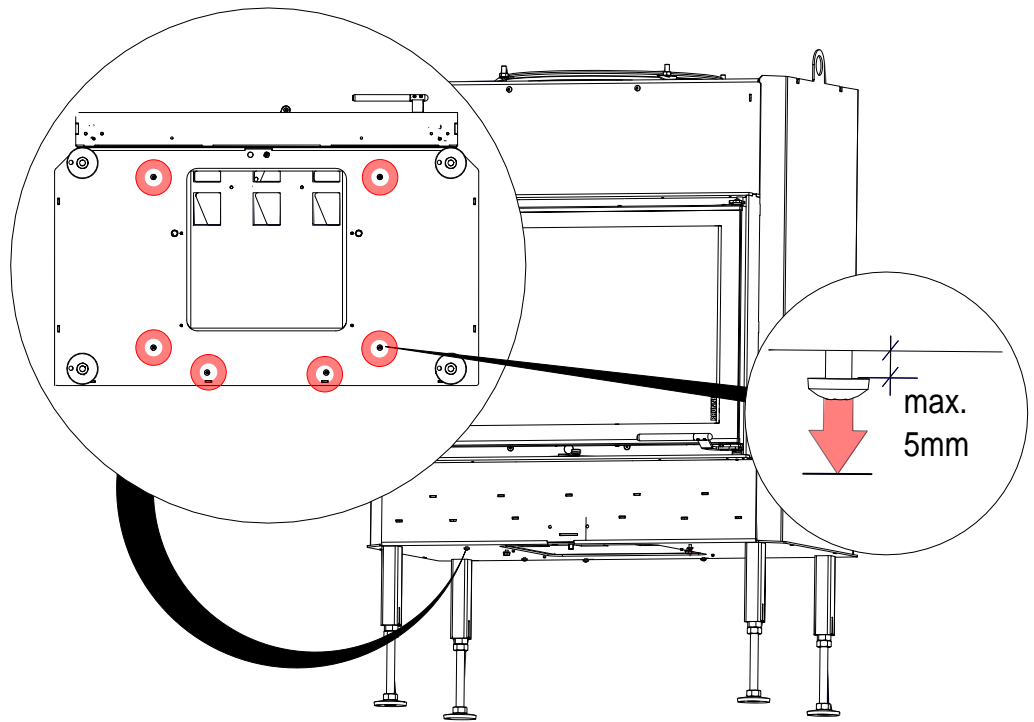

12

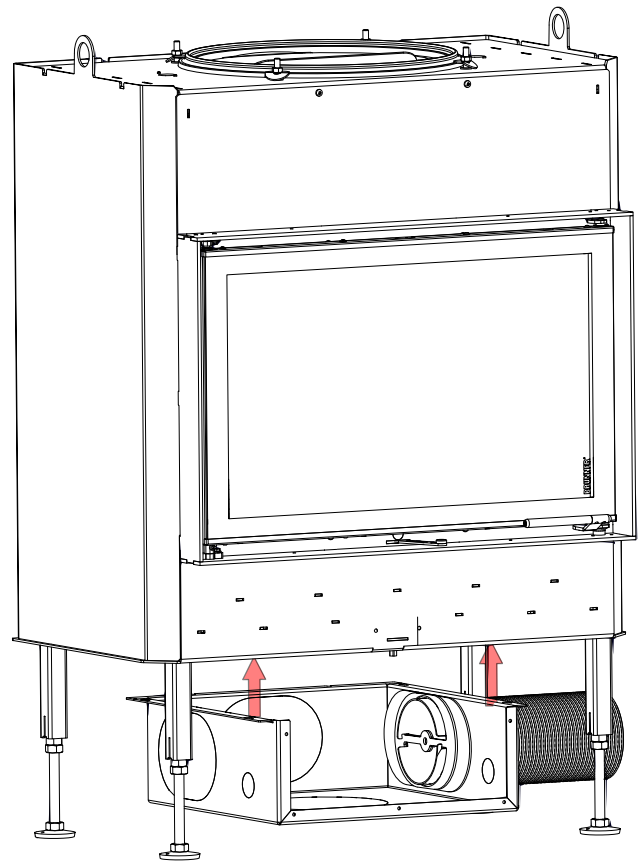

13

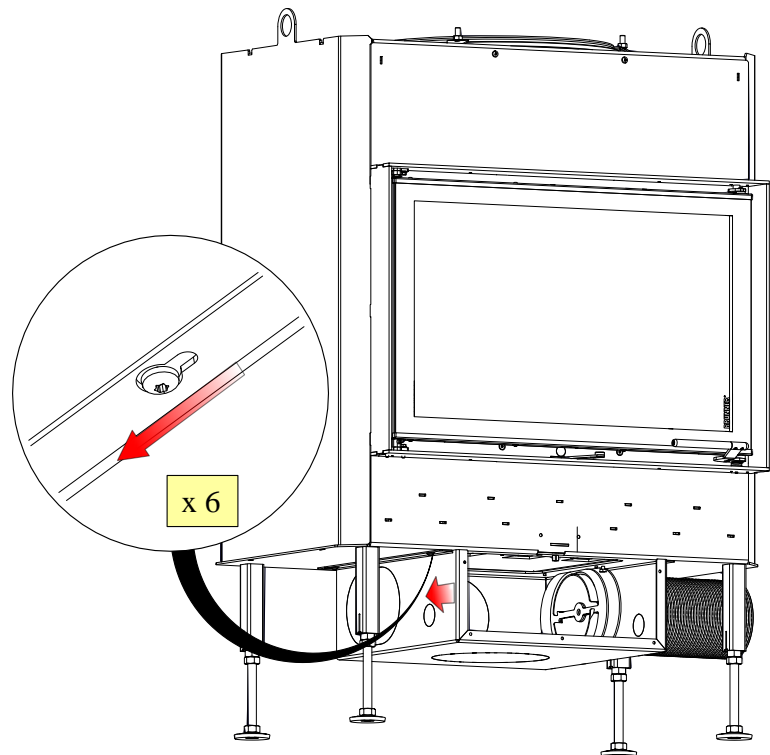

14

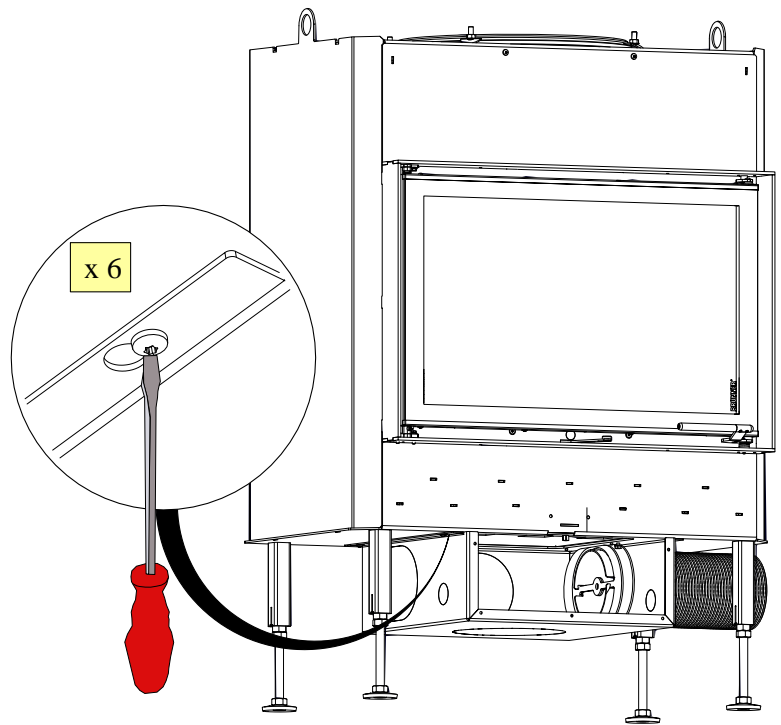

15

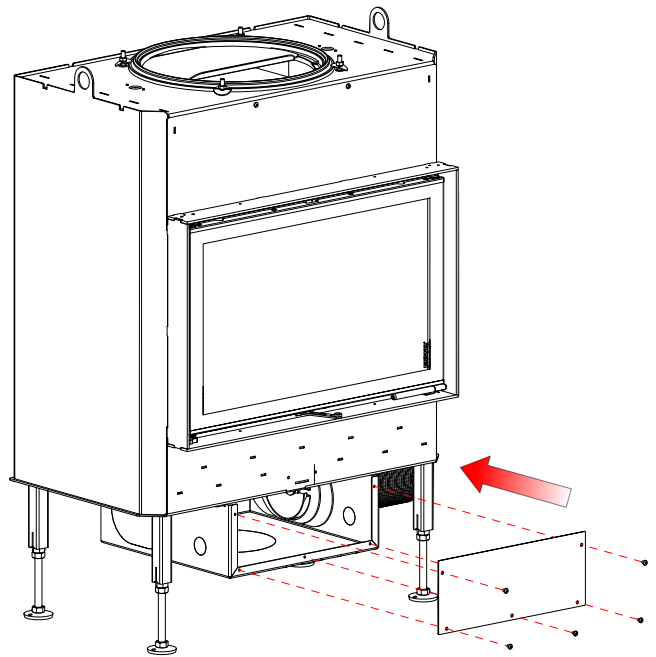

4.3 FITTING: CATALYTIC CONVERTER

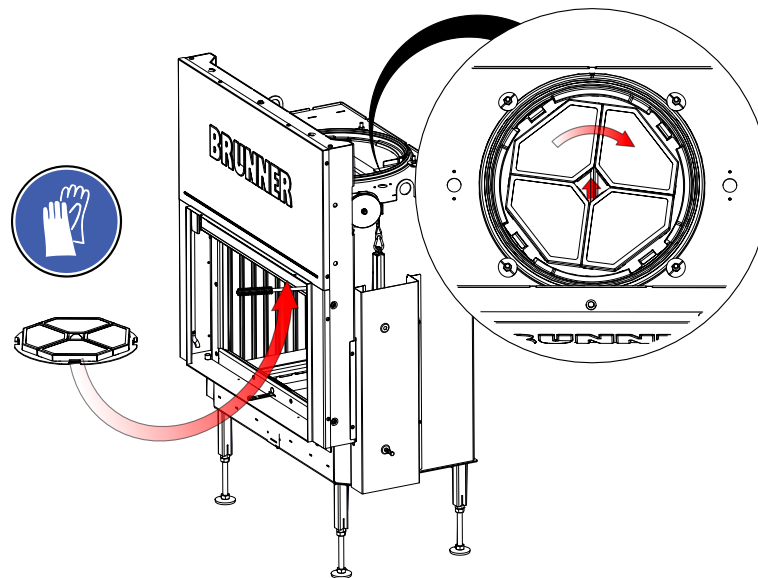

Im. 5: Summarised information

1

| | |
|-------|---------------------|
| 1 | catalytic converter |
| 2a+2b | assembly tool |

2a

2b

Workflow:

1

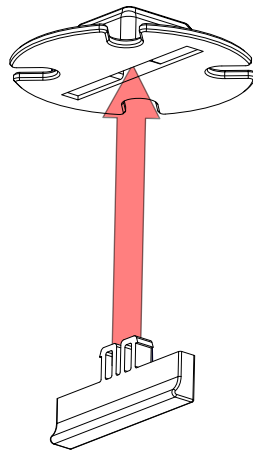

2

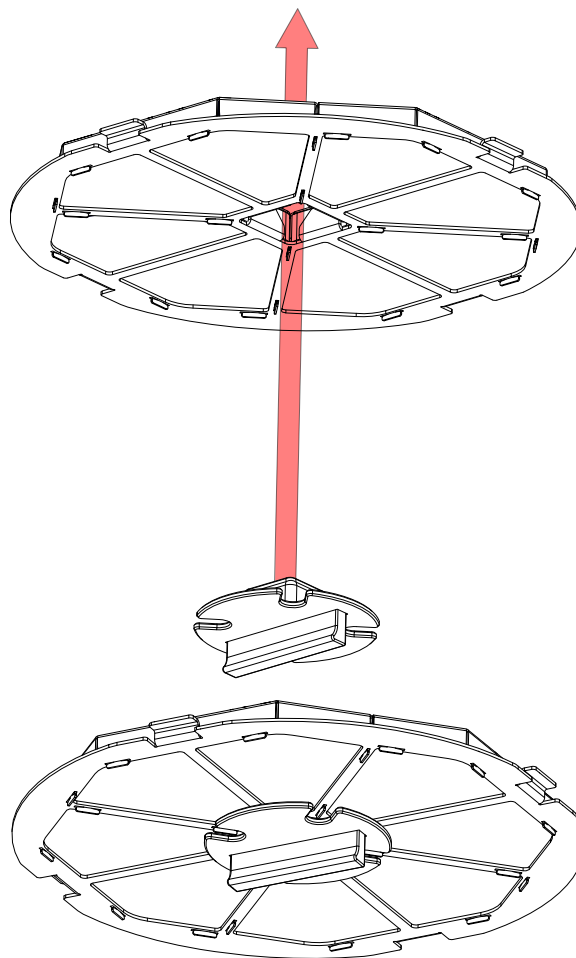

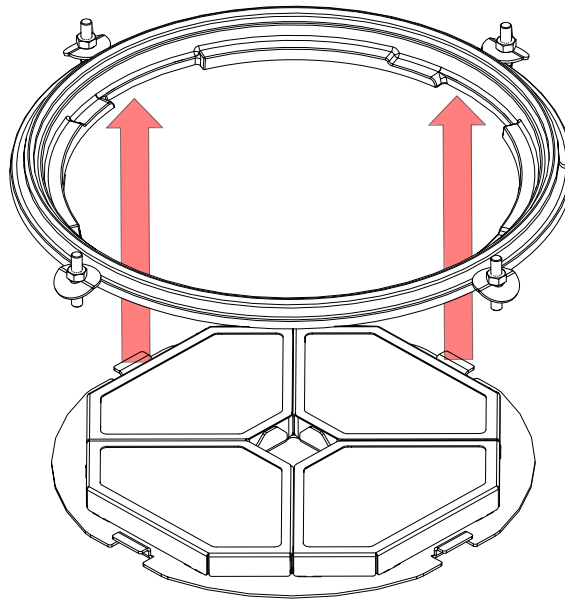

3

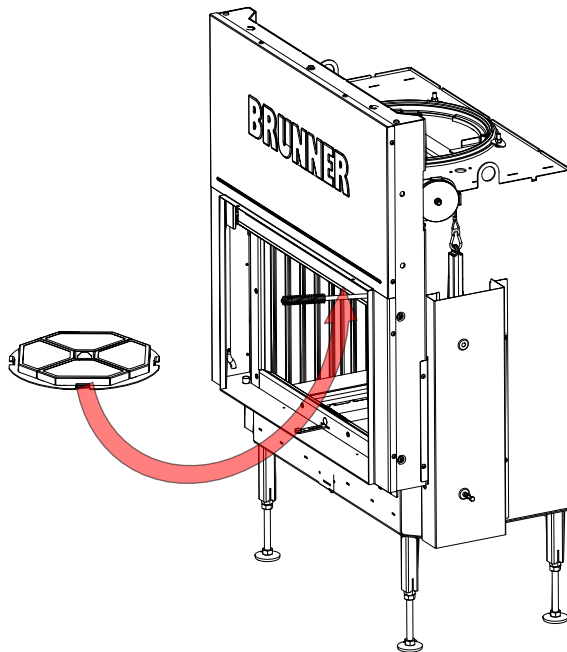

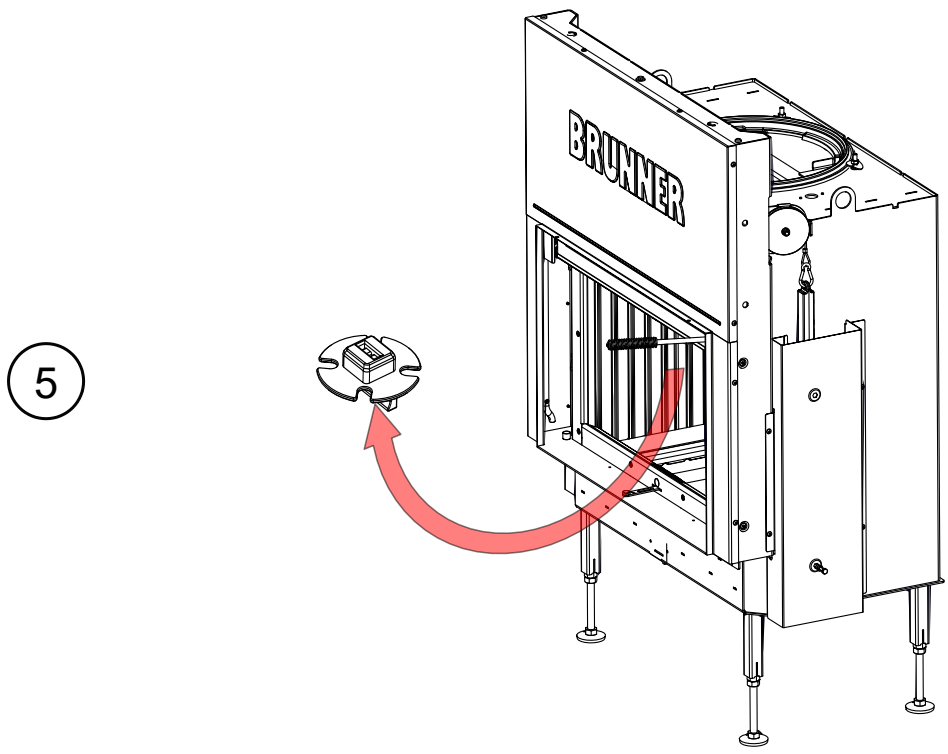
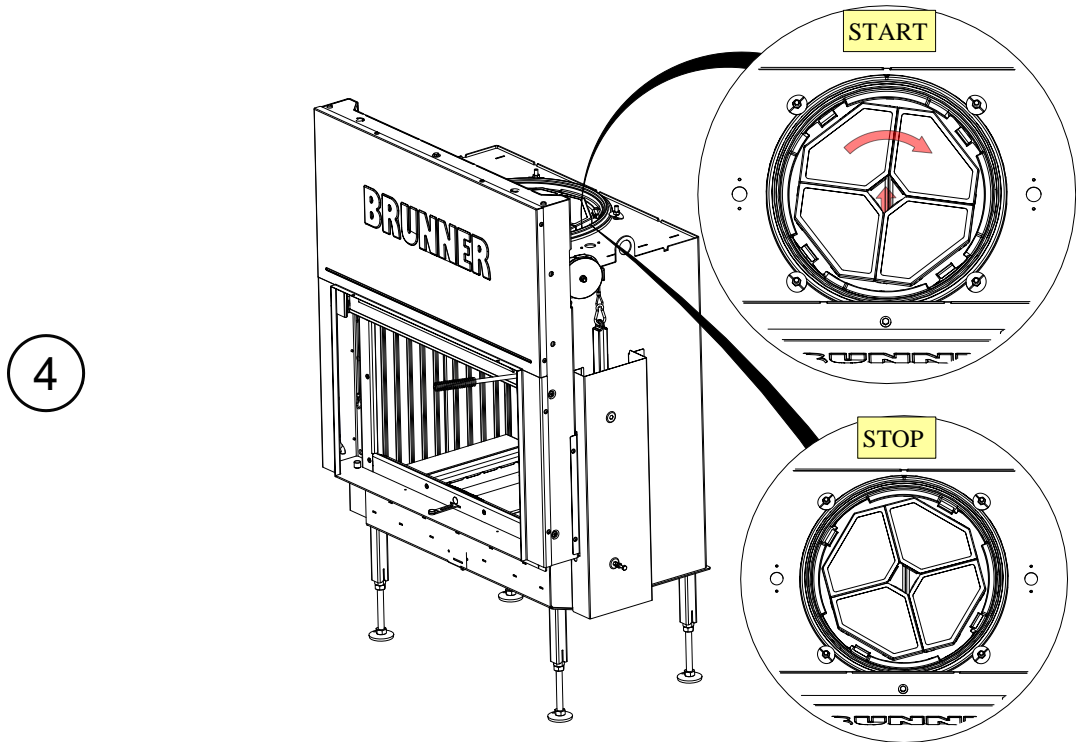

4.4 FITTING: DEFLECTION - COMBUSTION CHAMBER

Summarised information:

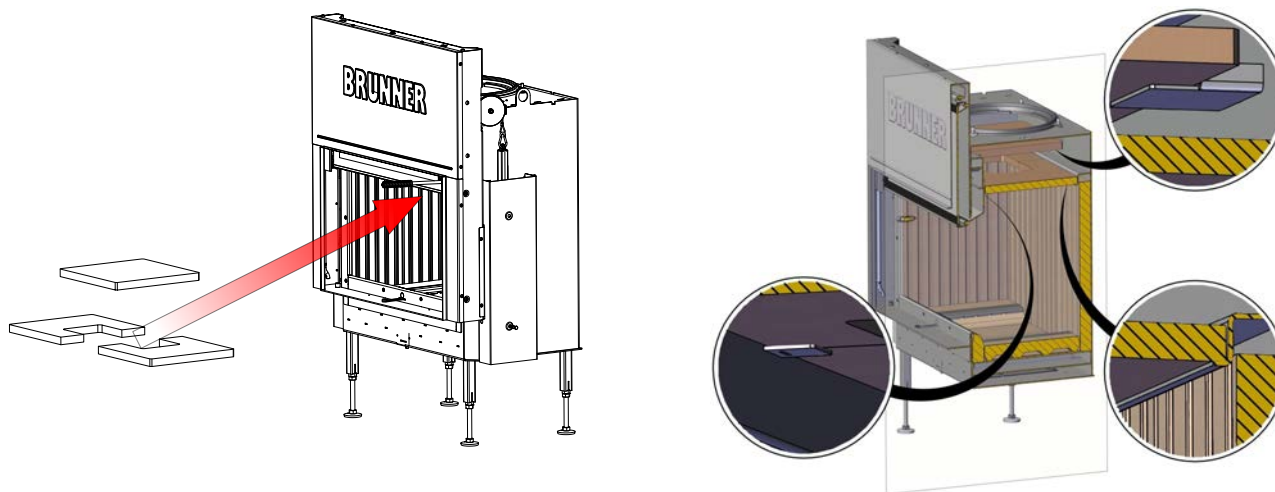

Montage

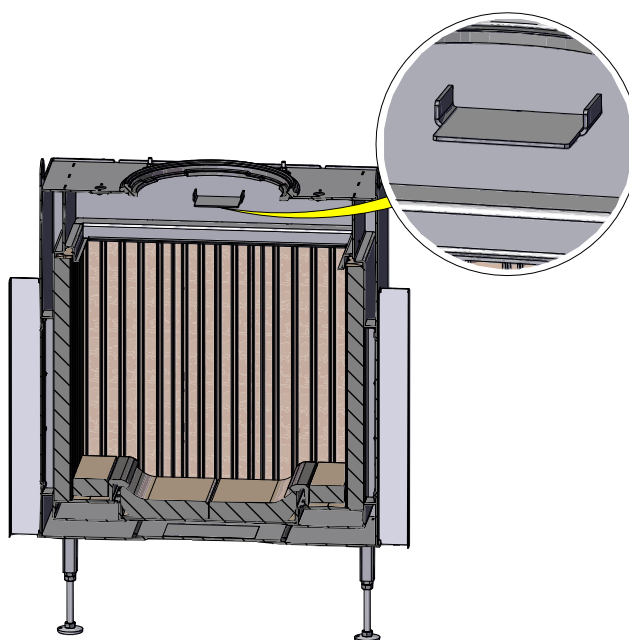
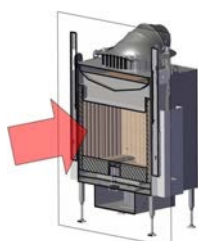
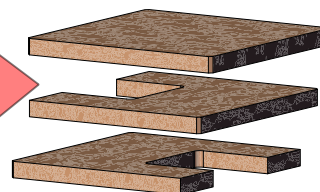

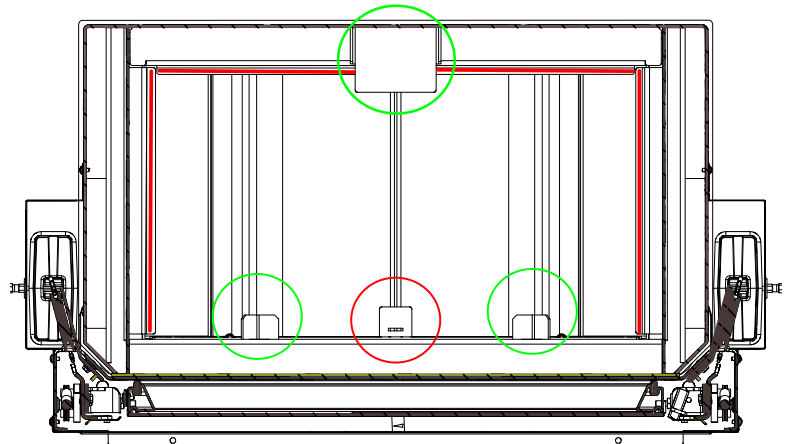
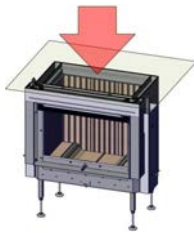

Im. 6: Support points for the deflection plates

Workflow:

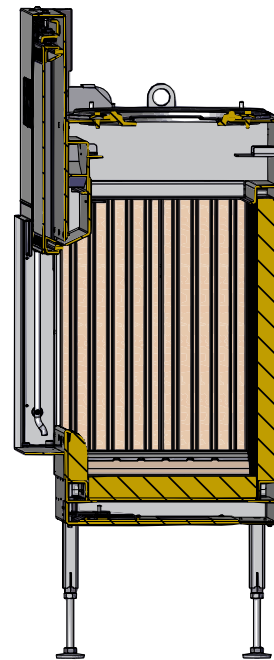
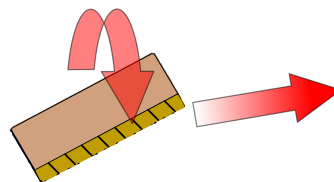

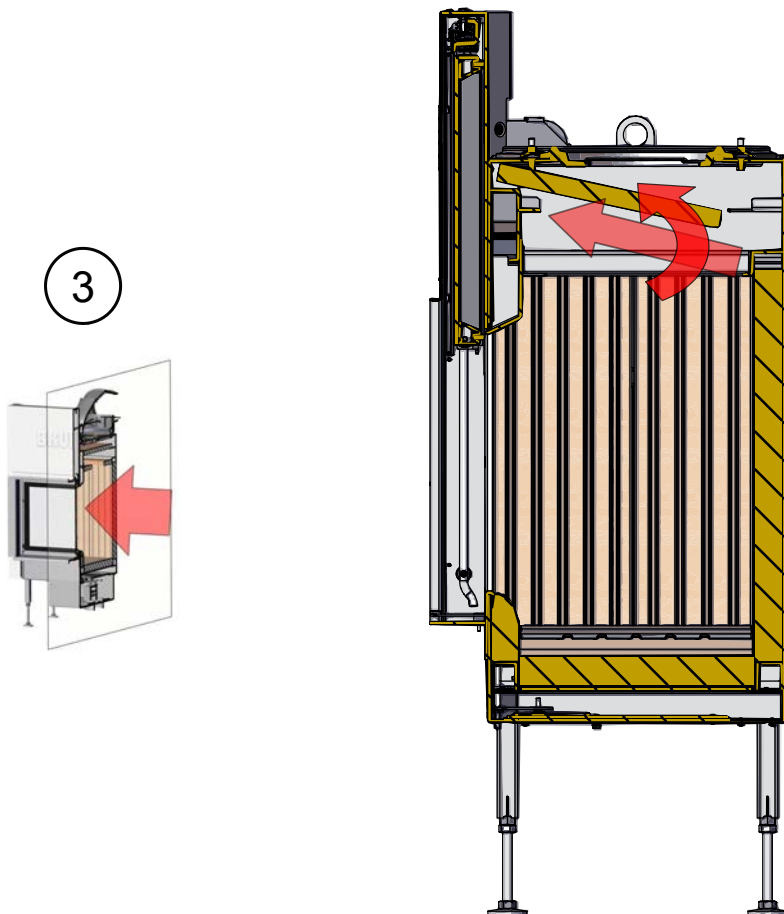
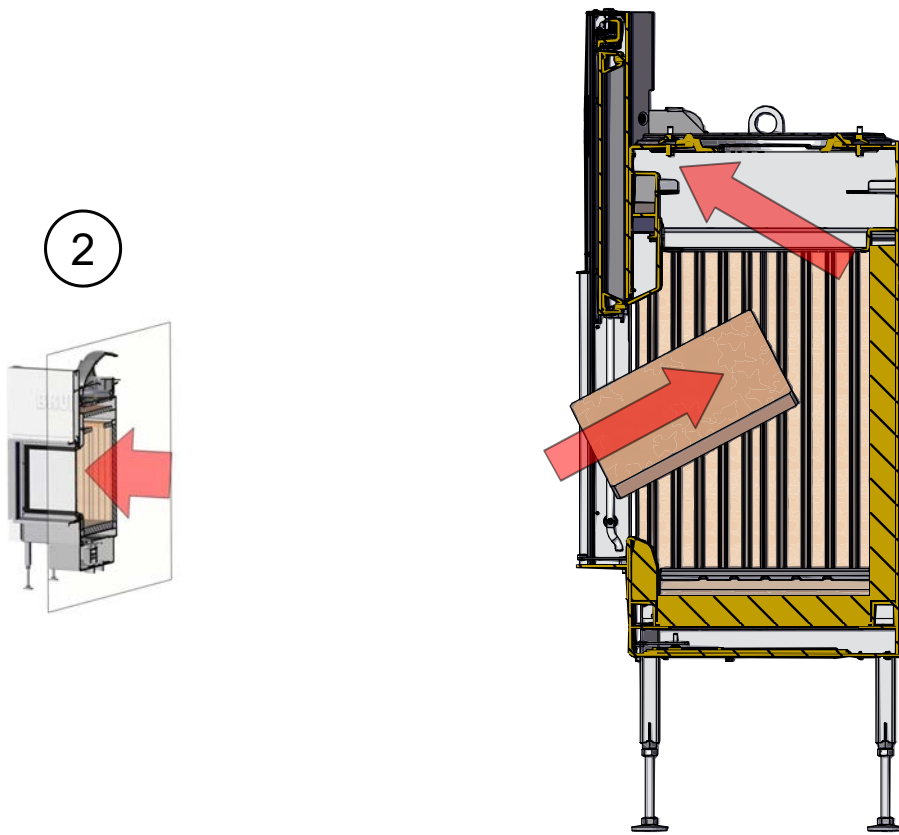

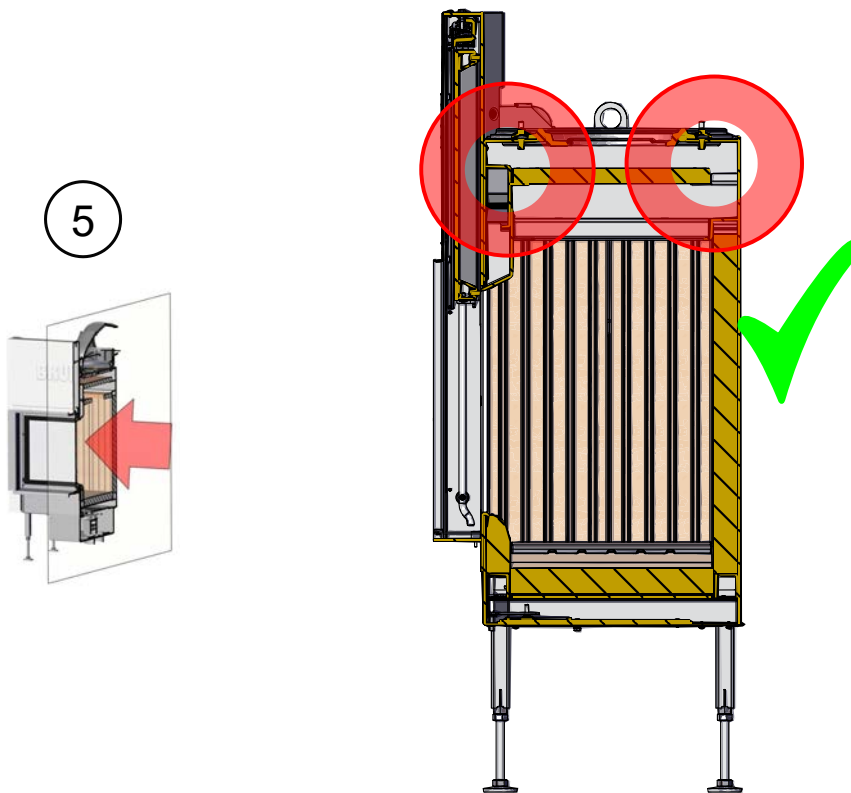
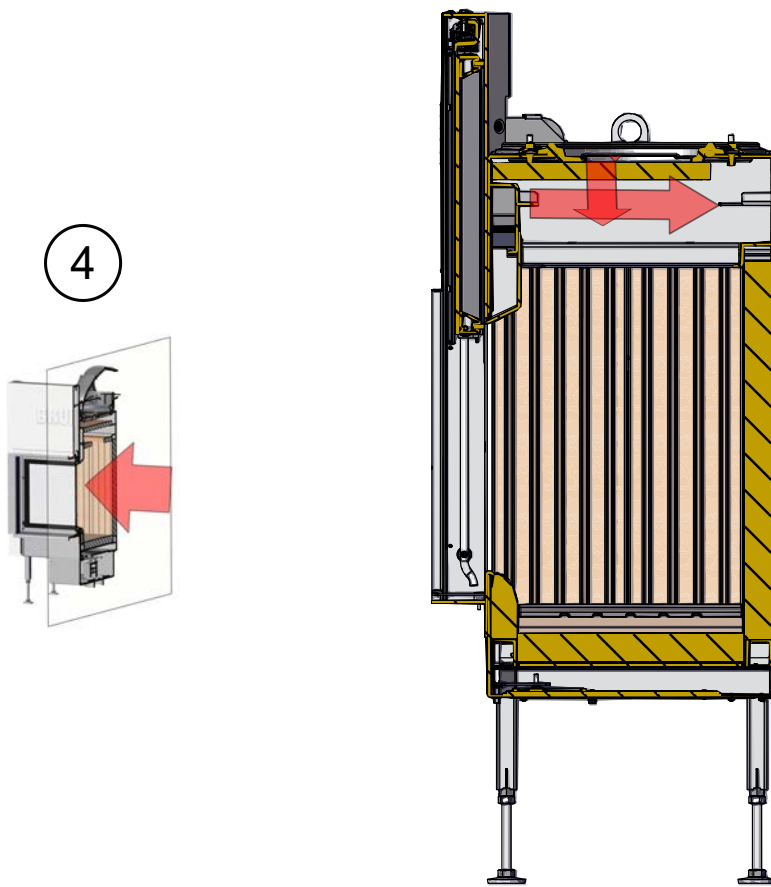

6

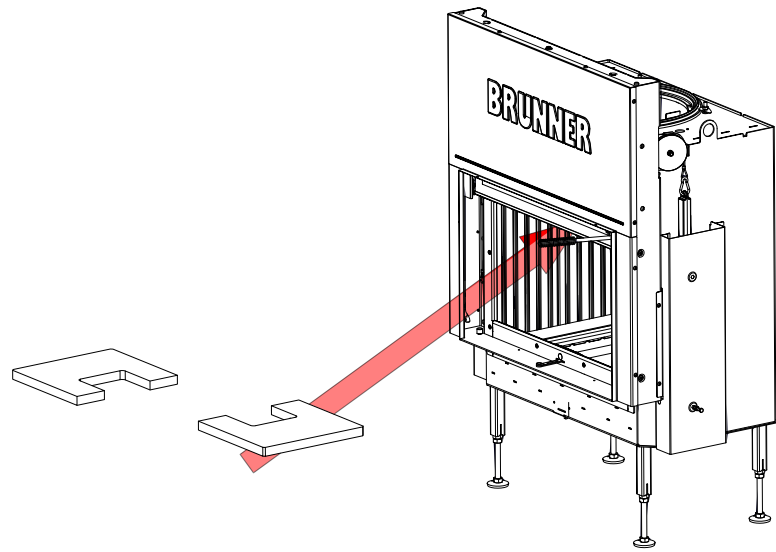

7

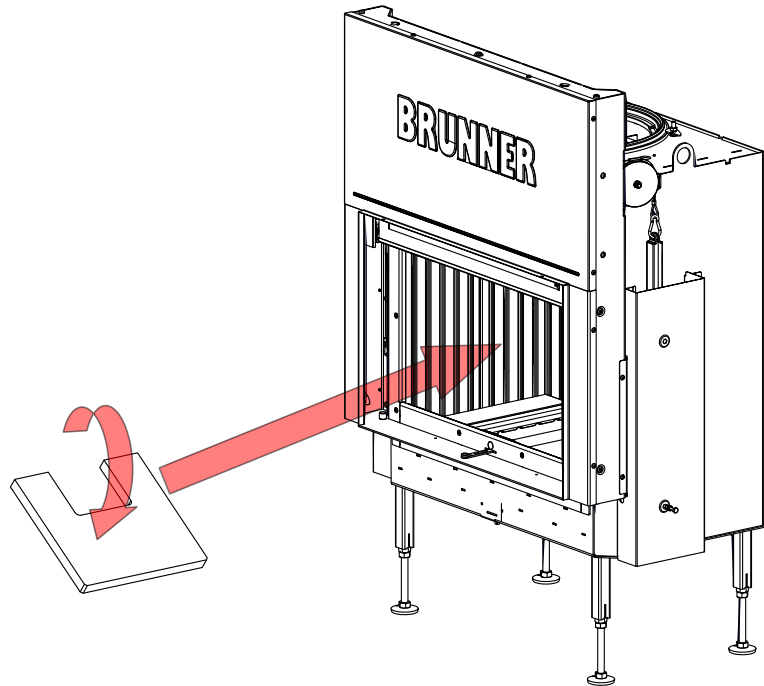

8

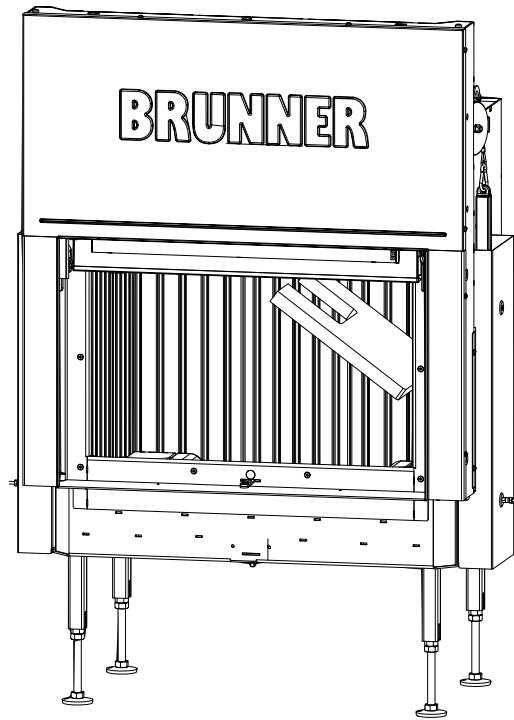

9

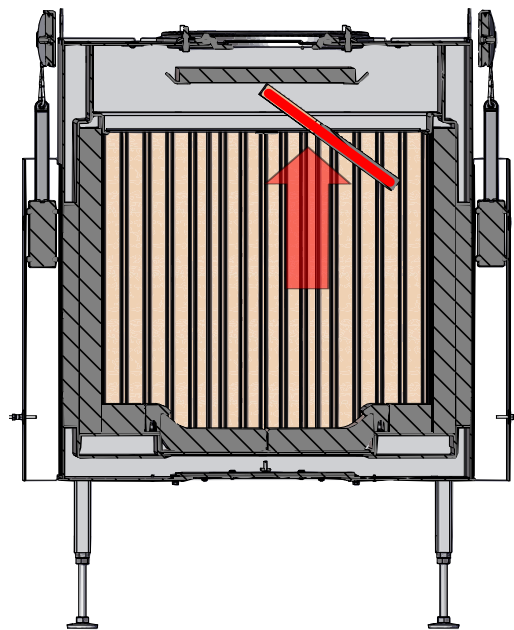
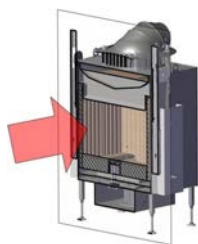

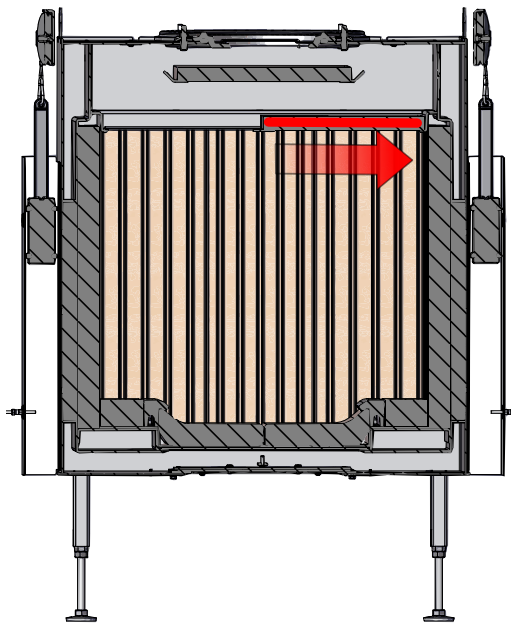
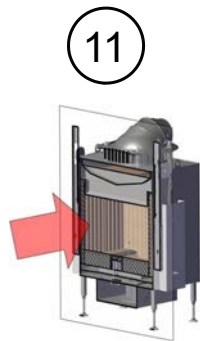
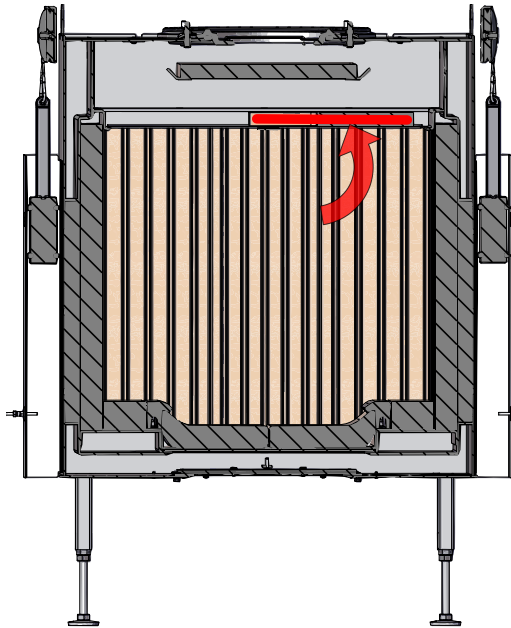
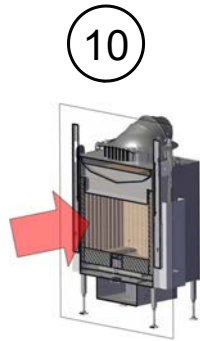

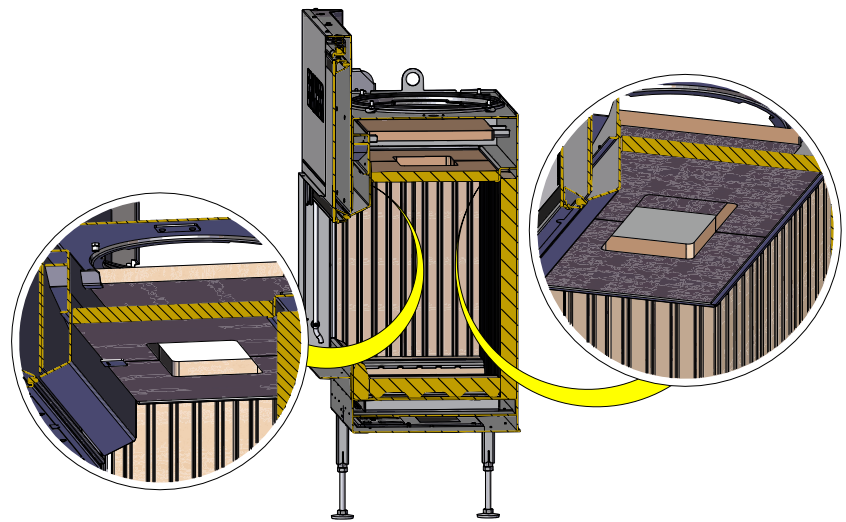
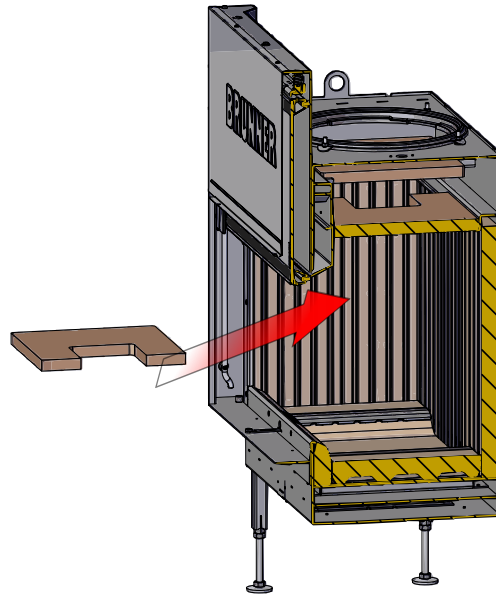
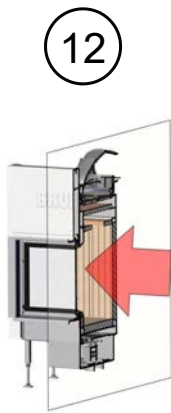

4.5 VARIANTS COMBUSTION CHAMBER LINING

4.5.1 CHAMOTTE INNER LINING

flat 42-42 (HK001200-01)

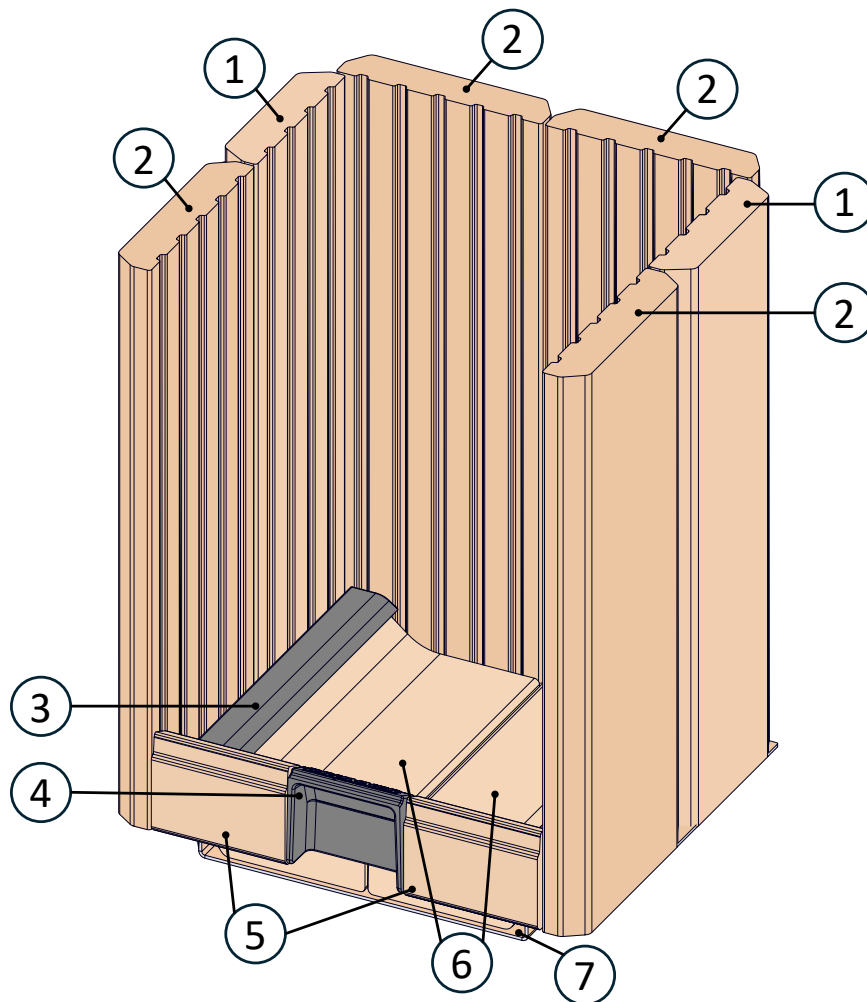

| Position | Designation | Art. No. | Pcs. |
|----------|-----------------------|----------|------|
| 1 | Stone 572x173x40 | HK000011 | 2 |
| 2 | Stone 572x203x40 | HK000012 | 4 |
| 3 | Cast air distributor | HK000006 | 2 |
| 4 | Cast inlay front | HK000007 | 1 |
| 5 | Wedge stone 132x99x40 | HK001204 | 2 |
| 6 | Bottom stone | HK001206 | 2 |
| 7 | Bottom insulation | HK001207 | 1 |



Chamotte inner lining to be installed dry

4.6 VARIANTS HEAT EXCHANGER

4.6.1 CONNECTION WITH CATALYTIC CONVERTER

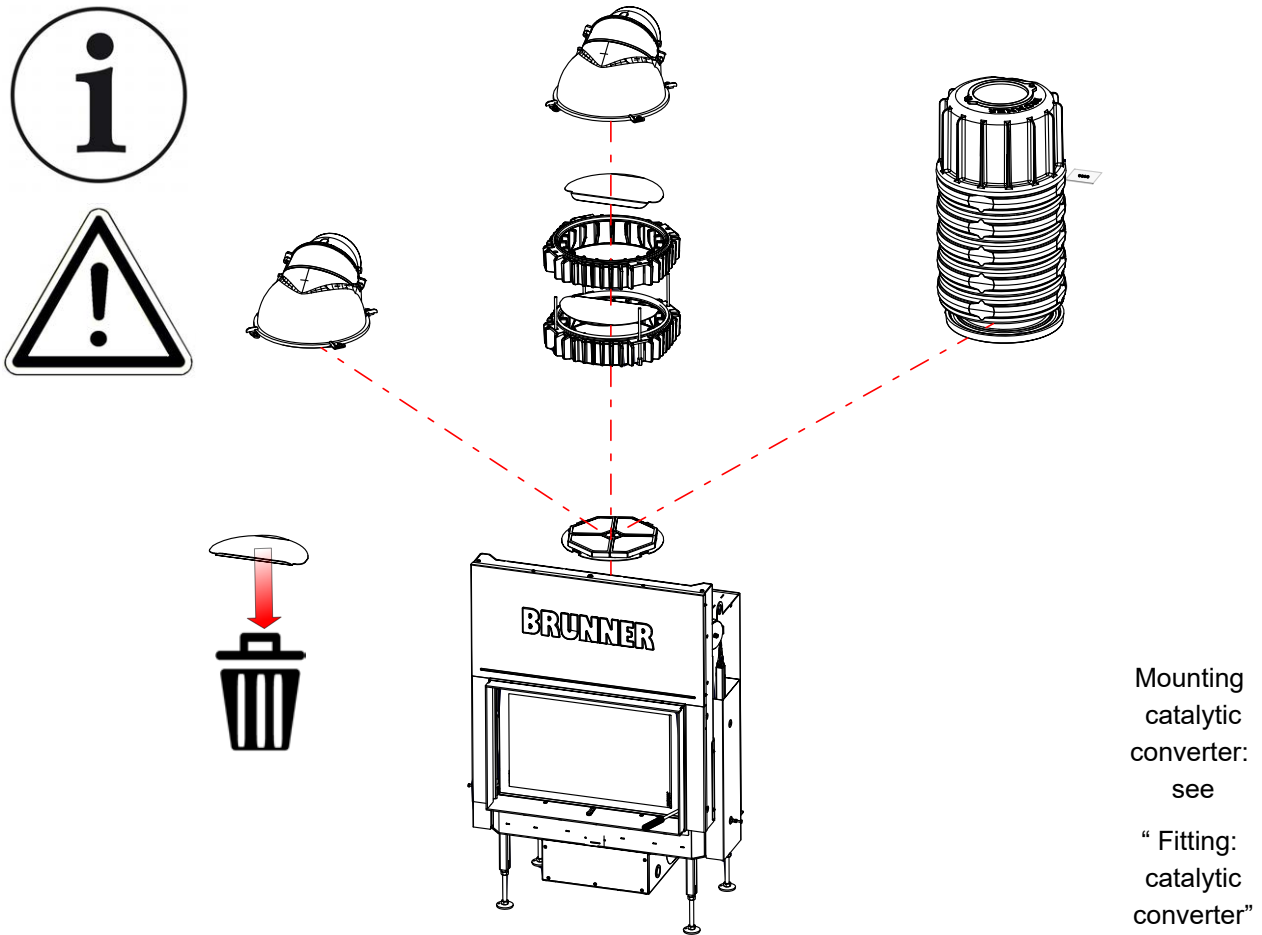

4.6.2 CONNECTION WITHOUT CATALYTIC CONVERTER

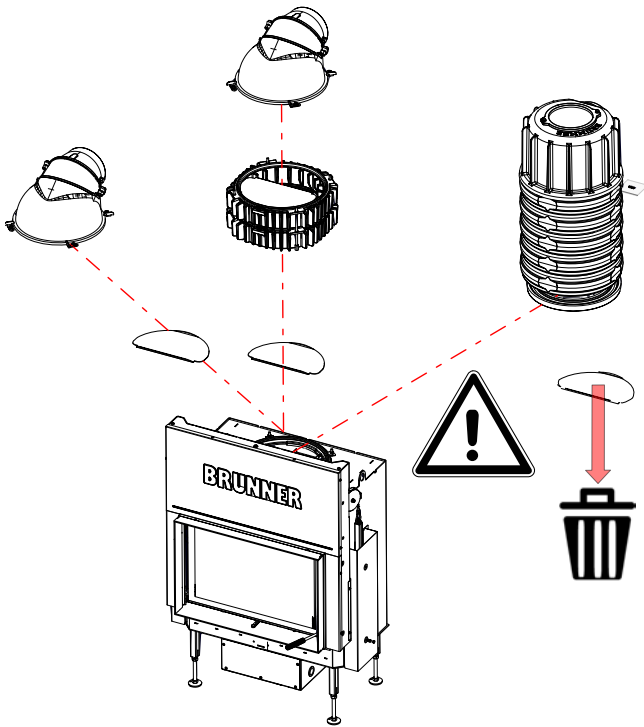

Possible variants of the connection for the outlet of flue gases

Position:
cast iron dome -
deflector plate

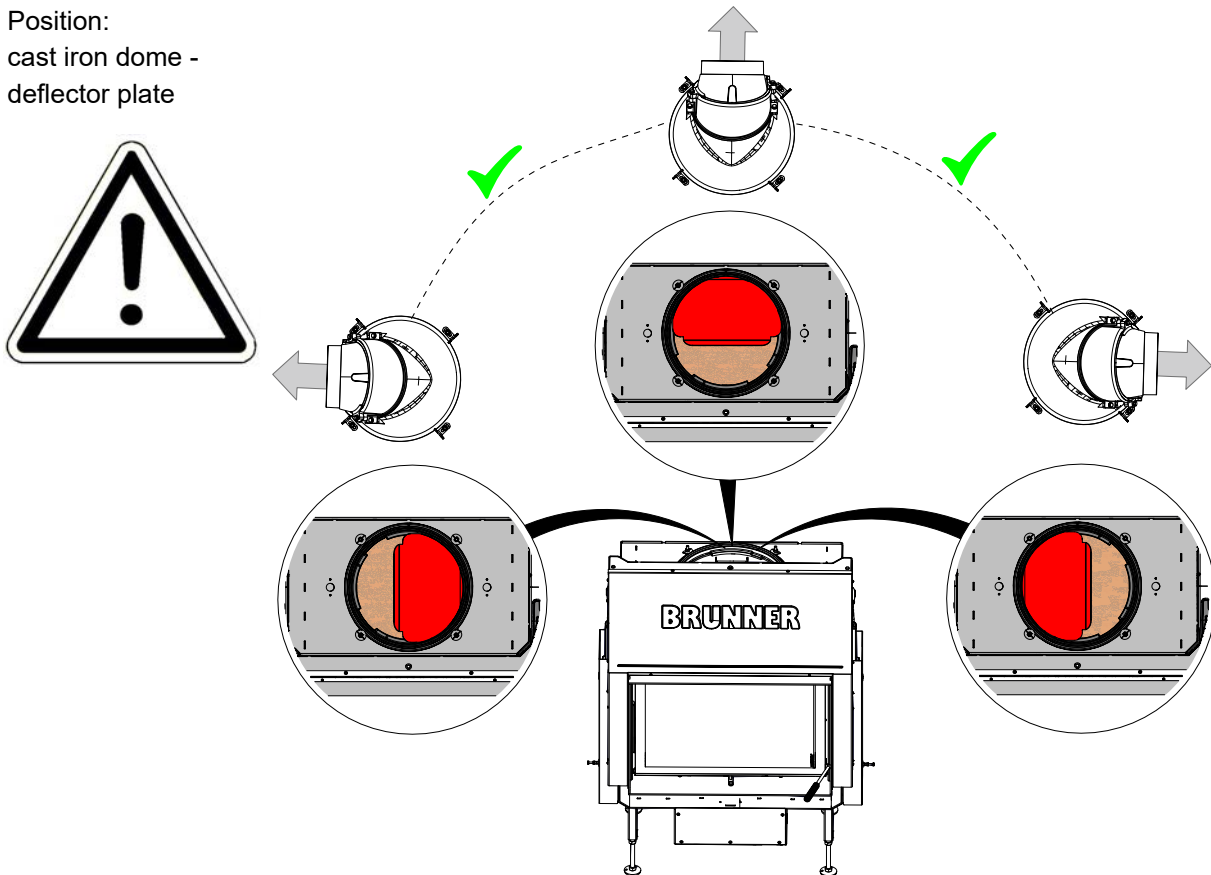

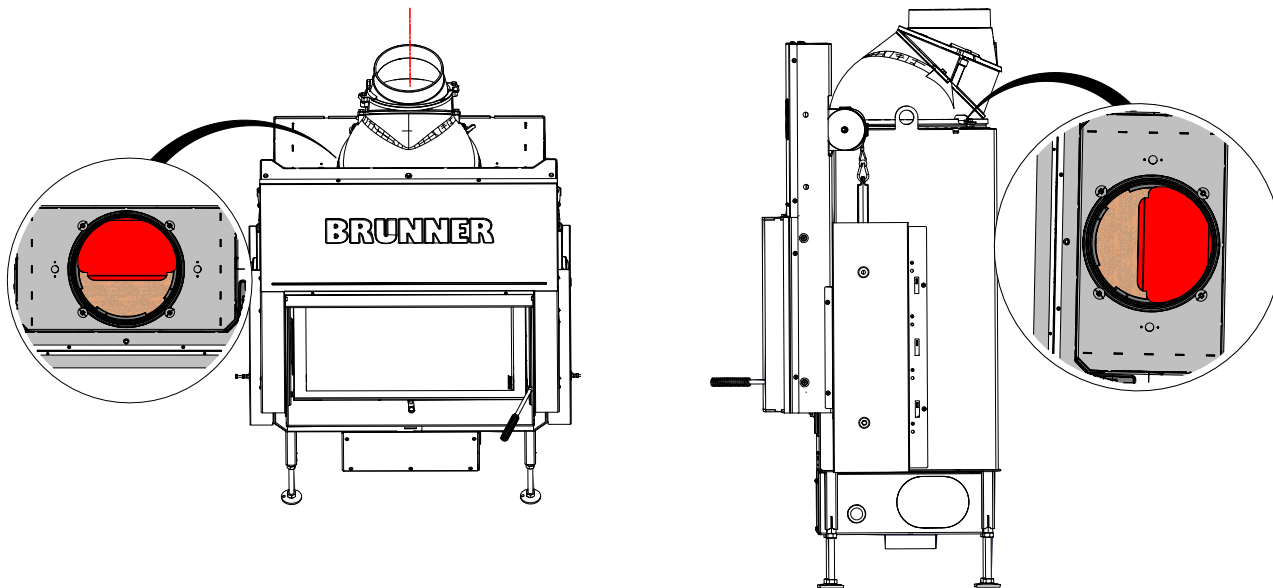
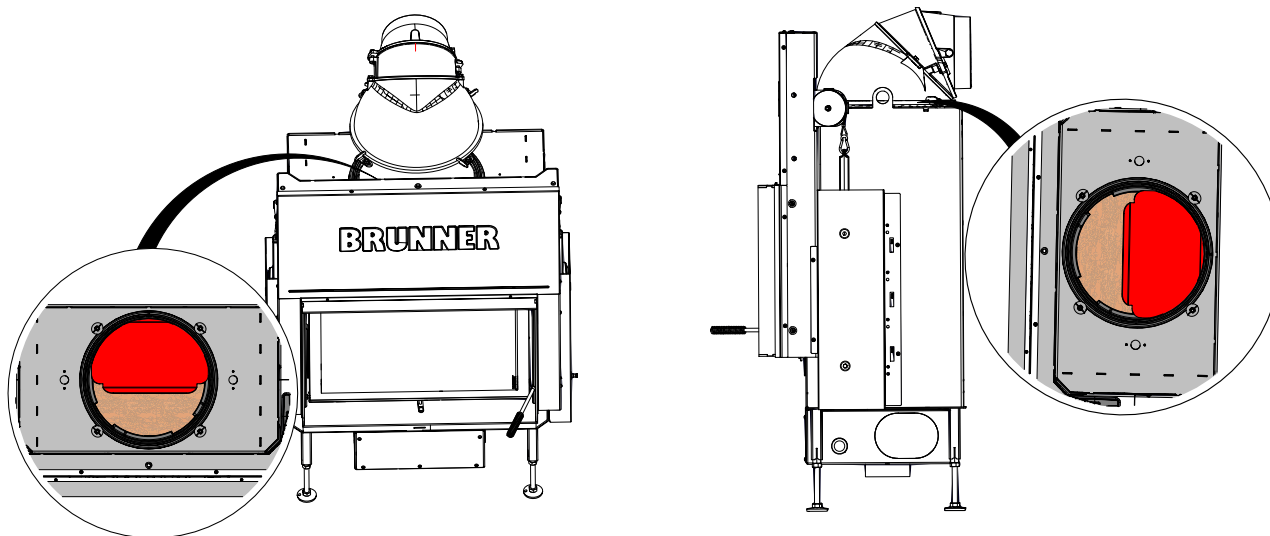
Examples for the position of the deflector plate: Connection variant for exhaust gases**1. Example A: with rotating cast iron dome - at rear - vertical****2. Example B: with rotating cast iron dome - at rear - horizontal**

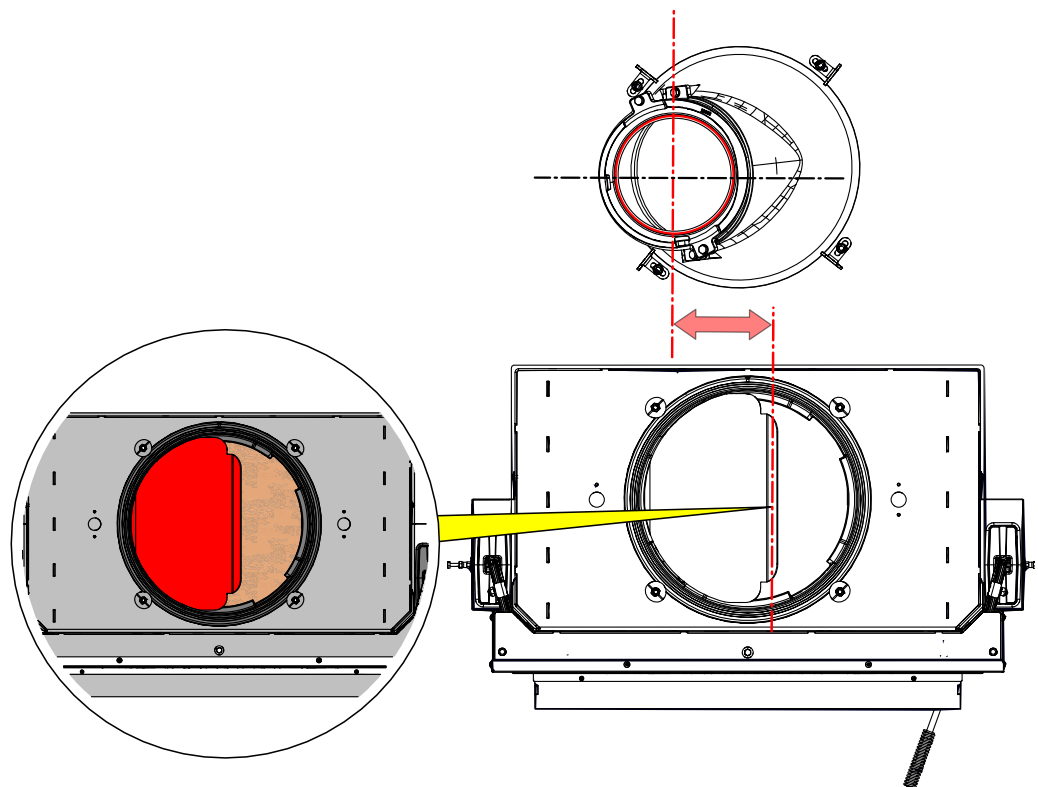
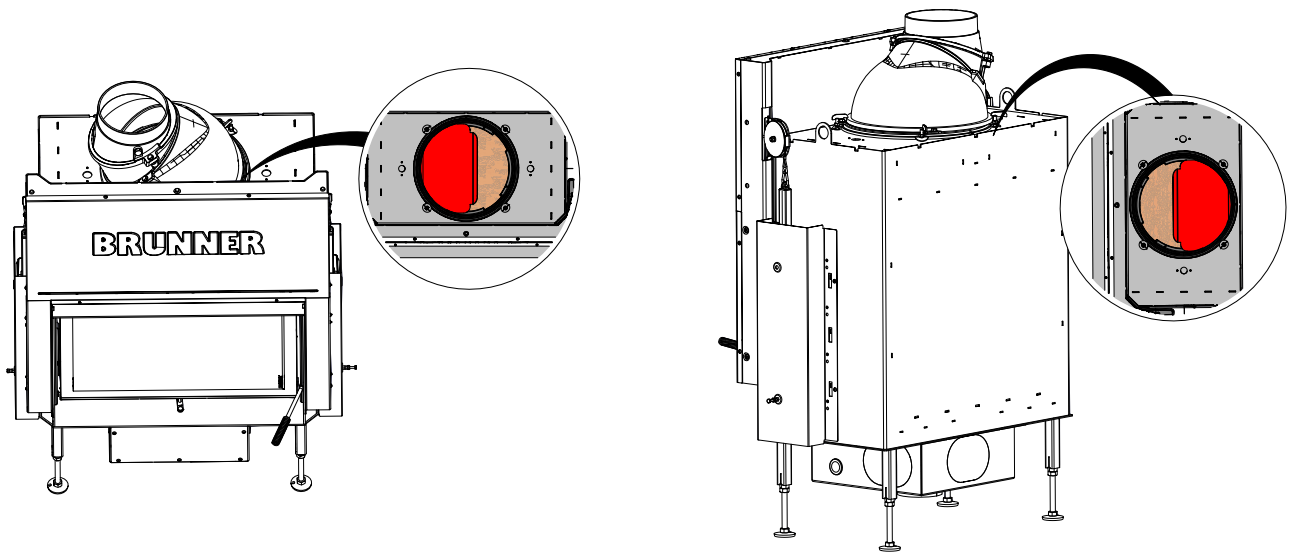
Example C: with rotating cast iron dome - left side - vertical or horizontal

Example D: with rotating cast iron dome right side vertical or horizontal

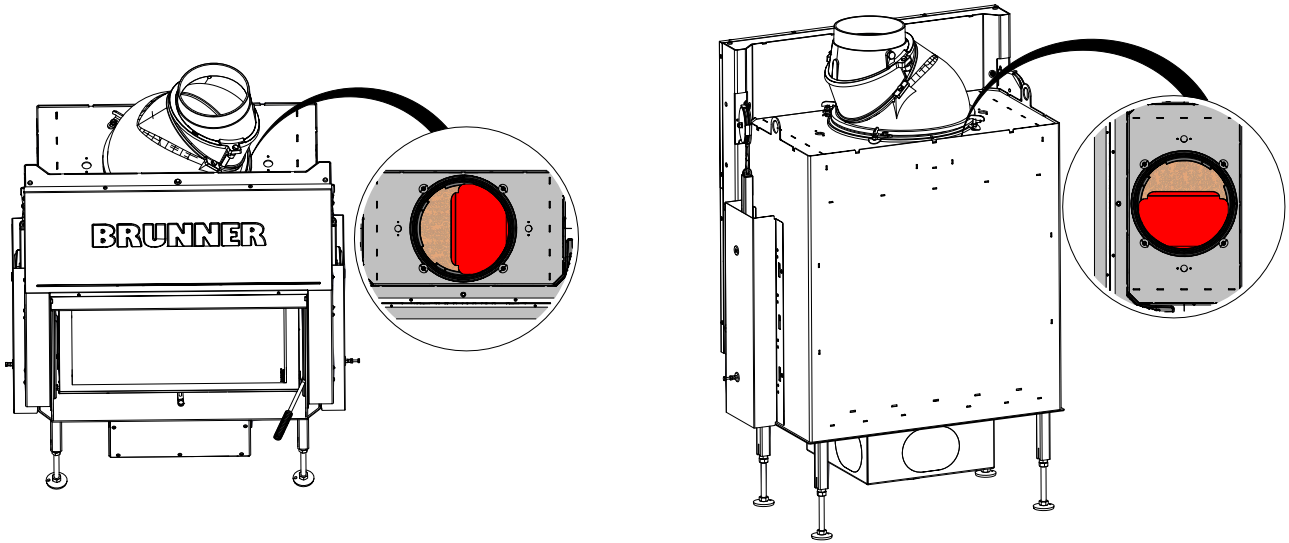

Example E: with rotating cast iron dome with heat exchanger ring - at rear - vertical or horizontal

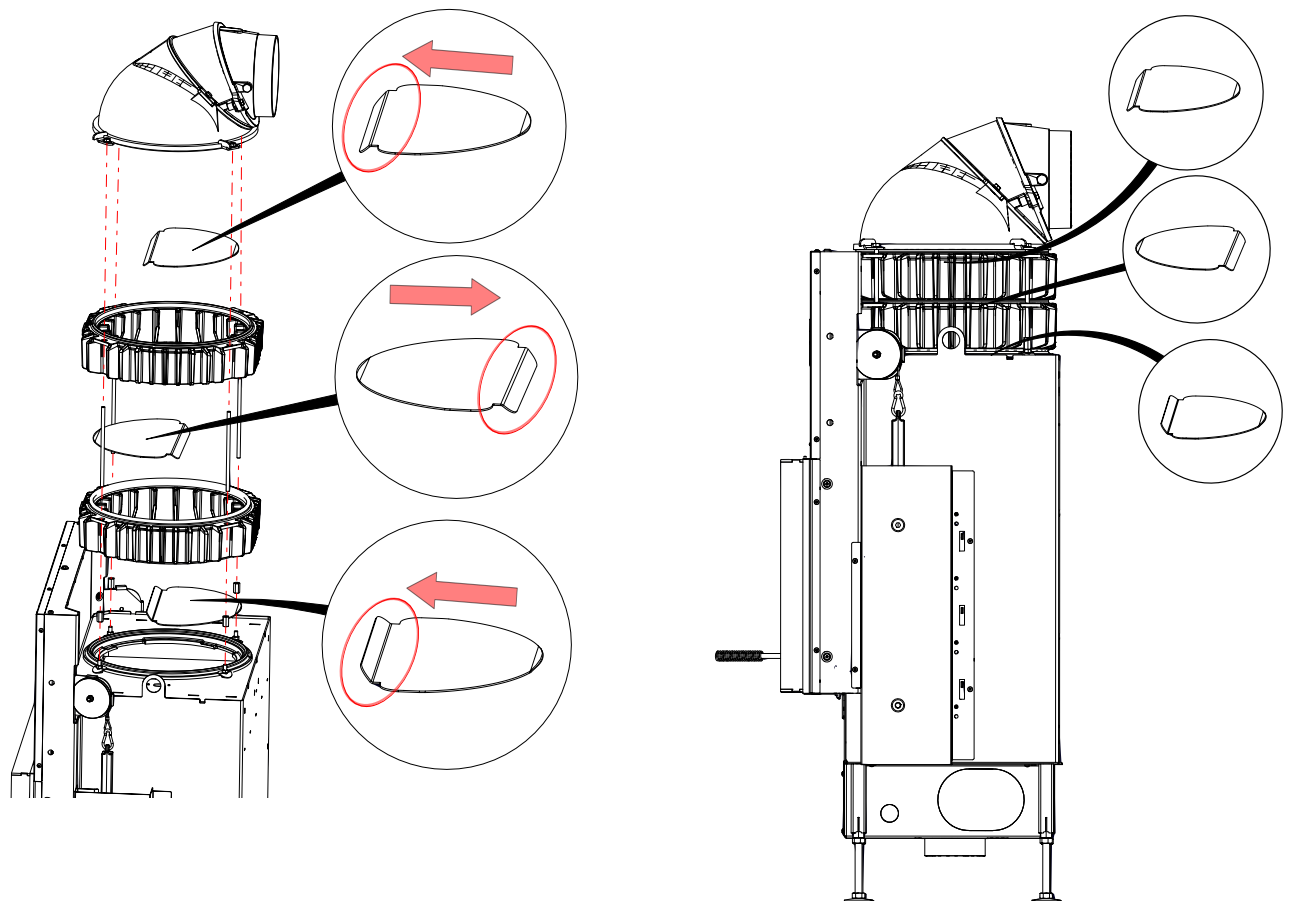

Principle of flue gas routing with heat exchanger rings

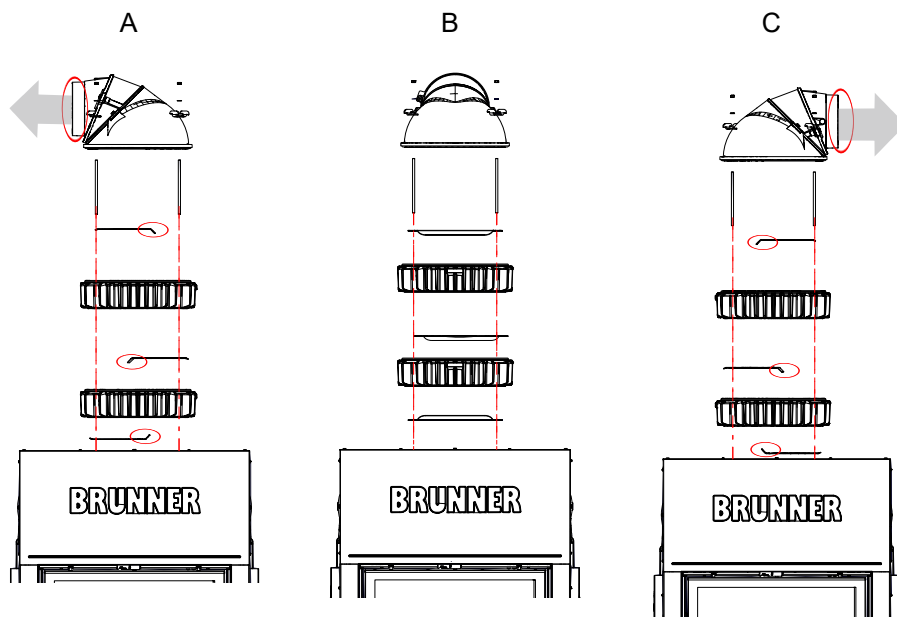
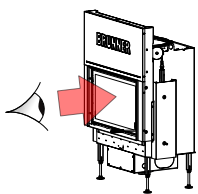
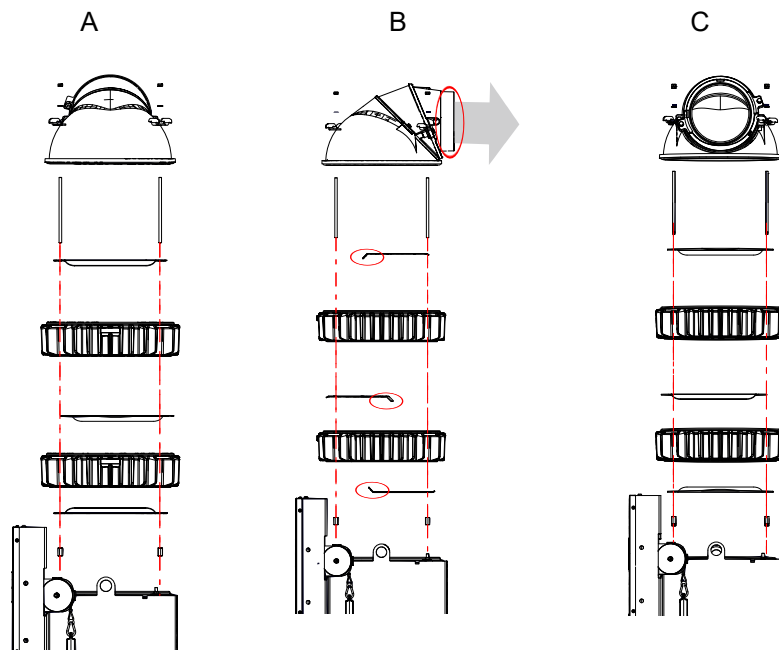
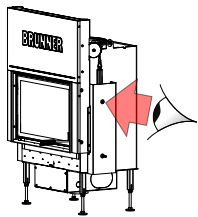
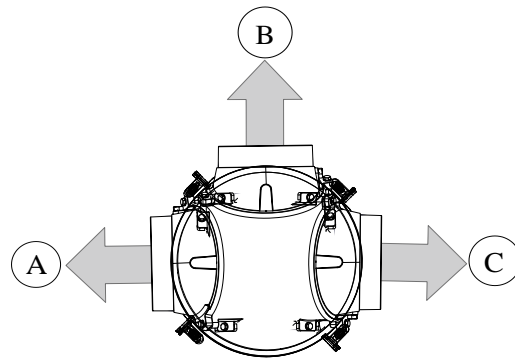

Example F: with rotating cast iron dome with cast iron heat exchanger rings - to the left vertical or horizontal

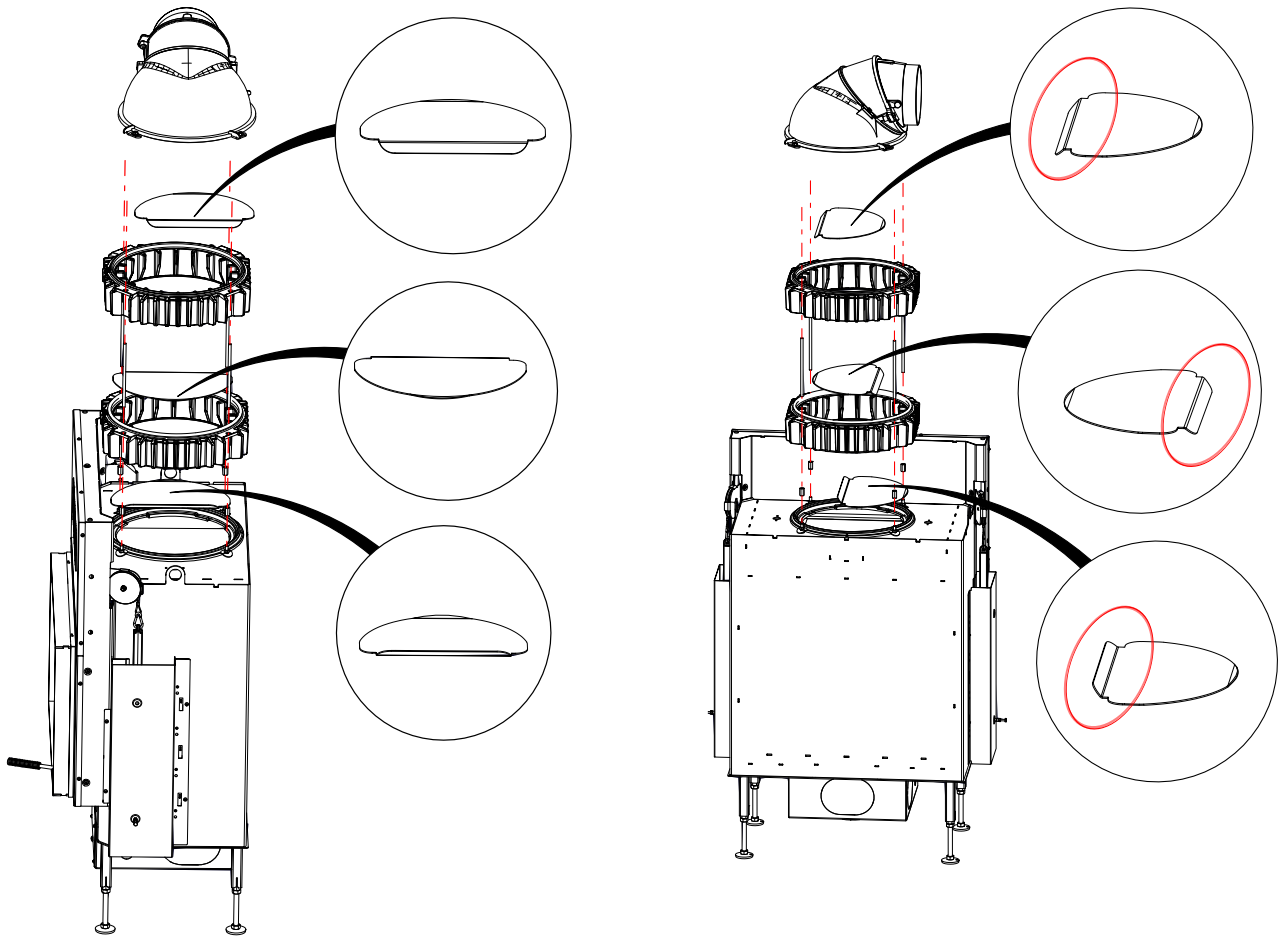

4.6.3 CAST IRON DOME

4.6.3.1 COMPONENTS CAST IRON DOME

Cast iron dome (∅ 180 mm = D004186 ; ∅ 200 mm = 10087)

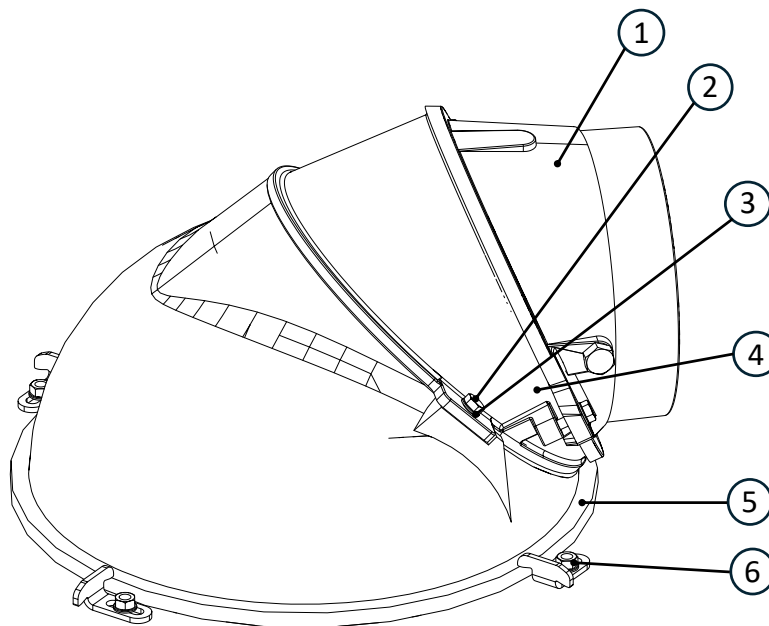

| Position | Designation | Variant | Art.-Nr. | pcs |
|----------|--------------------------|----------|----------|-----|
| 1 | Connection bend | ∅ 180 mm | D004188 | 1 |
| | | ∅ 200 mm | 10088 | 1 |
| 2 | Hexagon head screw M8x25 | | 00683 | 4 |
| 3 | Washer | | 800267 | 4 |
| 4 | Aufsatzbogen | | 08201 | 1 |
| 5 | Dome | | 08200 | 1 |
| 6 | Accessory pack | | N008057 | 1 |

4.6.3.2 CAST IRON DOME

vertical outlet

horizontal outlet

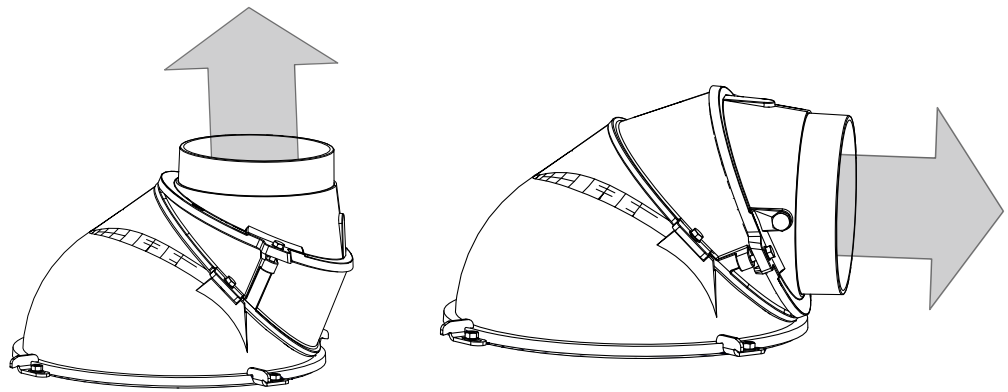

INFO modification: see enclosed sheet - cast iron dome

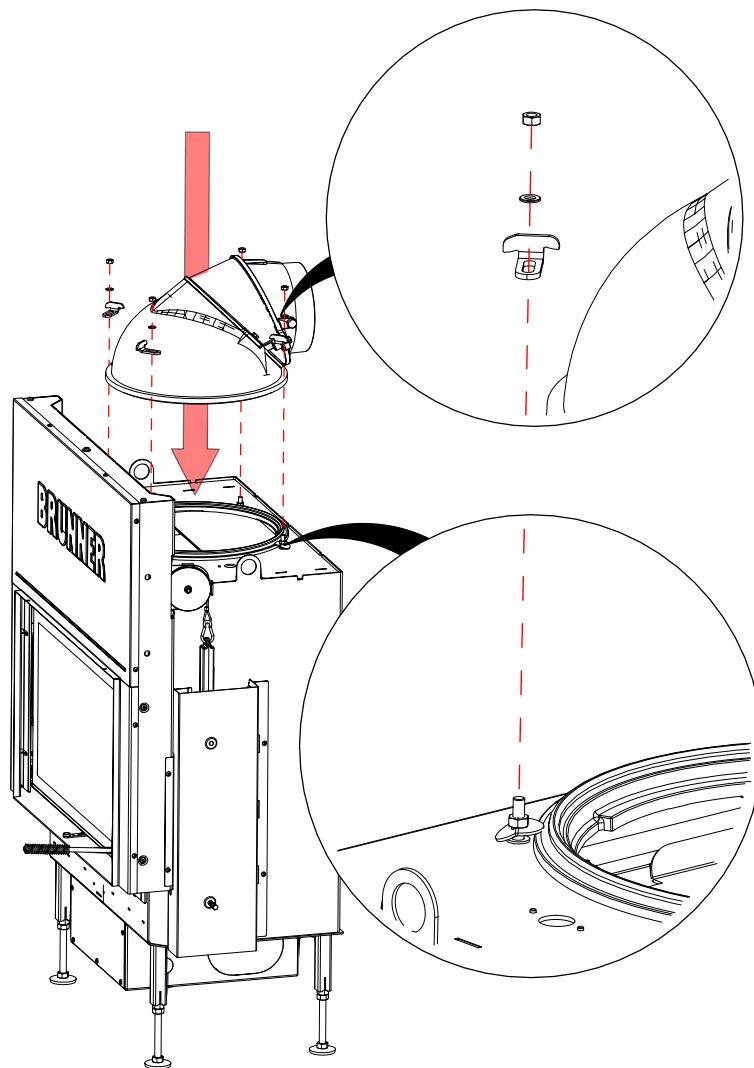

Im. 7: Summarised information

Workflow:

1

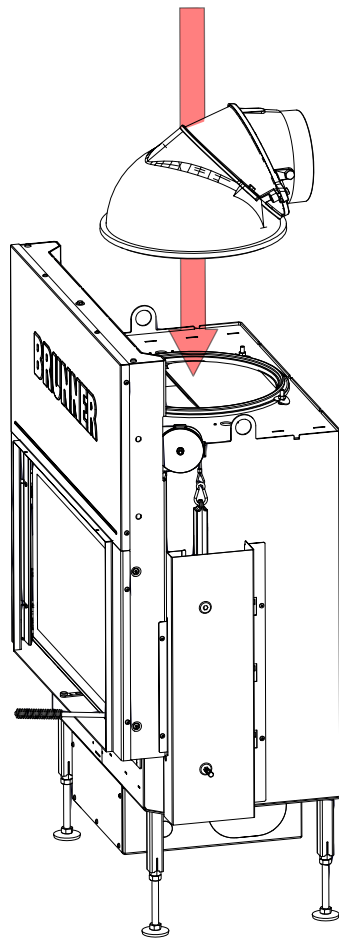

2

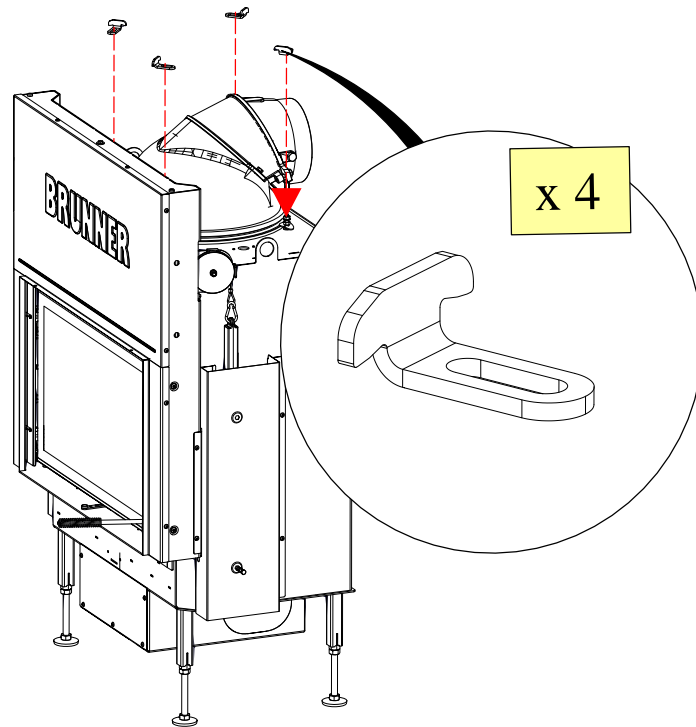

3

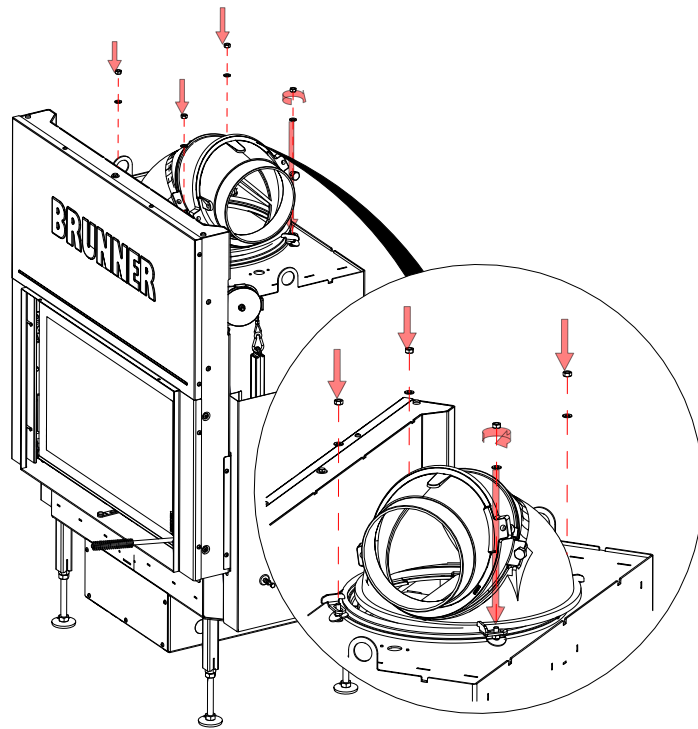

4

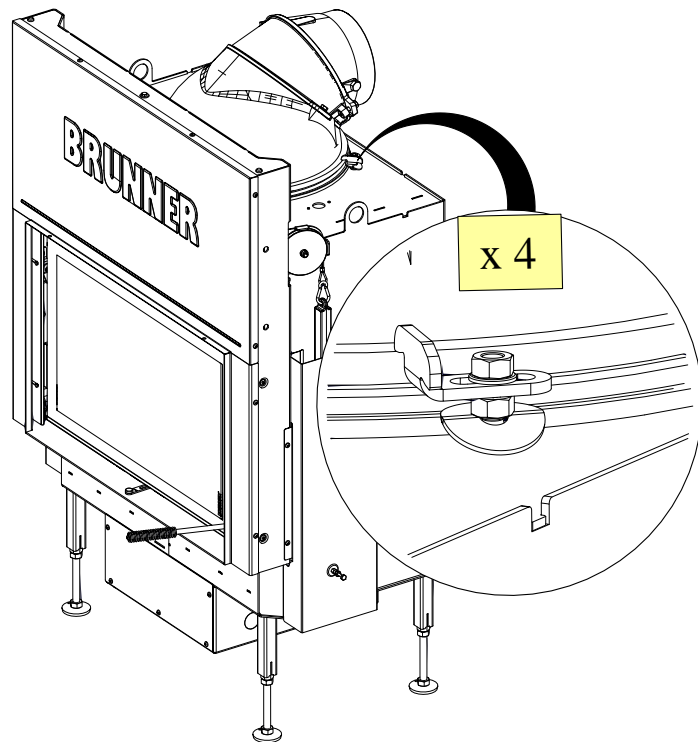

4.6.3.3 ADDITIONAL OPTION : HEAT EXCHANGER RINGS

4.6.3.3.1 COMPONENTS HEAT EXCHANGER RINGS

SET Heat exchanger rings (R015006-04)

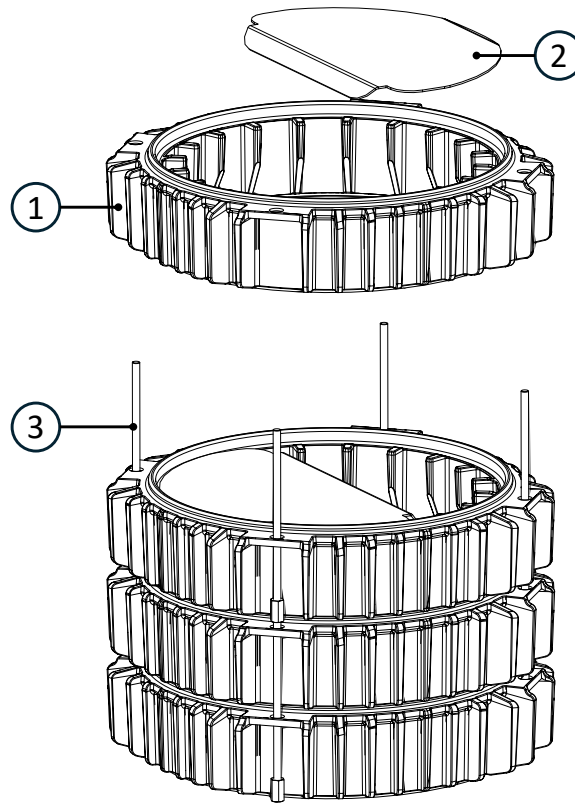

| Position | Designation | Art.-Nr. | Pcs. |
|----------|-------------------------------|----------|------|
| 1 | Cast iron heat exchanger ring | R015002 | 4 |
| 2 | Heat exchanger deflector | R015003 | 4 |
| 3 | Threaded rod M8x200 | R015008 | 2 |

4.6.3.3.2 HEAT EXCHANGER RINGS

Summarised information:

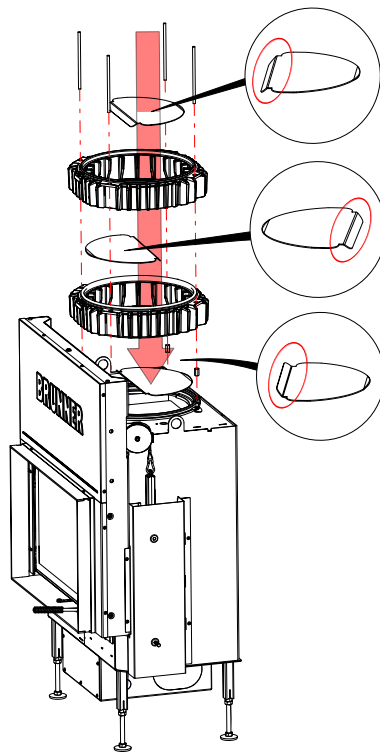

Workflow:

1

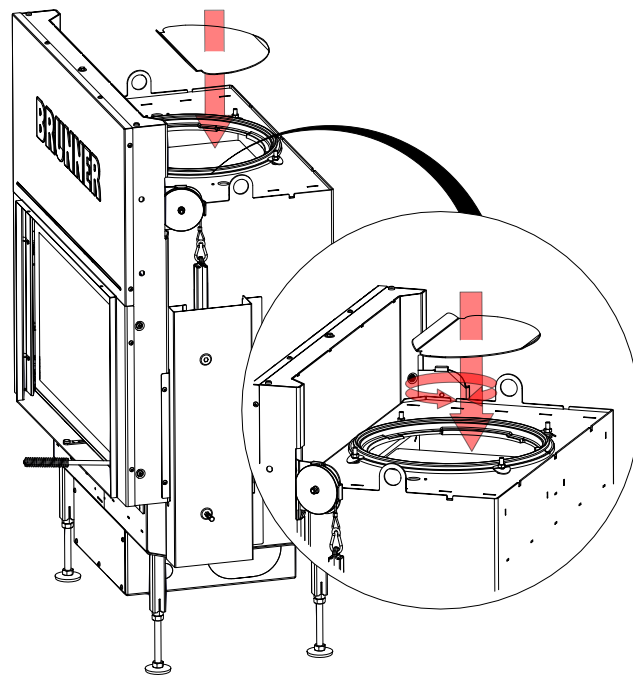

2

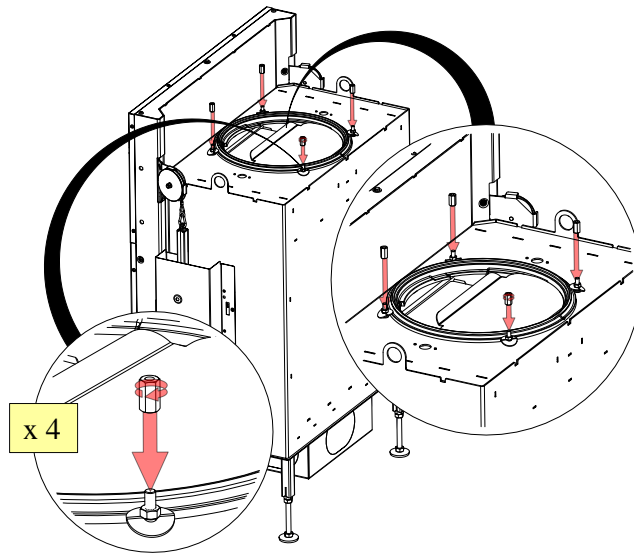

3

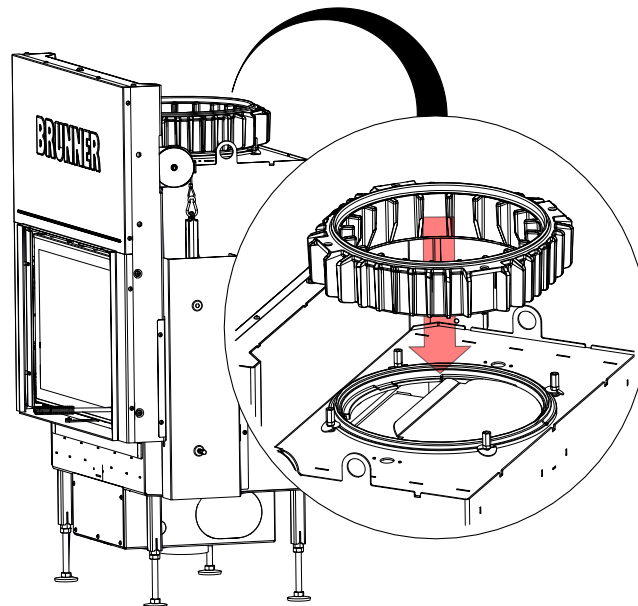

4

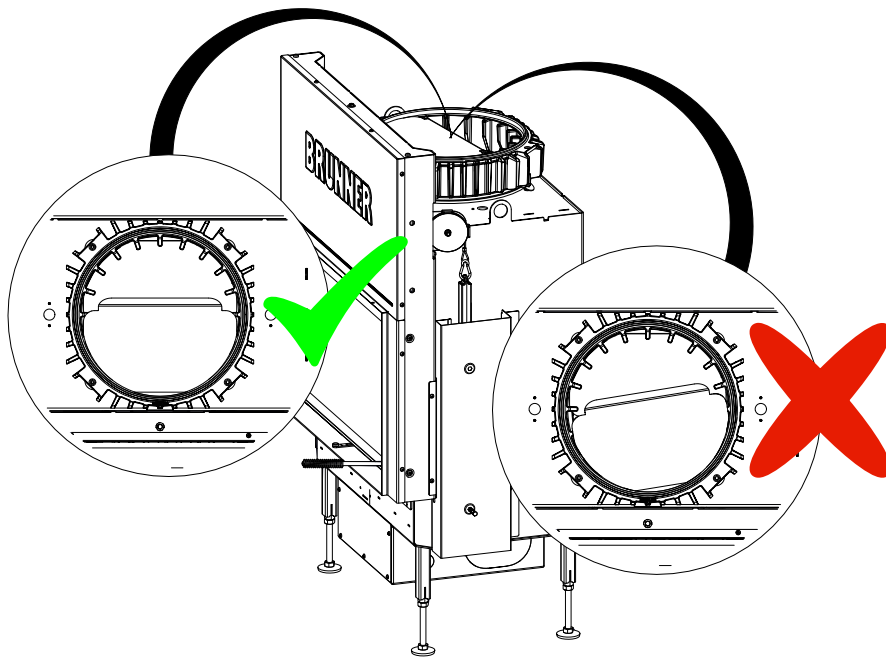
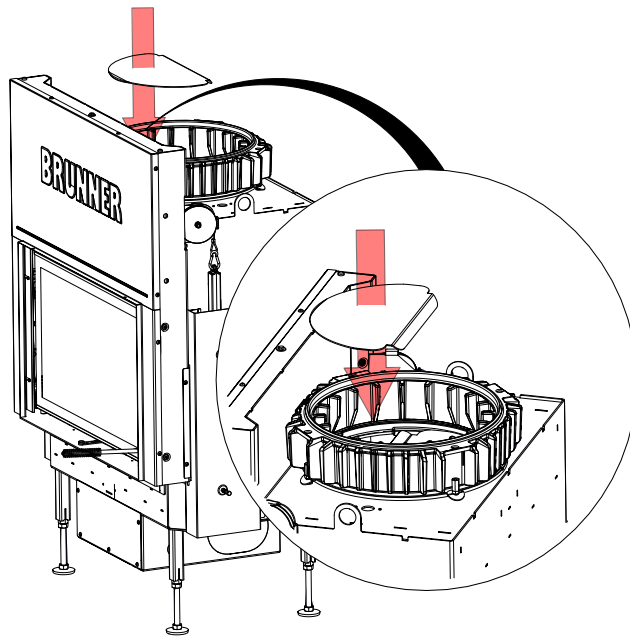

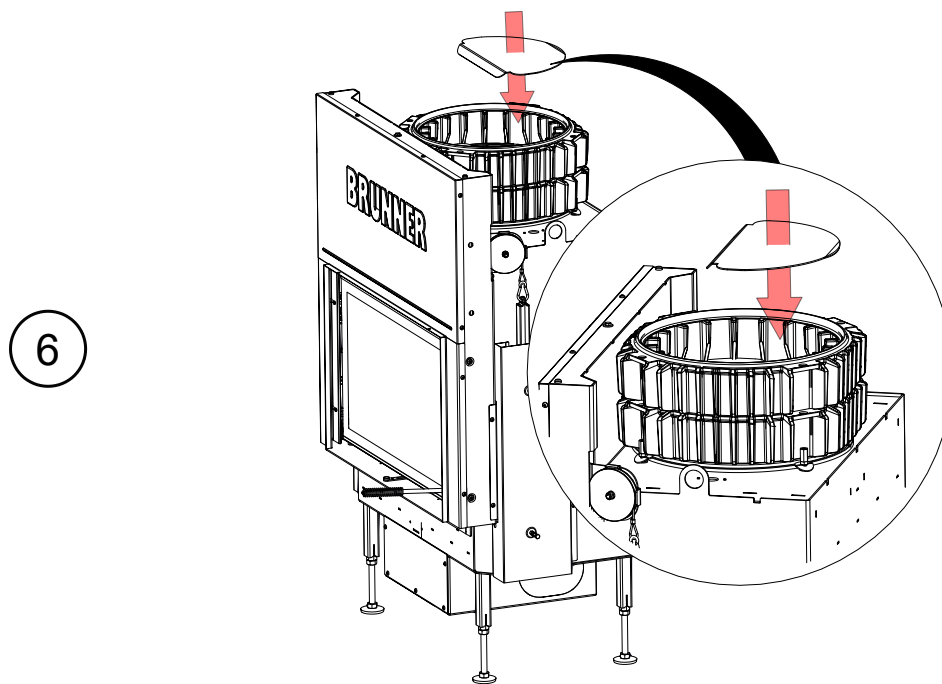
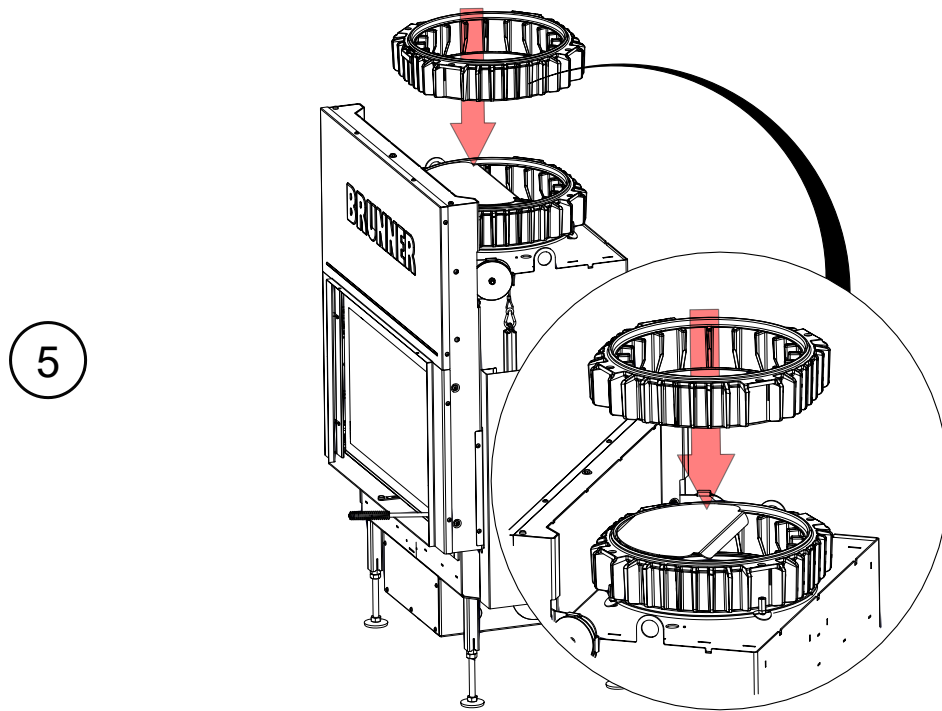

7

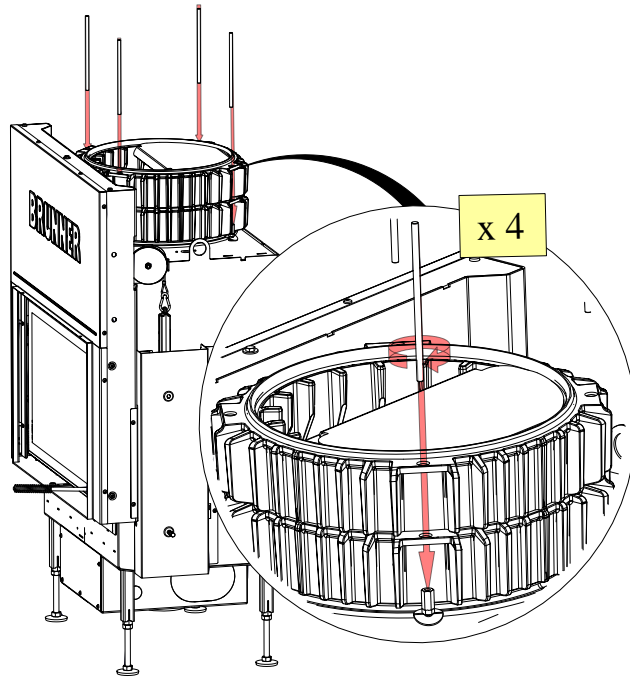

8

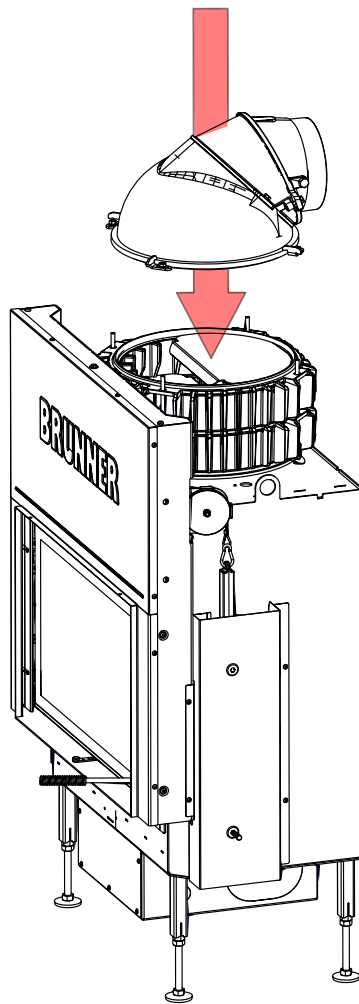

Thereafter: see "Cast iron dome"

4.6.4 MAS

4.6.4.1 COMPONENTS MAS MODULAR TOP-MOUNT STORAGE SET 440

MAS modular top-mount storage SET 440 (SET211444)

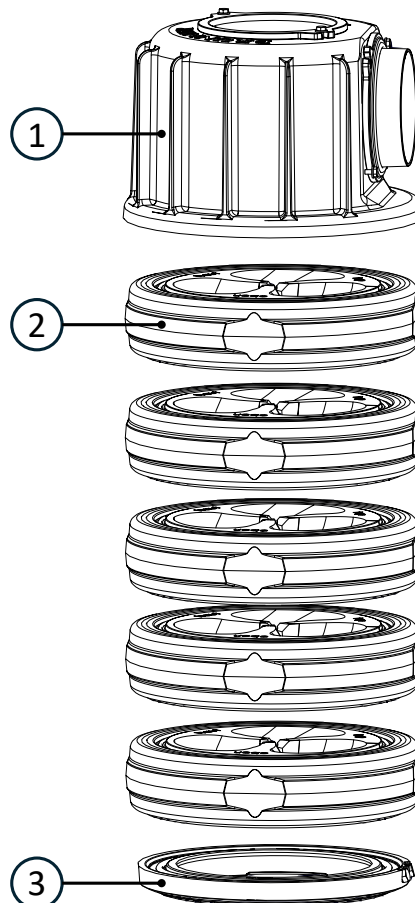

| Position | Designation | Art.-Nr. | Pcs. |
|----------|---|------------|------|
| 1 | Cast iron dome \varnothing 180 mm | R009095-01 | 1 |
| 2 | MAS 440 accumulation stone double-layered | R009042 | 5 |
| 3 | Mounting ring | 10077 | 1 |

4.6.4.2 HEAT EXCHANGER MAS

Summarised information:

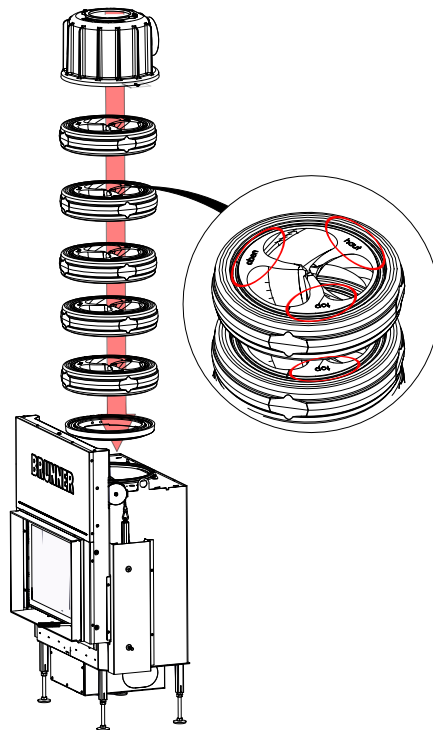

Workflow:

1

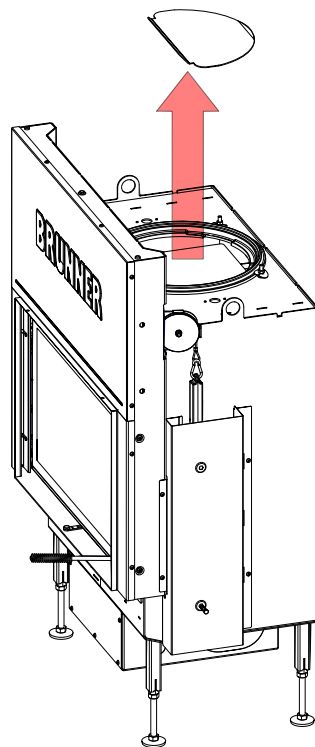

2

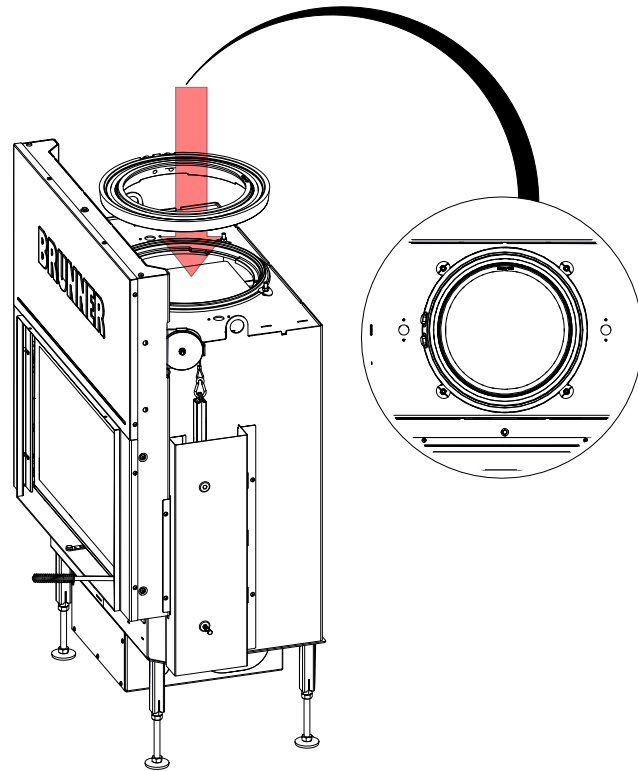

3

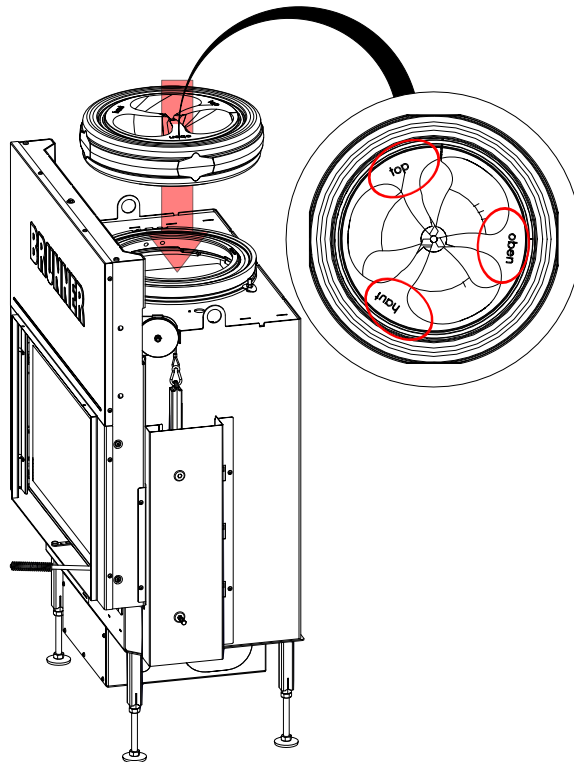

4

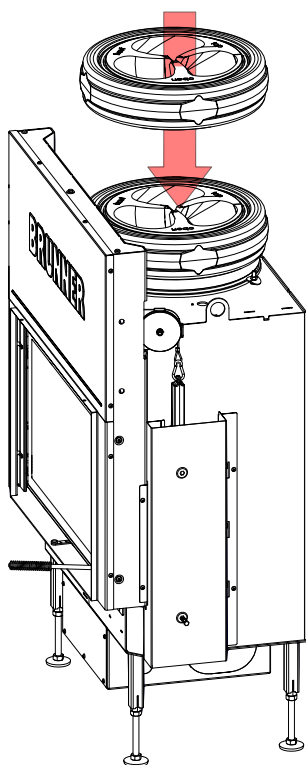

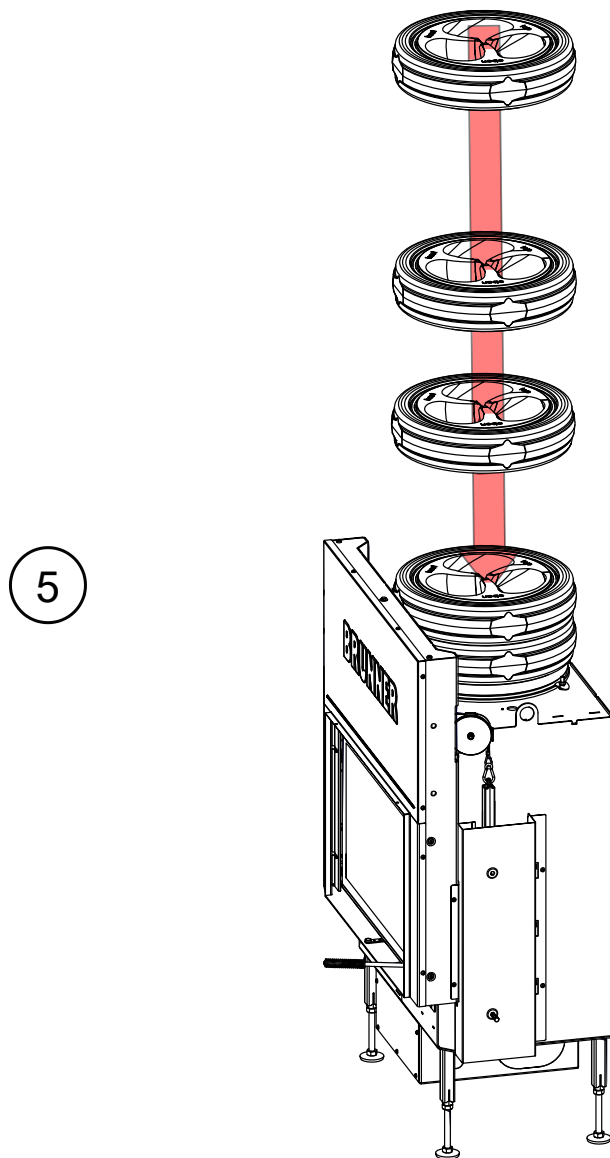

6

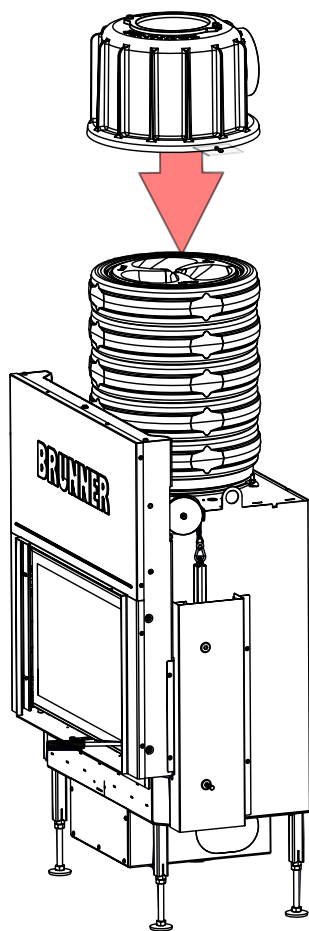

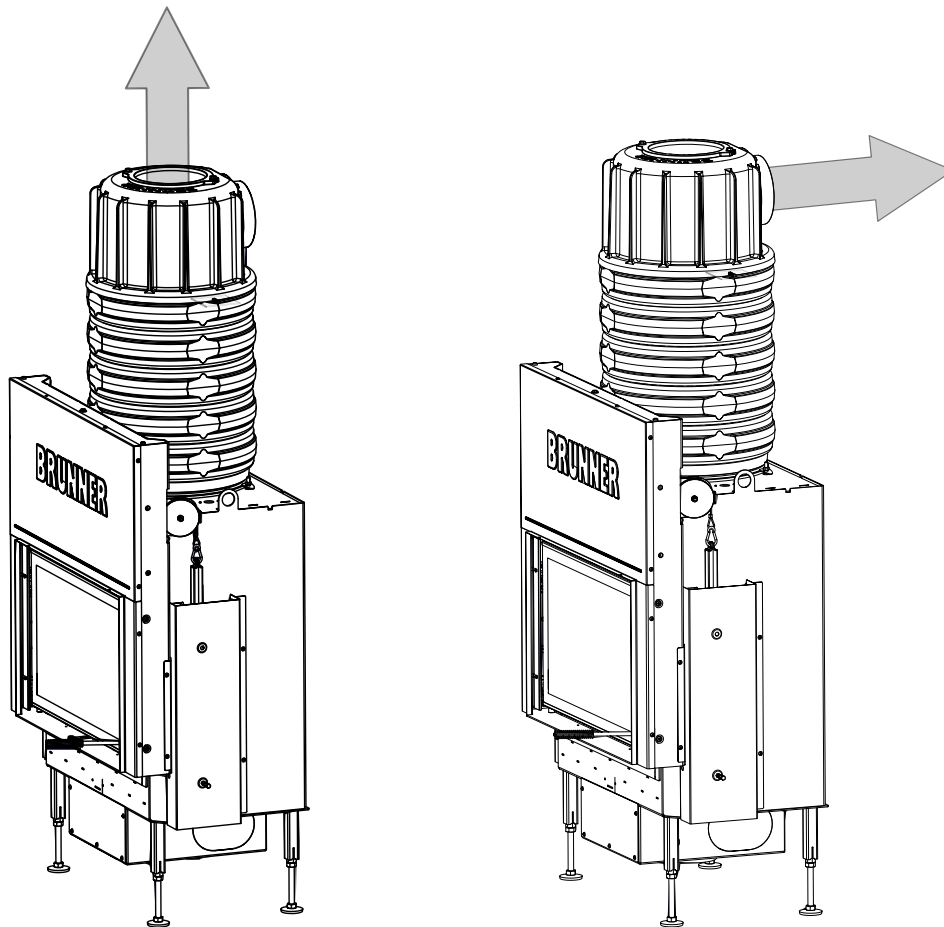

NOTICE

Ensure correct position after fitting the cast iron dome!

During installation, the cast dome can shift so that it no longer sits correctly aligned on the mounting ring.

- ▶ Check with light test: Illuminate the combustion chamber to make any gaps between the mounting ring and the cast iron dome visible.

4.7 VARIANT: EOS

4.7.1 BOTTOM COVER AIR BOX EOS

4.7.1.1 COMPONENTS EOS

BG Bottom cover Air box small, EOS (HK000064)

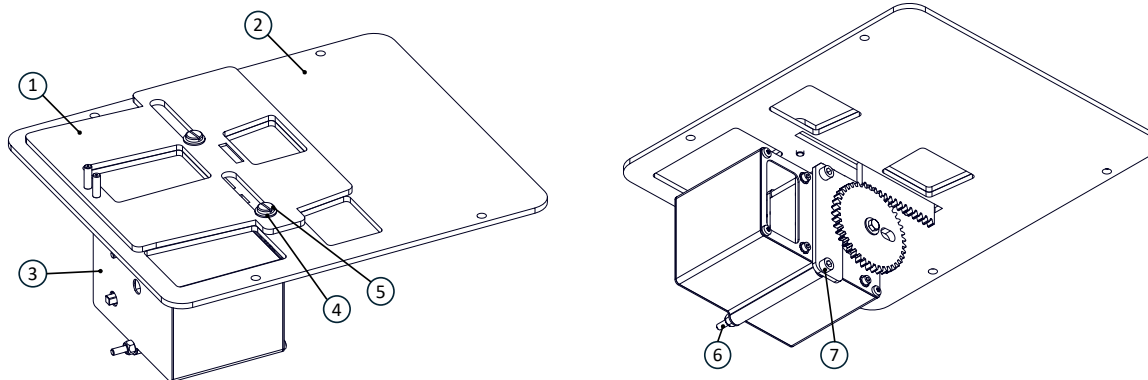

| Position | Designation | Art.-Nr. | pcs |
|----------|-----------------------------------|----------|-----|
| 1 | Air slide plate small EOS | HK000232 | 1 |
| 2 | BG Bottom cover Air box small EOS | HK000219 | 1 |
| 3 | BG Servomotor EOS with Gear wheel | N003157 | 1 |
| 4 | Collar bushing | I007337 | 2 |
| 5 | Flat head screw (M5x6) | 800461 | 2 |
| 6 | hexagon nut with Clamping part | 800155 | 2 |
| 7 | Cylinder head screw (M5x100) | 800035 | 2 |

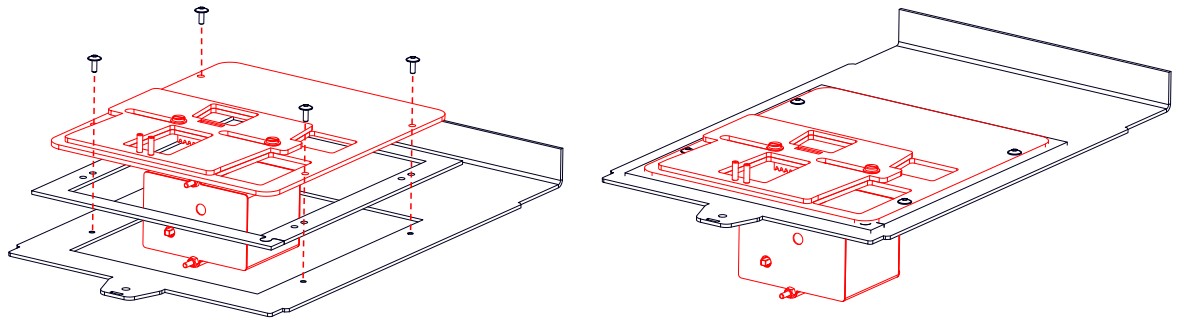
4.7.1.2 FITTING: EOS

1

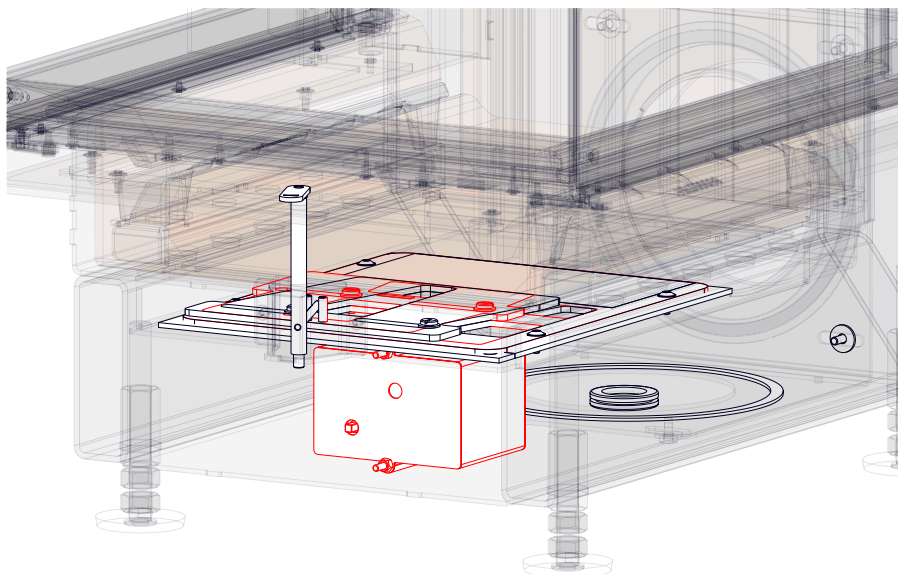
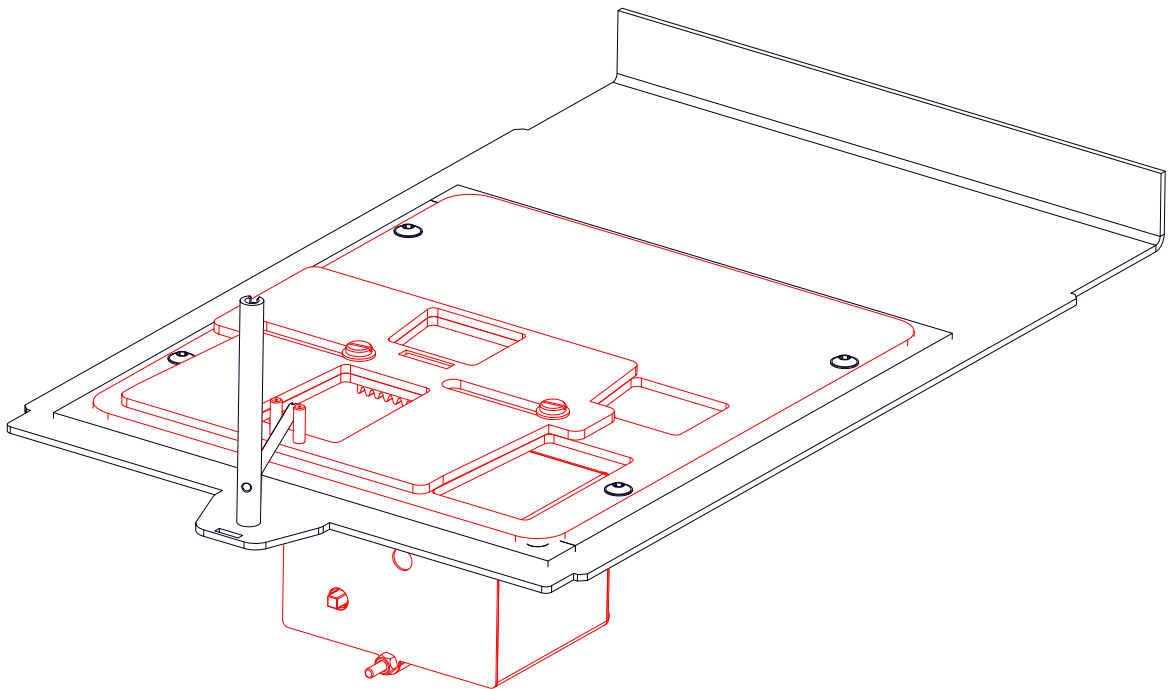

4.7.1.3 MEMBRANE FEED-THROUGH

Membrane feed-through (901248-01)

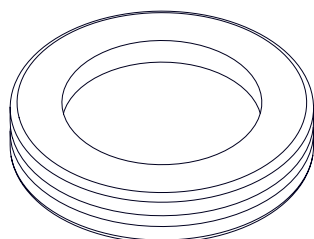

Position

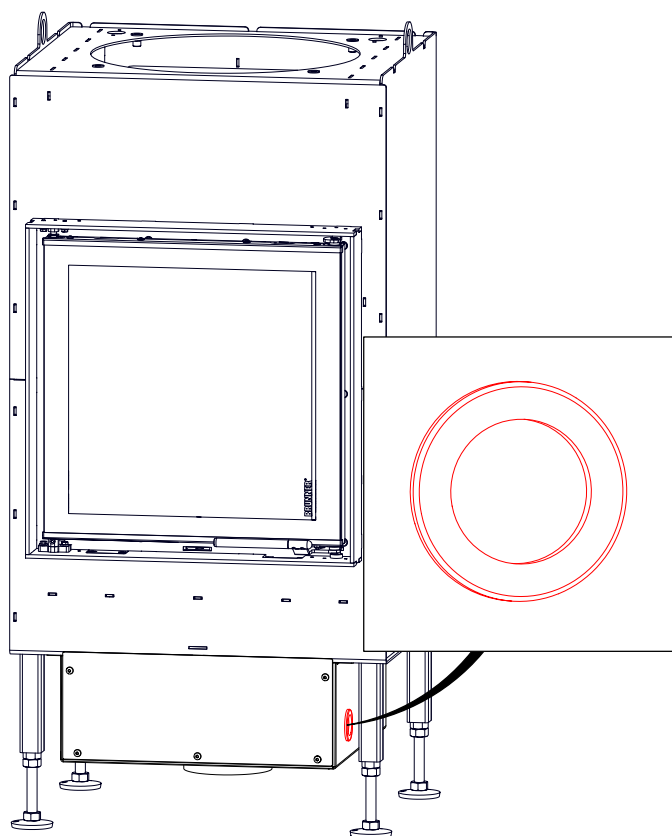

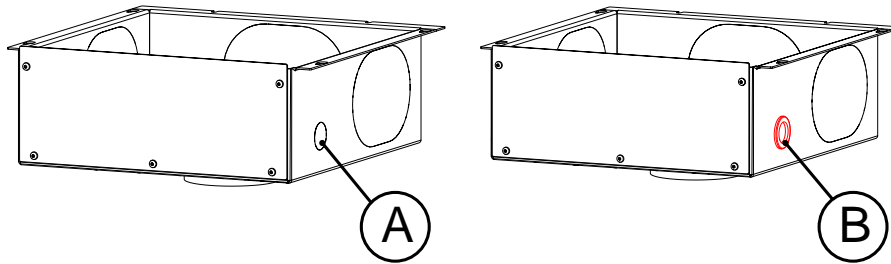

A = BKH

B = BKH with EOS

4.7.1.4 AIR POSITION INDICATOR FLAT

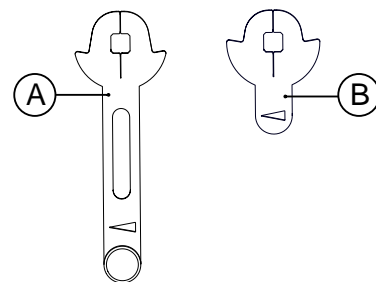
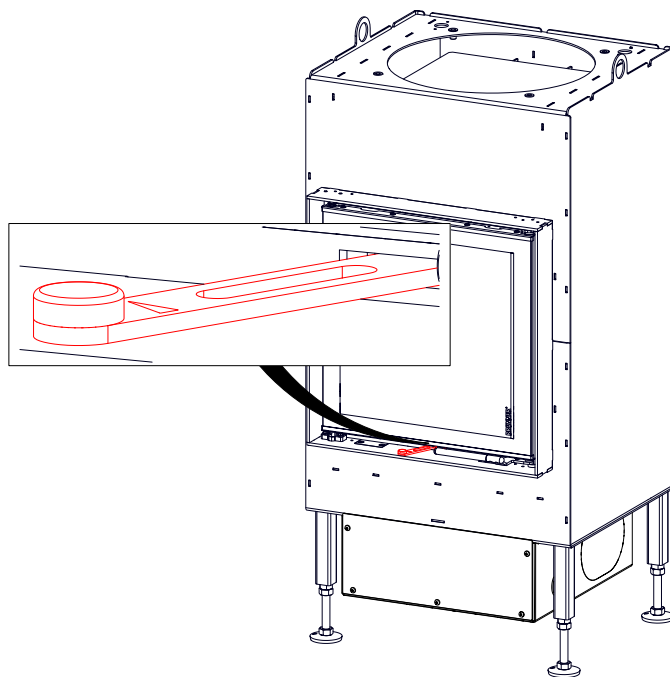

A = BKH flat

B = BKH flat with EOS

4.7.2 THERMOCOUPLE

4.7.2.1 COMPONENTS THERMOCOUPLE

BG Thermocouple with Retaining plate (HK000095)

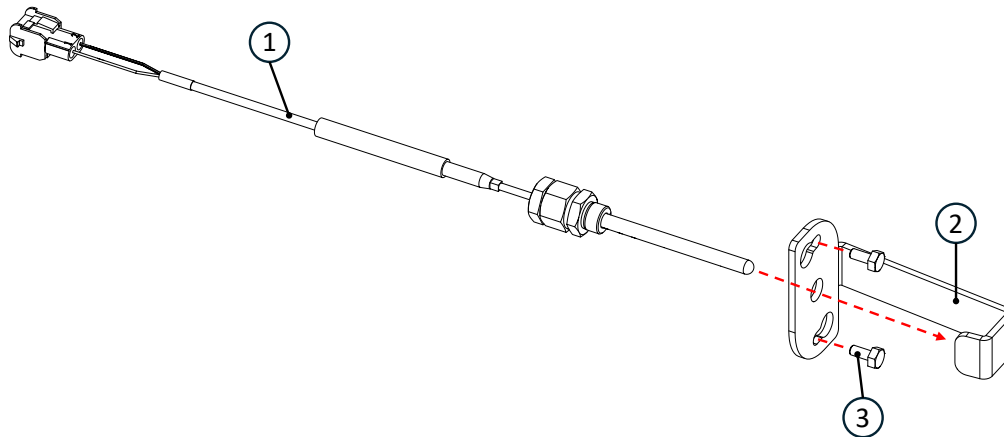

| Position | Designation | Art.-Nr. | Pcs. |
|----------|------------------------------|----------|------|
| 1 | BG Thermocouple | 10992.1 | 1 |
| 2 | Thermocouple Retaining plate | HK000216 | 1 |
| 3 | Hexagon head screw (M5x10) | 02531 | 2 |

4.7.2.2 FITTING: THERMOCOUPLE

Position

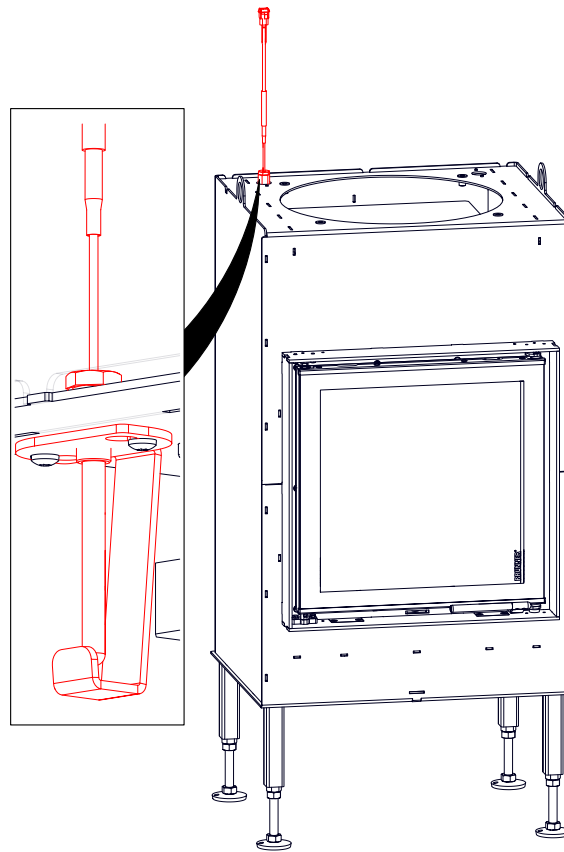

Workflow

1

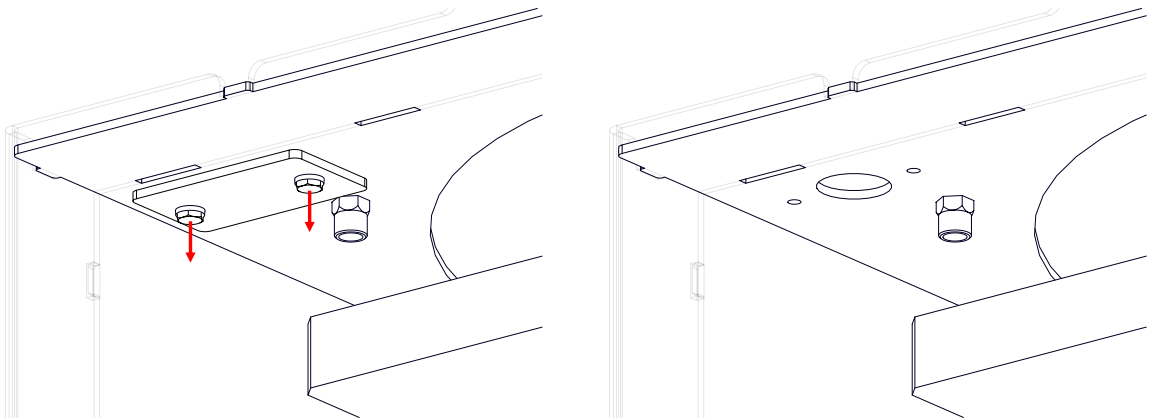

2

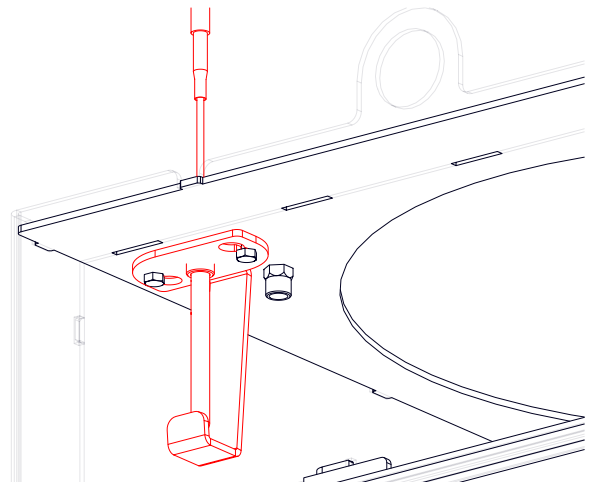
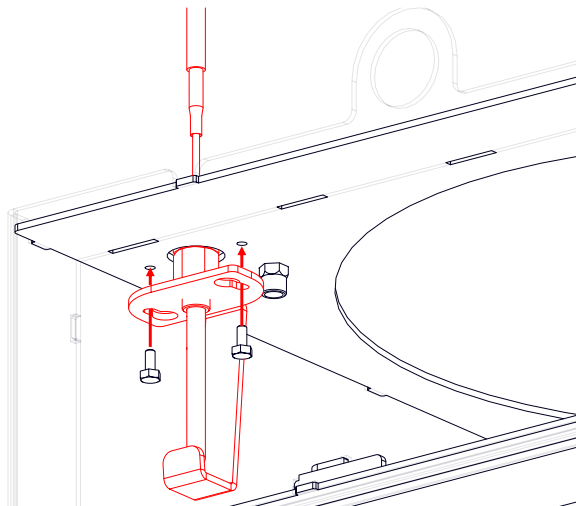

Variant: Ther-
mocouple
right side

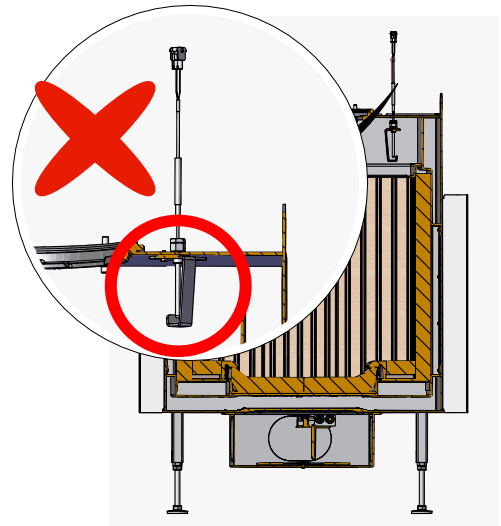
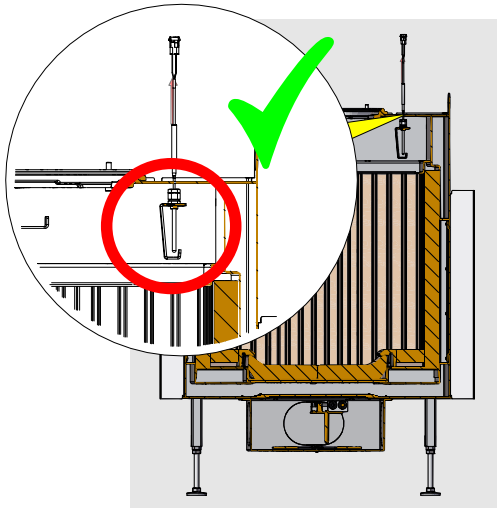

Variant: Ther-
mocouple
left side

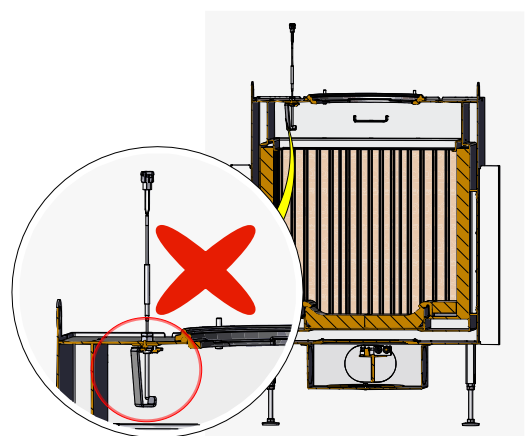
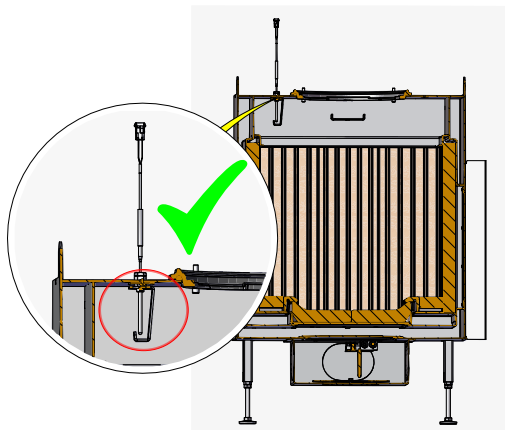

4.7.3 DOOR CONTACT SWITCH

4.7.3.1 COMPONENTS DOOR CONTACT SWITCH

Door contact switch (E011001)

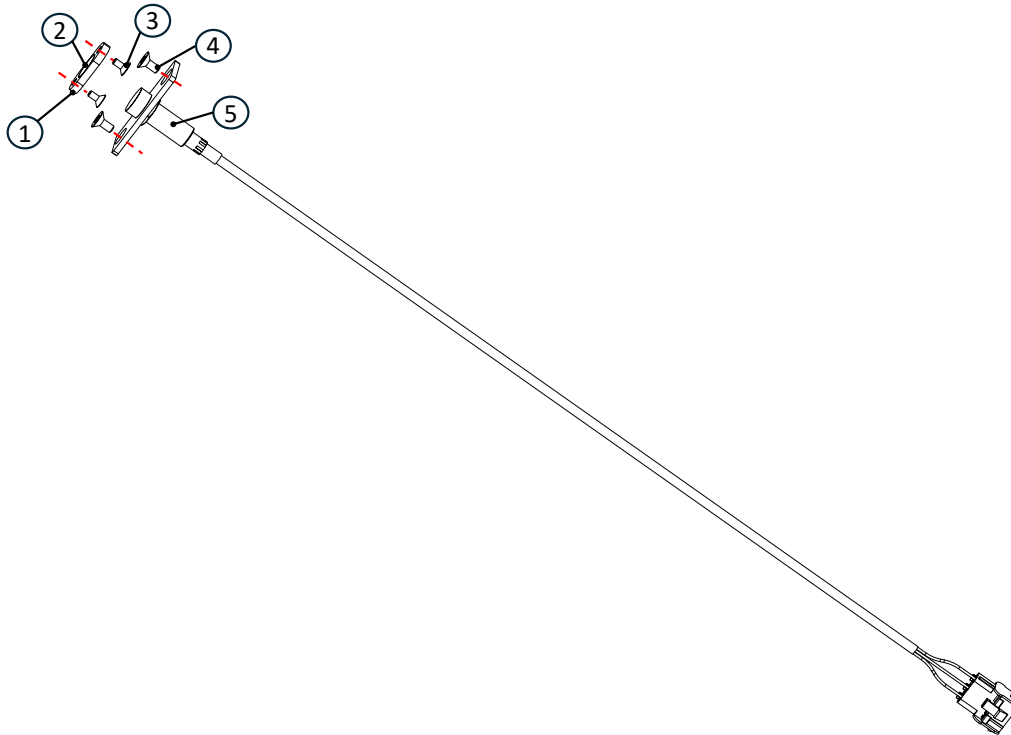

| Position | Designation | Art.-Nr. | Pcs. |
|----------|---------------------------|----------|------|
| 1 | Retaining plate Magnet | E011011 | 1 |
| 2 | Magnet | 903324 | 1 |
| 3 | Countersunk screw (M4x8) | 800063 | 2 |
| 4 | Countersunk screw (M5x10) | 800184 | 2 |
| 5 | BG Door contact switch | E011003 | 1 |

4.7.3.2 FITTING: DOOR CONTACT SWITCH

Position

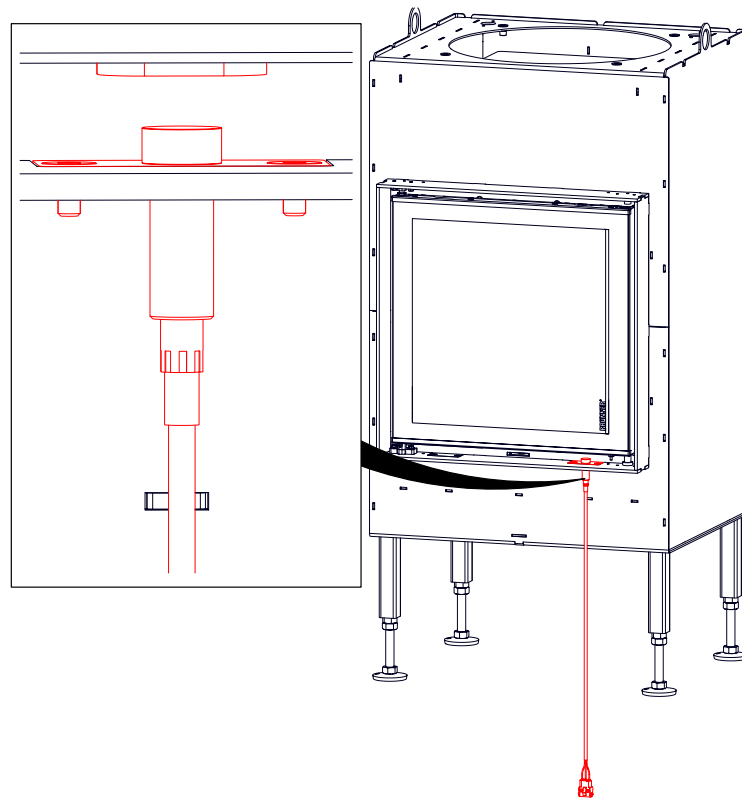

Workflow

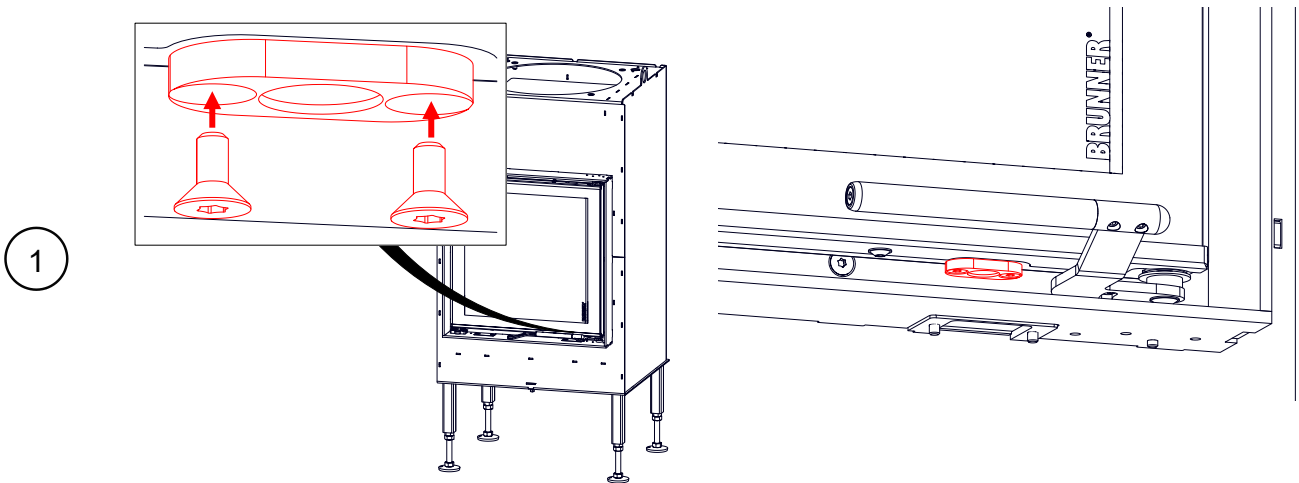

2

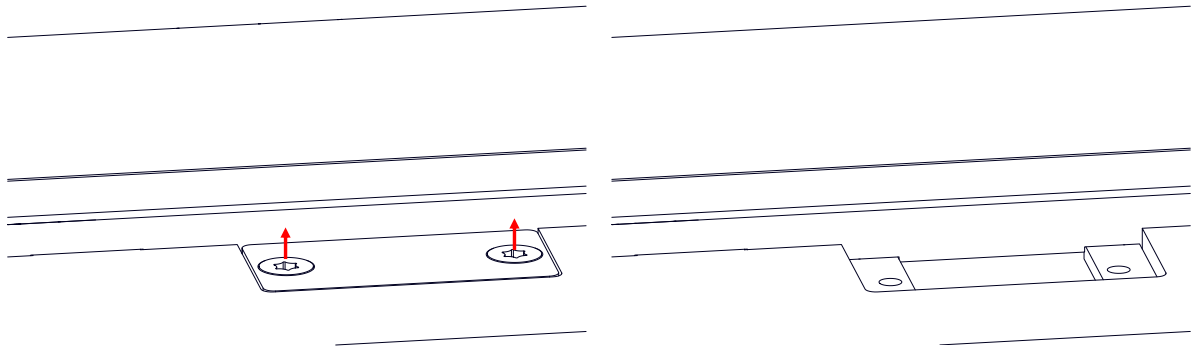

3

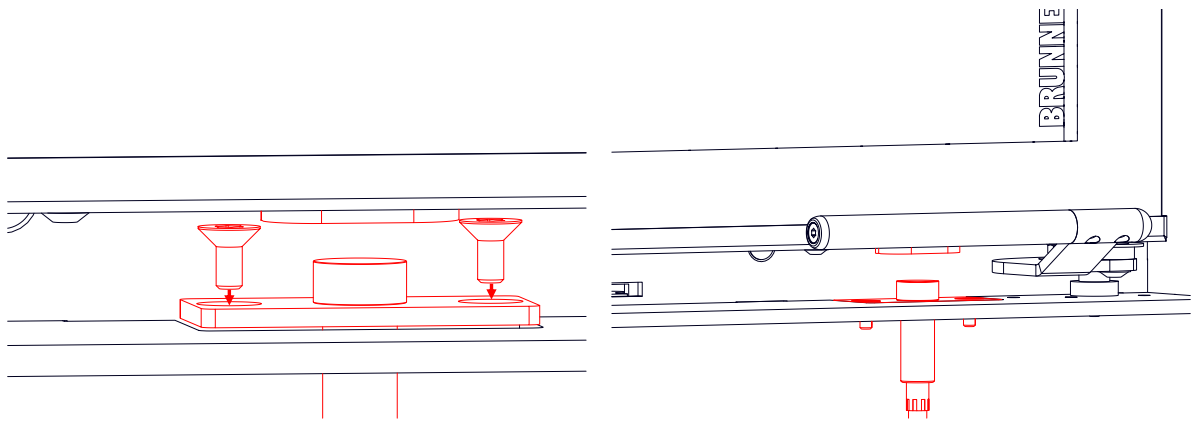

5 FRAME VARIANTS

NOTICE

Rahmen und Seitenteile müssen revisionierbar bleiben!

- Darauf achten, dass Rahmen und Seitenteile wie Blenden nach vollständigem Auf- und Einbau weiterhin revisionierbar sind! Diese Teile nicht verbauen bzw. einmauern.

5.1 DOOR FRAME (BKH WITH SIDE-OPENING DOOR)

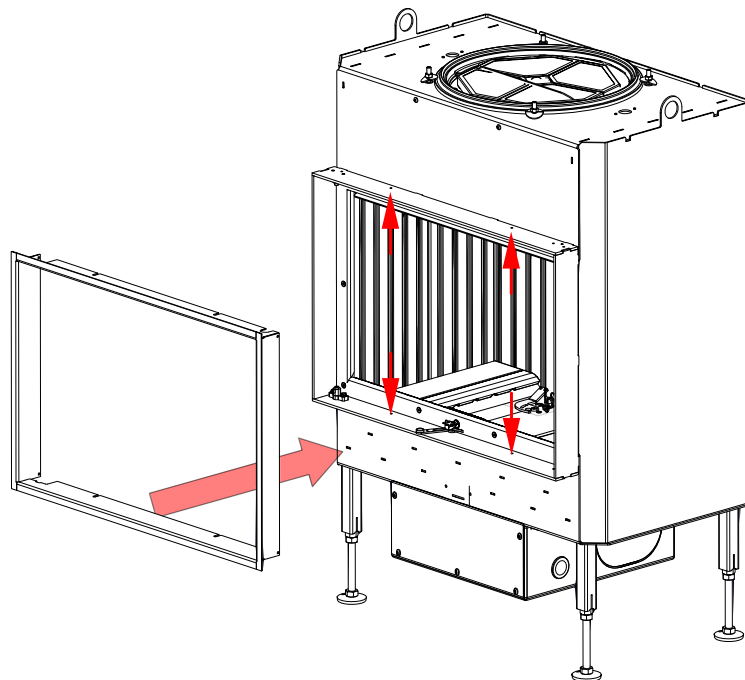

Im. 8: Summarised information

Workflow:

①

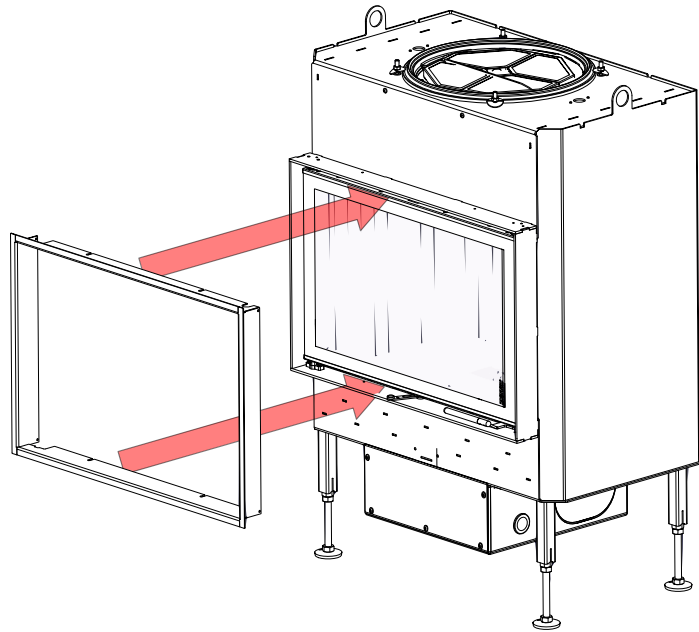

②

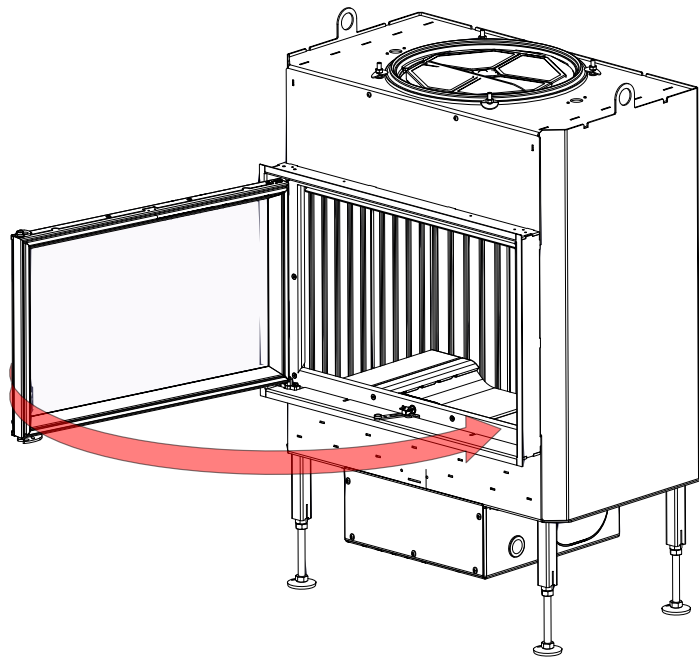

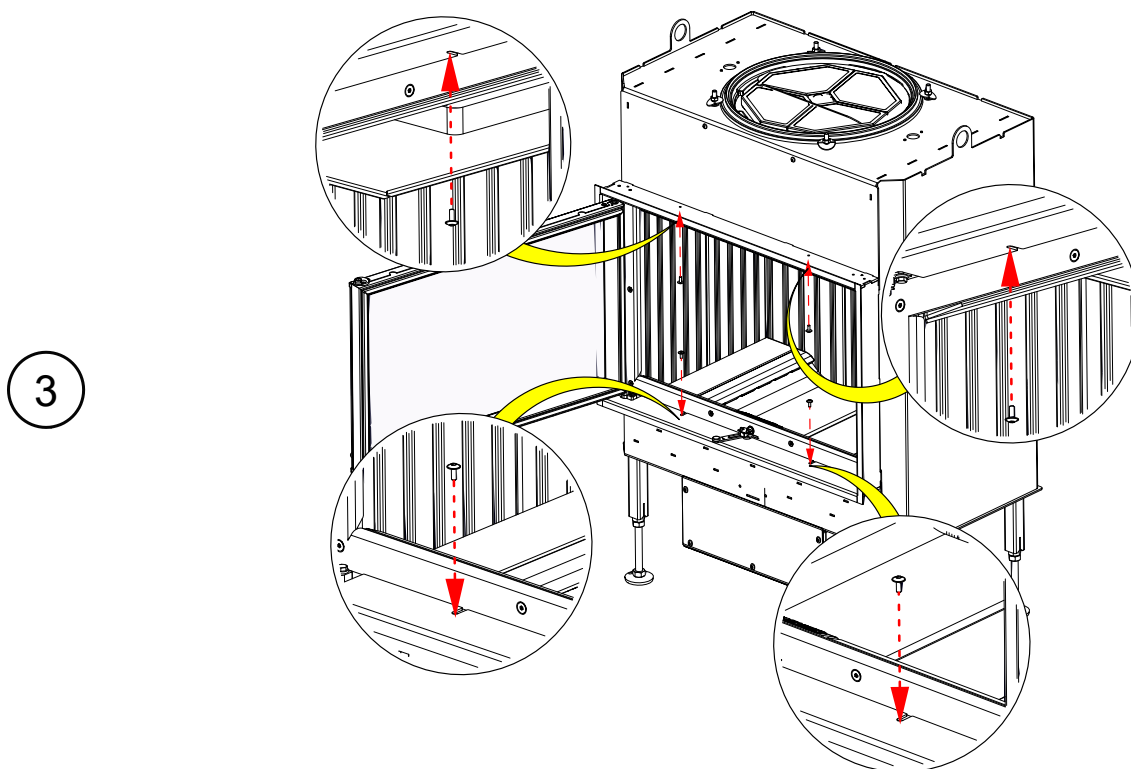

3

6 CONVERSIONS, SETTINGS

6.1 CHANGE OF THE DOOR STOP

Summarised information:

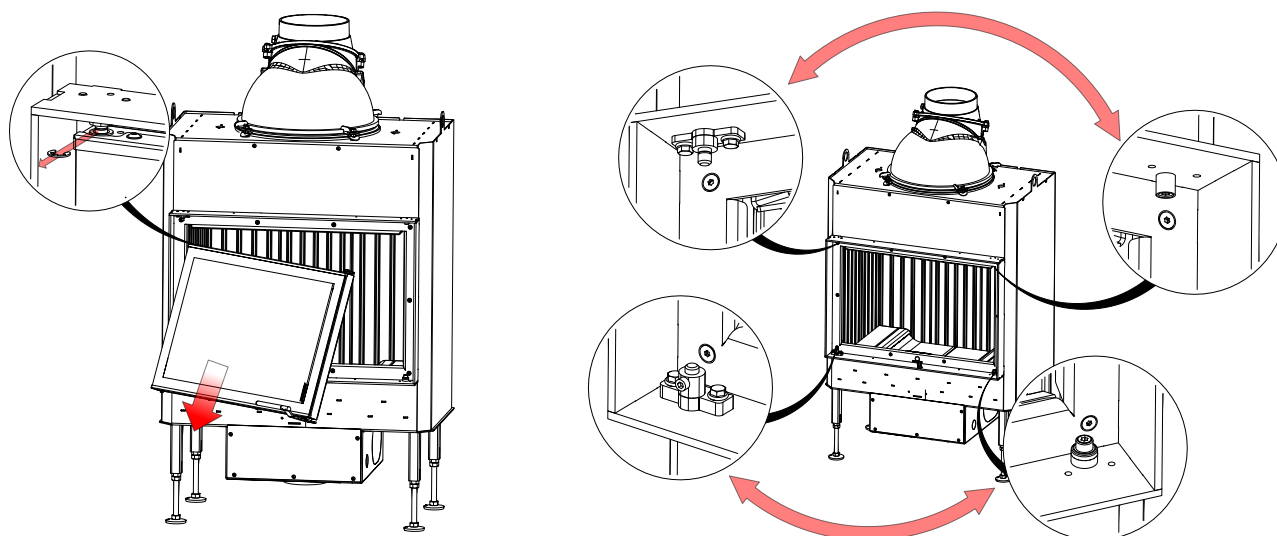

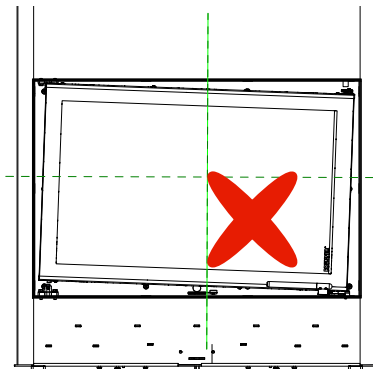
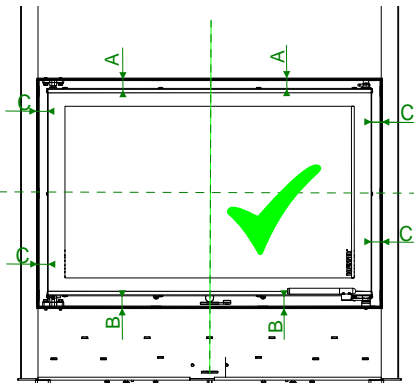
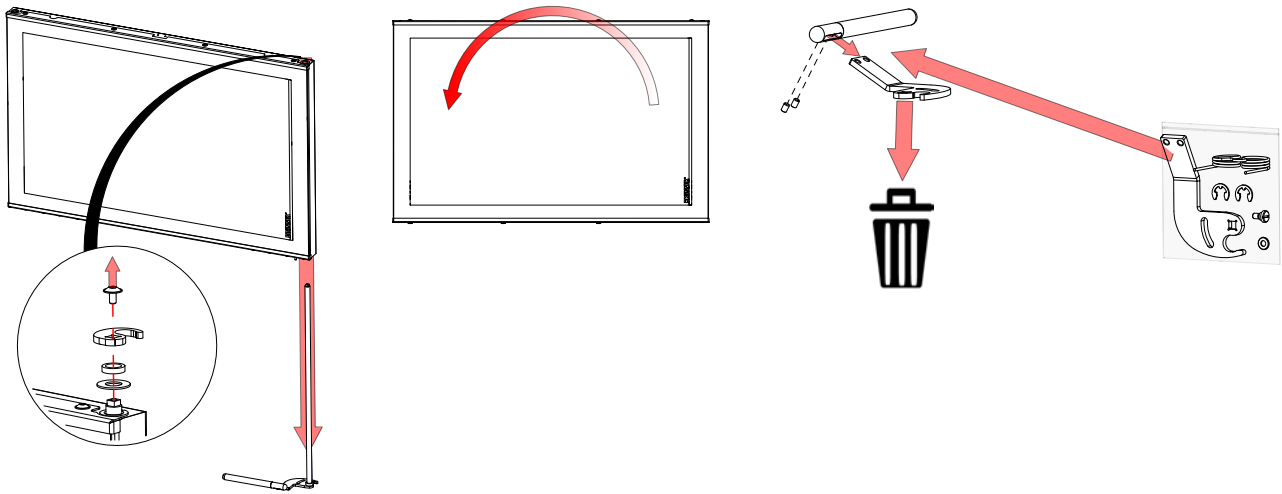

Adjust door !!

The door must be aligned vertically and horizontally. When the door is closed, the sealing cord of the door must be tight to the body.

Additional info: <https://www.brunner.de/de/>

Workflow:

1

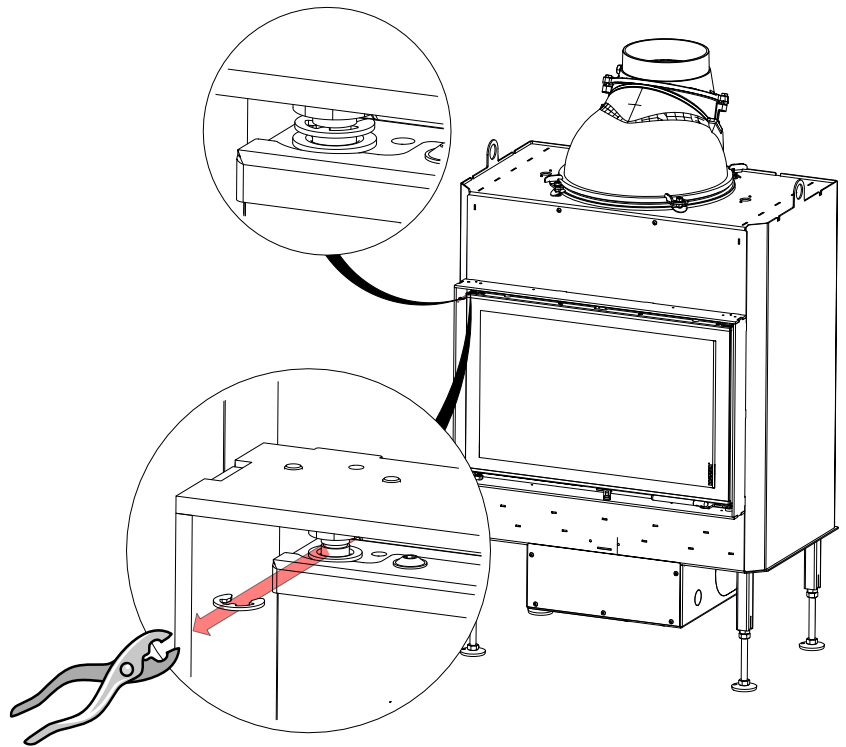

2

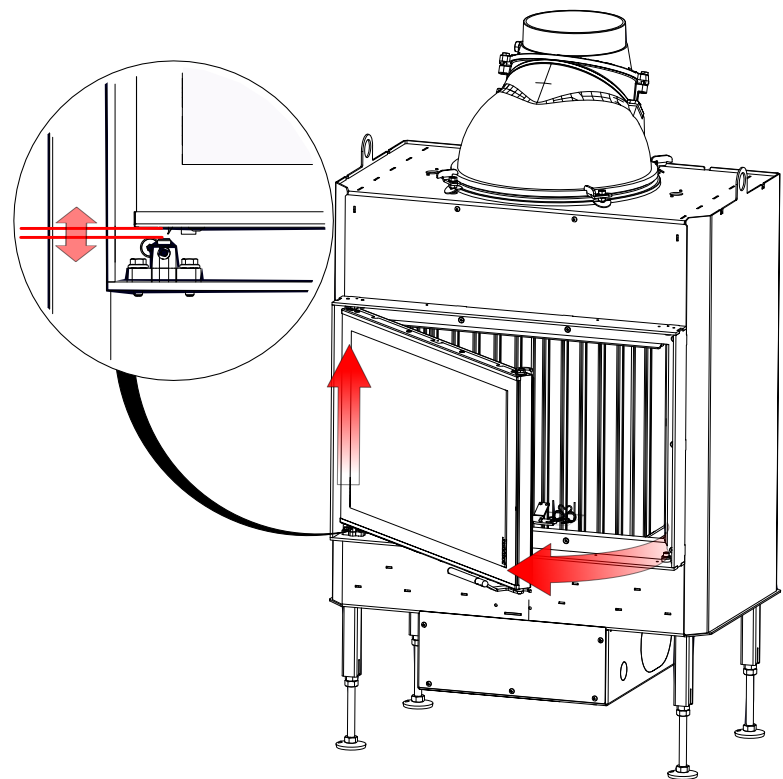

3

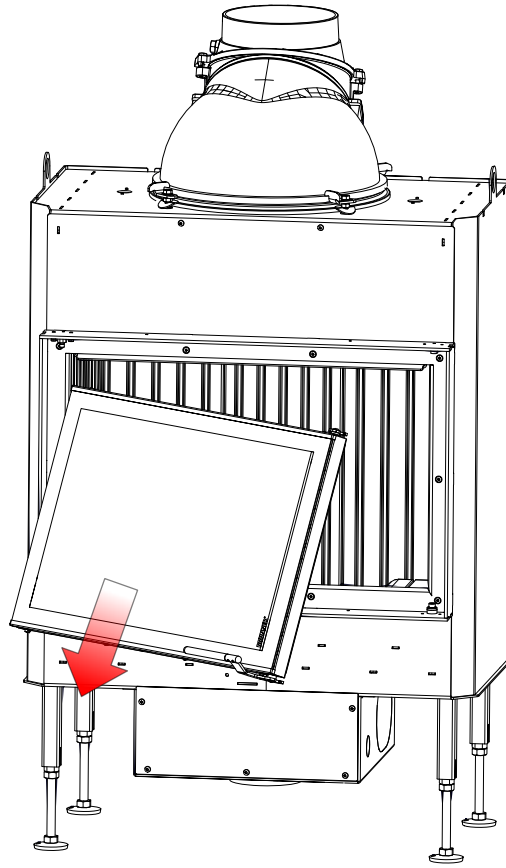

i

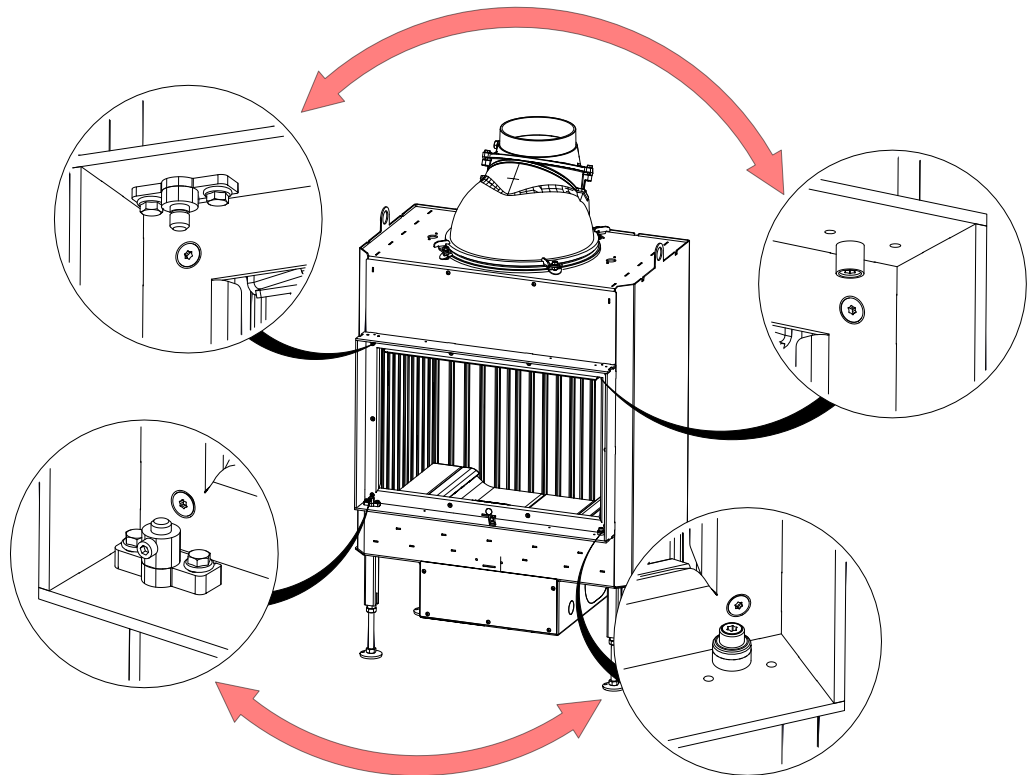

4

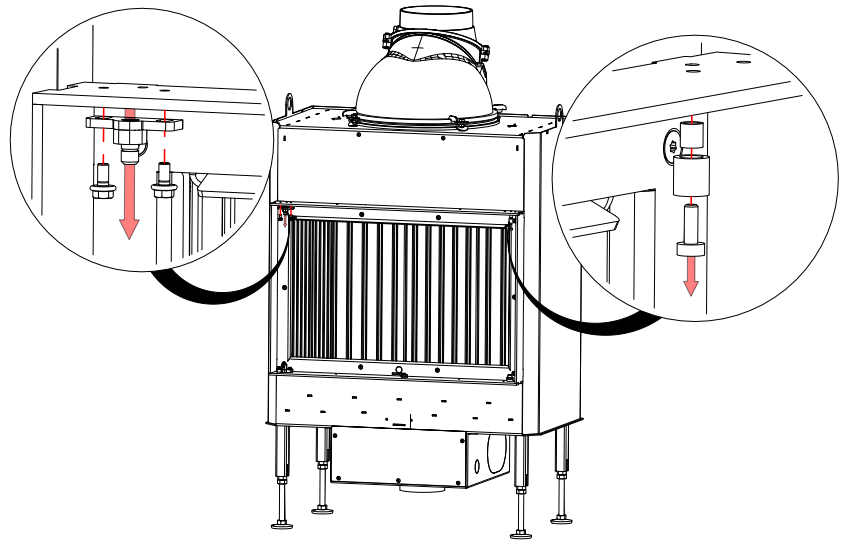

5

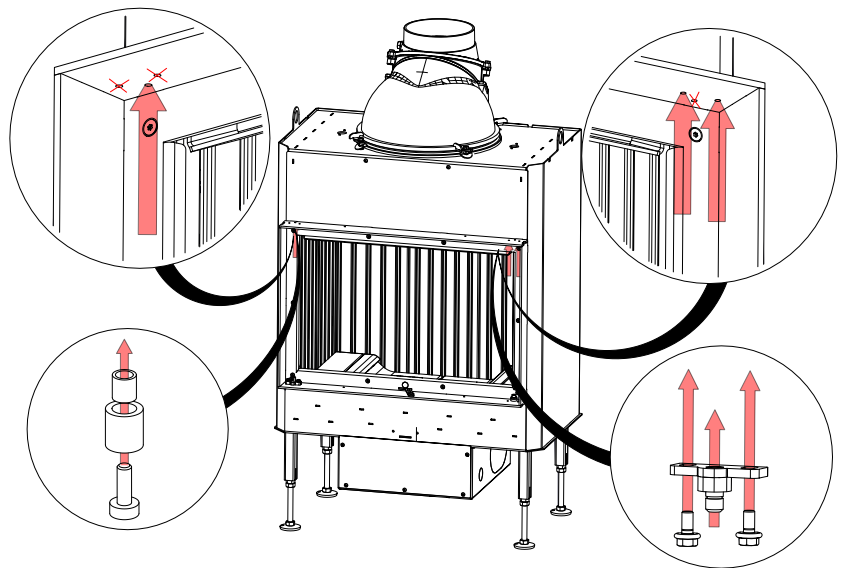

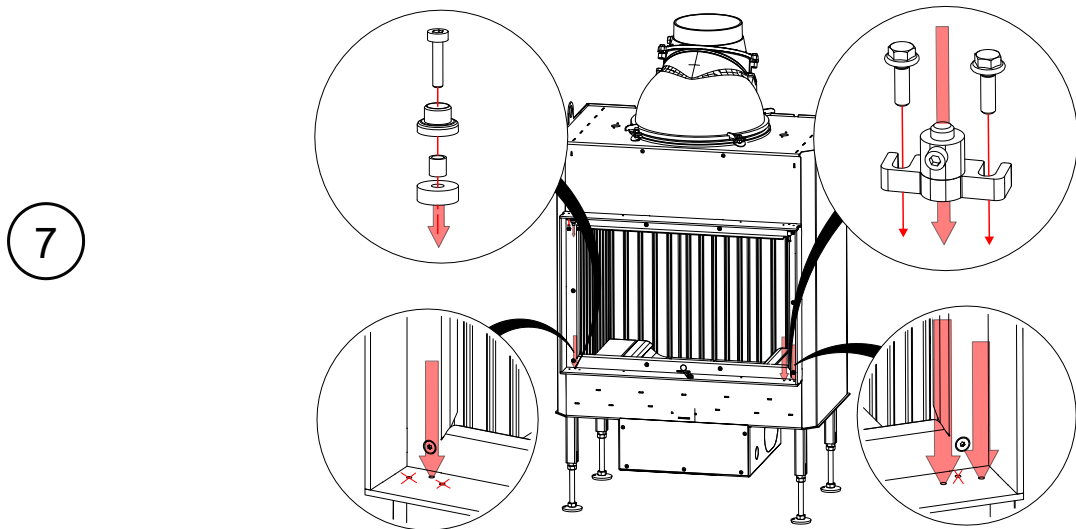
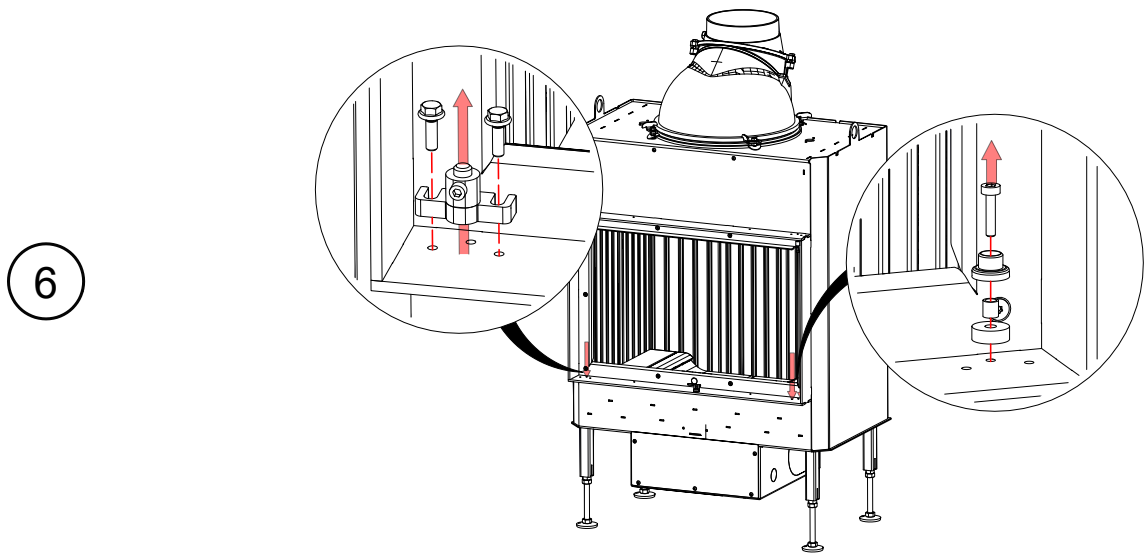

8

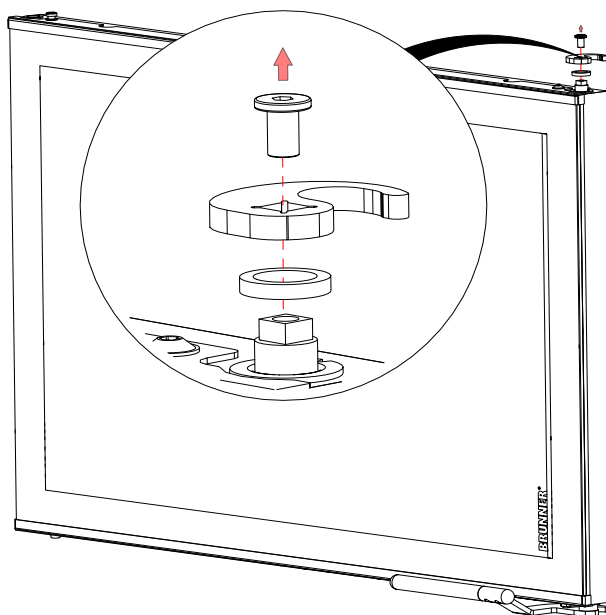

9

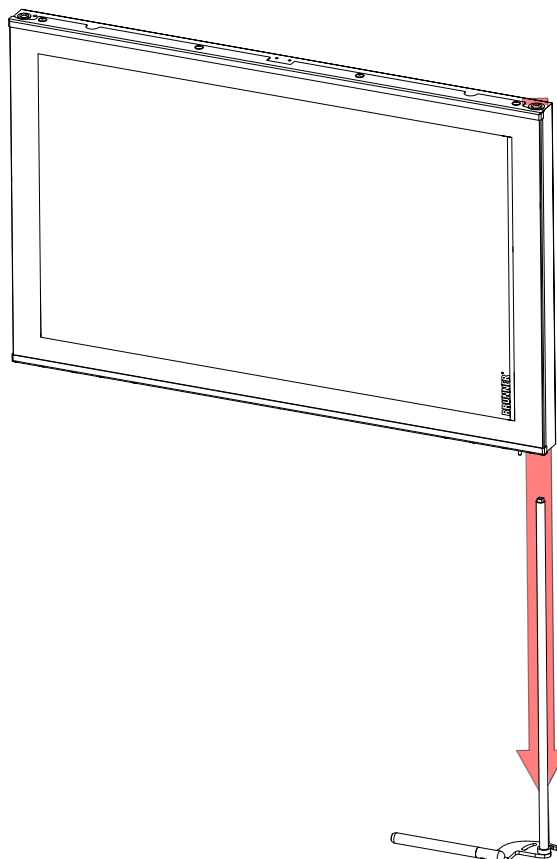

10

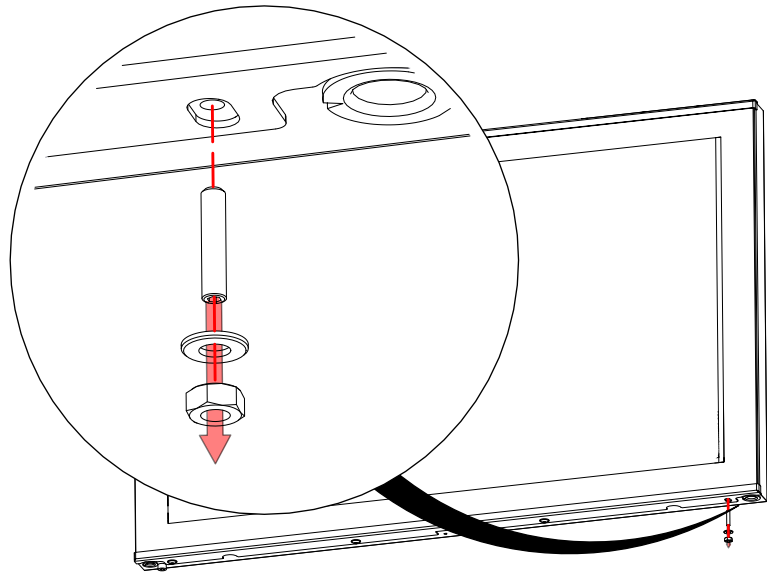

11

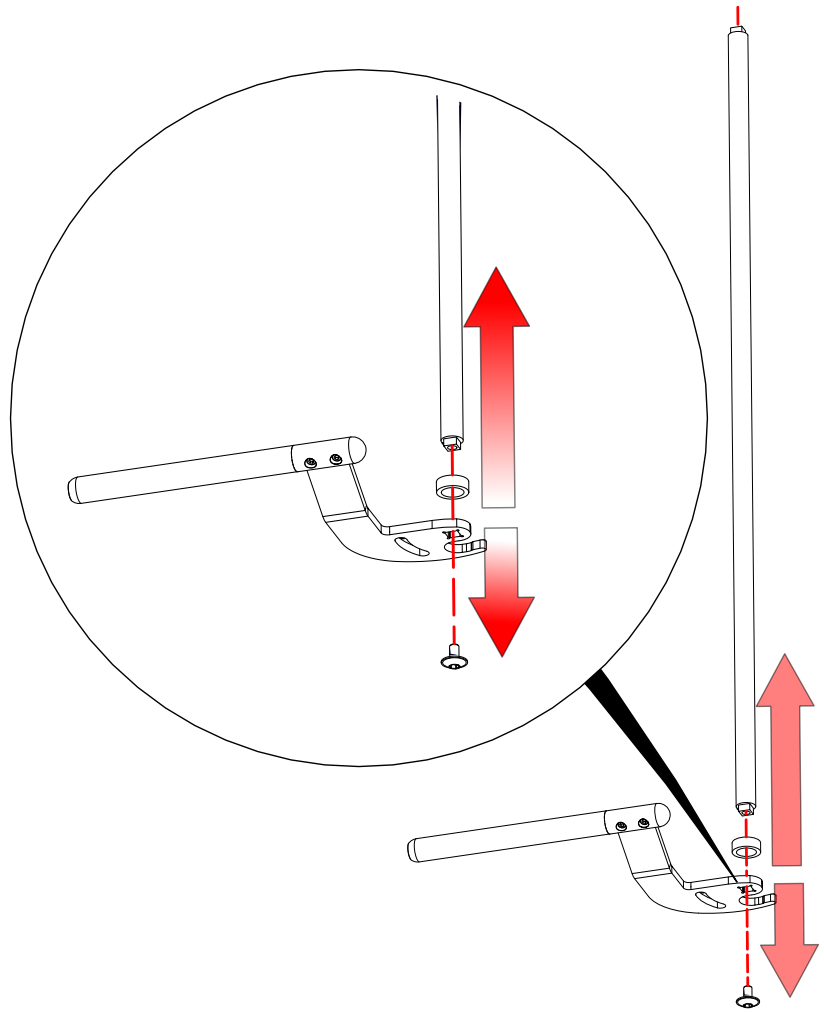

12

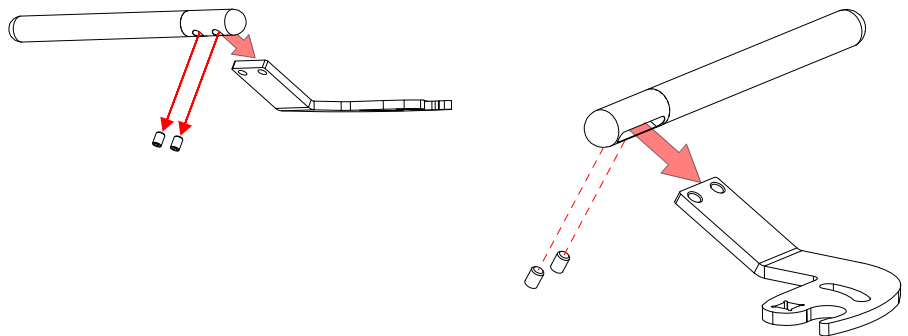

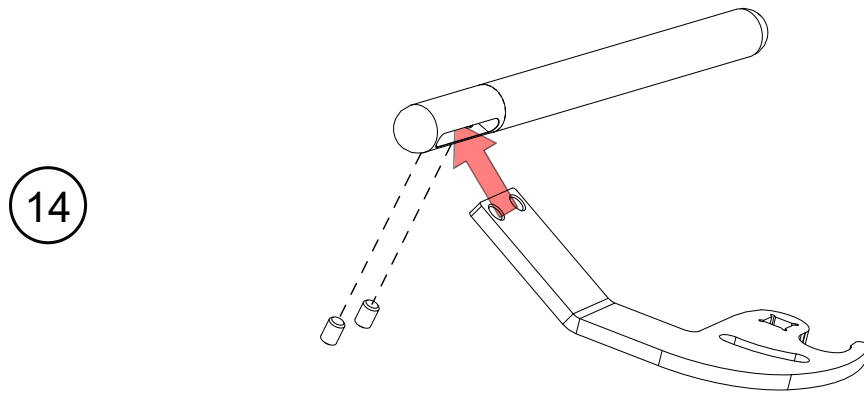
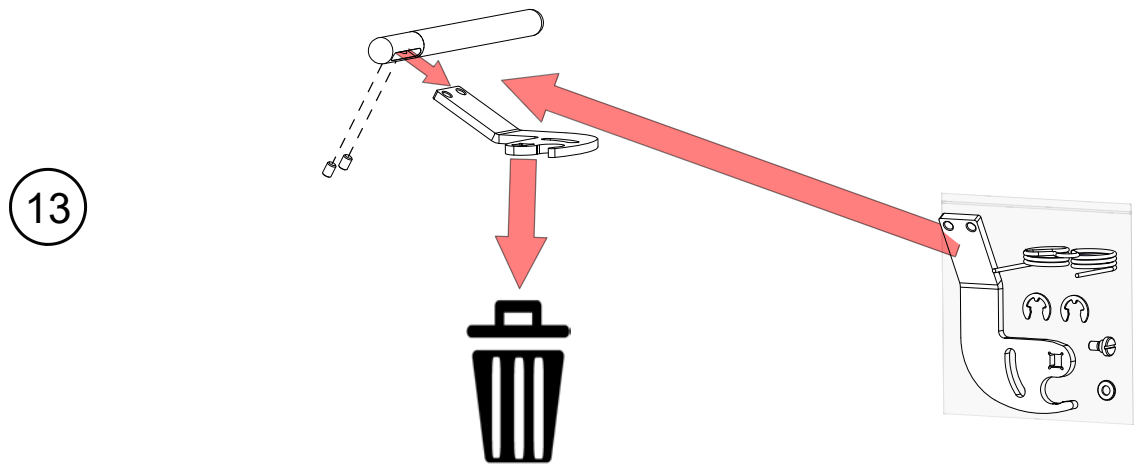

15

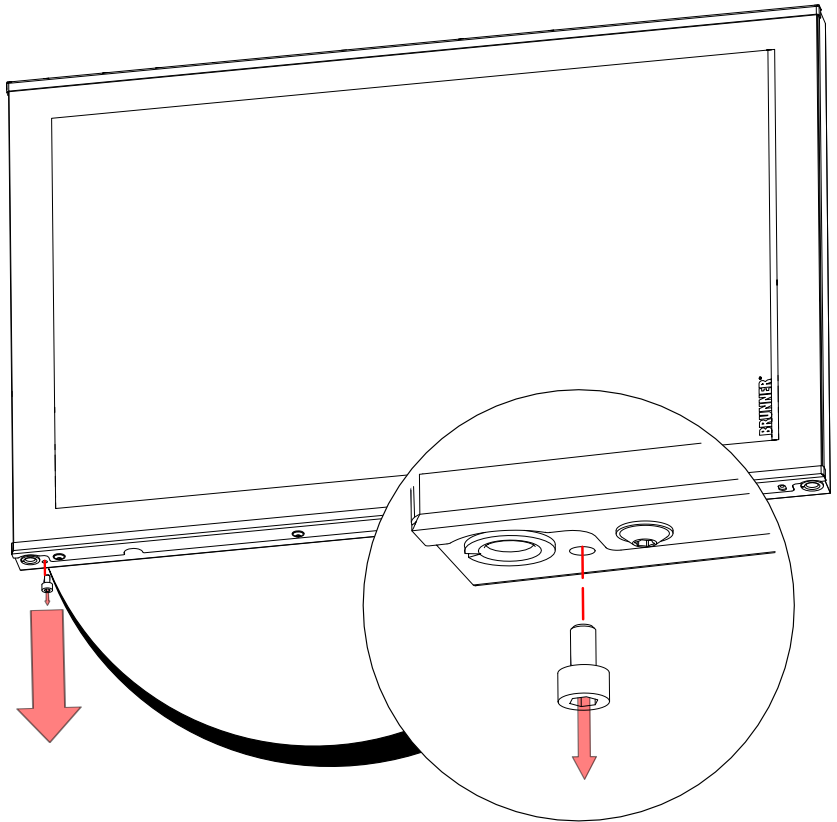

16

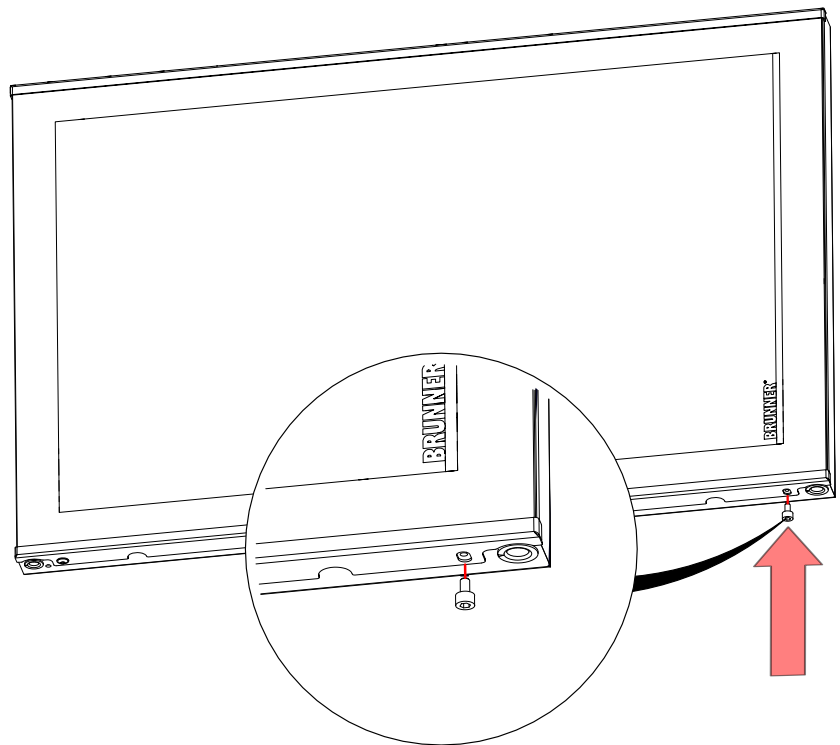

17

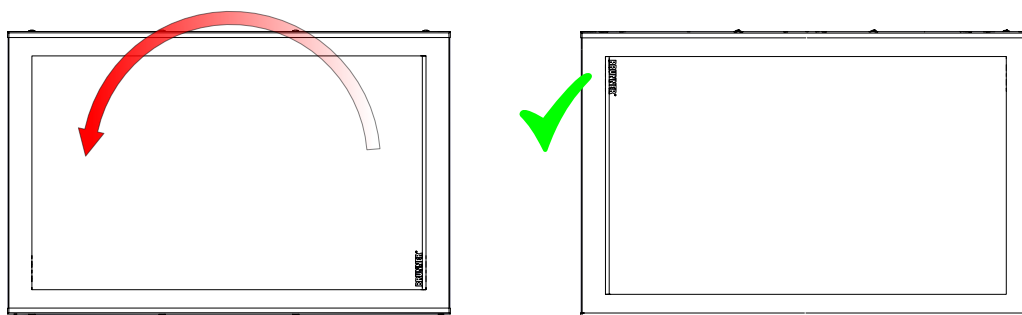

18

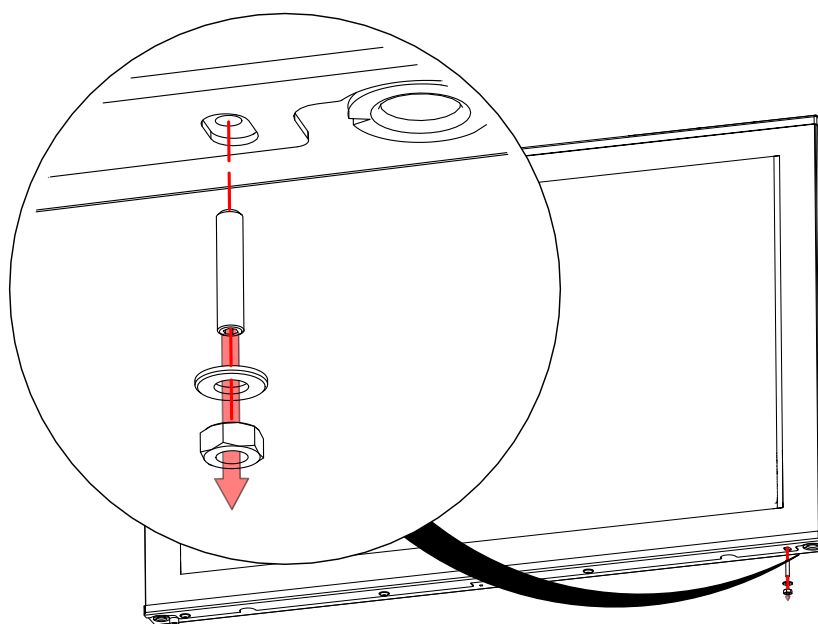

19

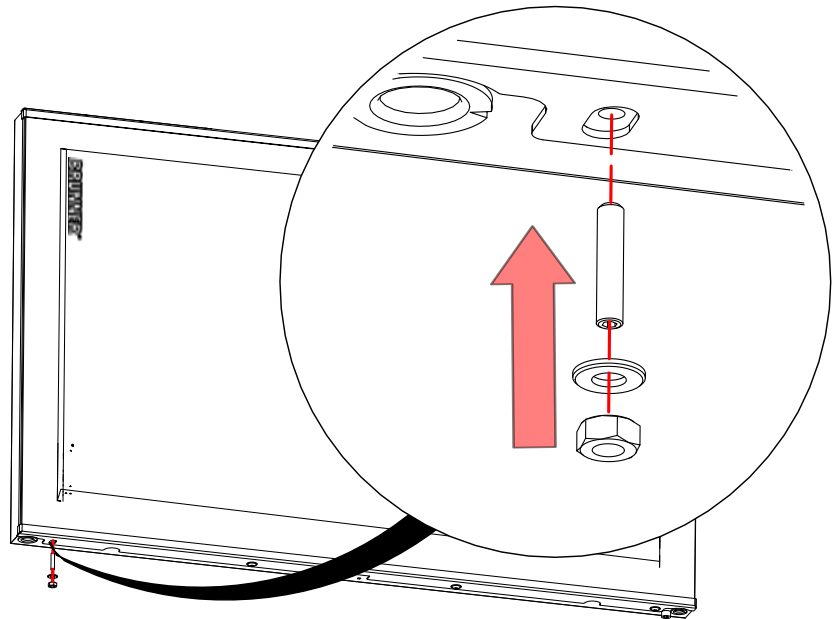

20

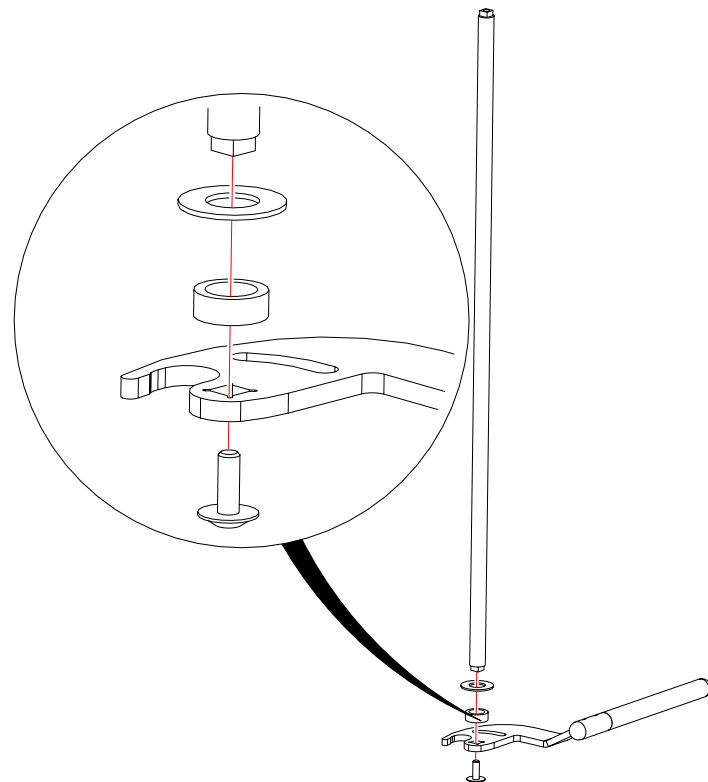

21

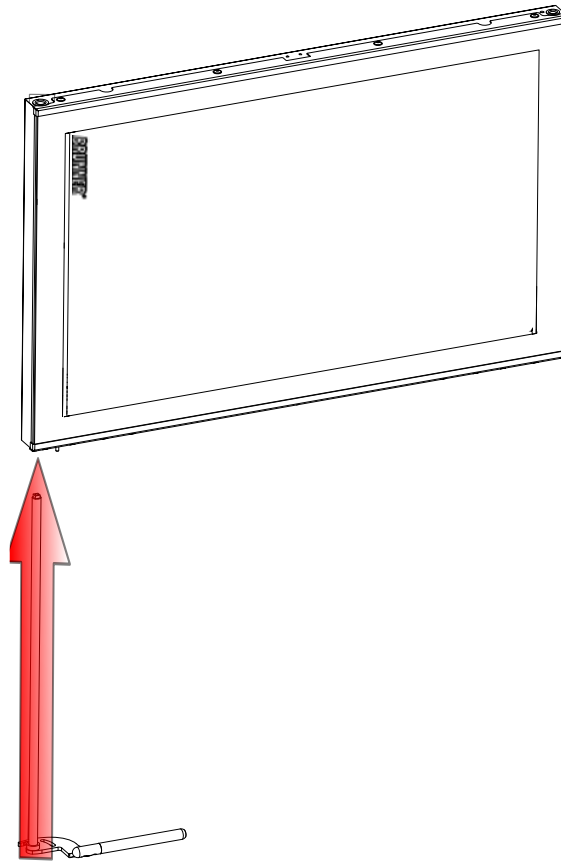

22

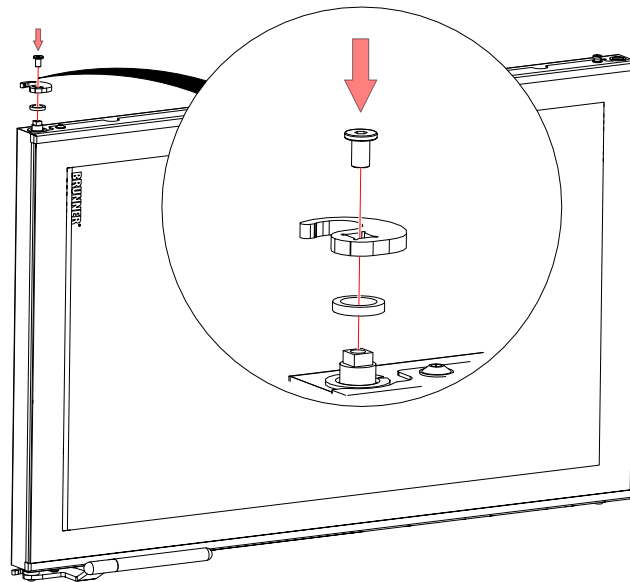

23

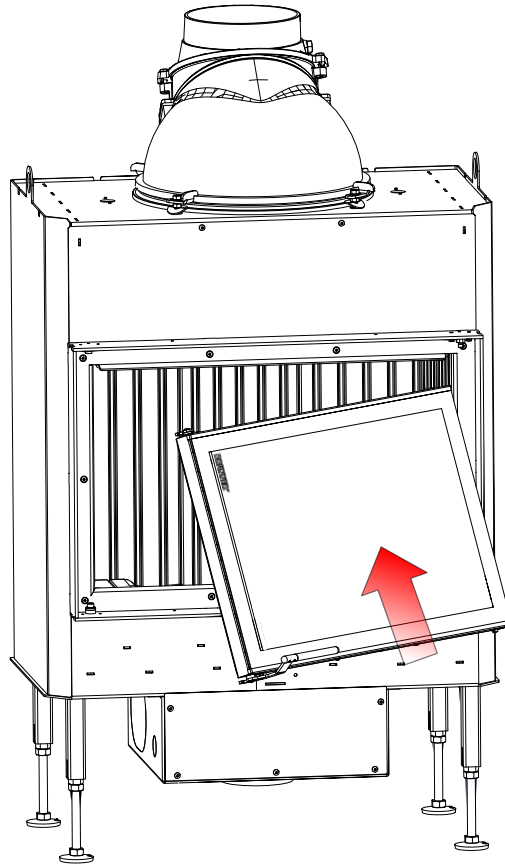

24

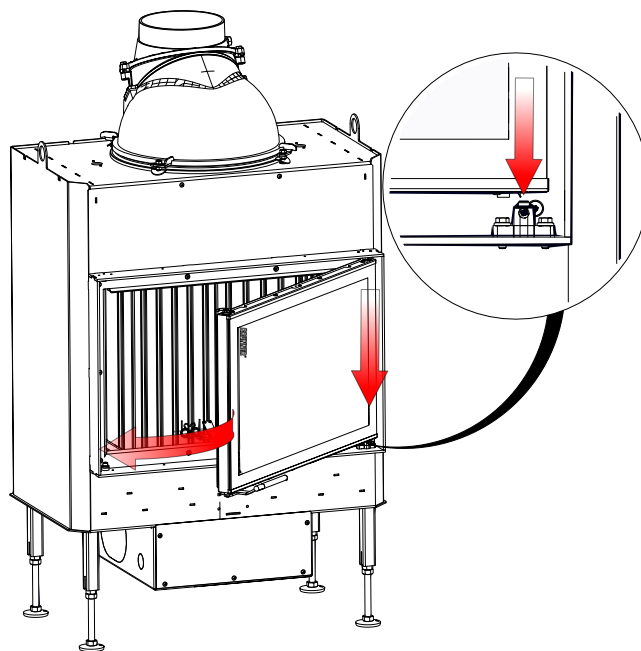

25

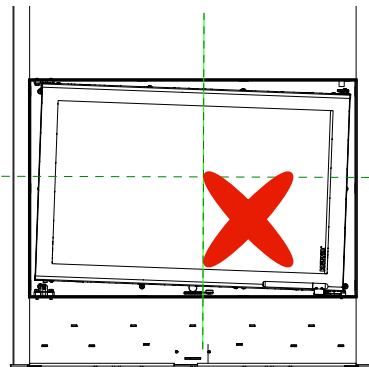
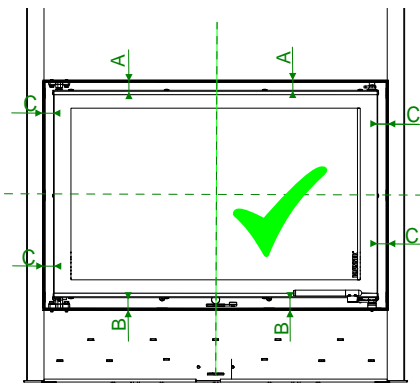
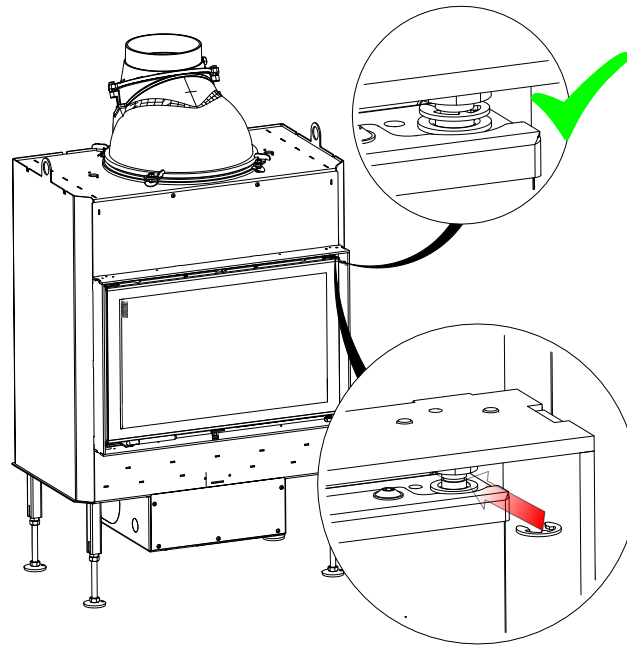

Adjust door !!

The door must be aligned vertically and horizontally. When the door is closed, the sealing cord of the door must be tight to the body.

6.2 ADJUSTING OF SELF-CLOSING DOOR

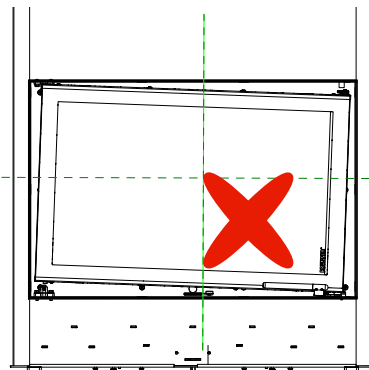
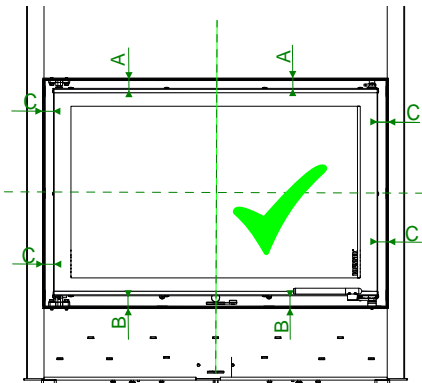
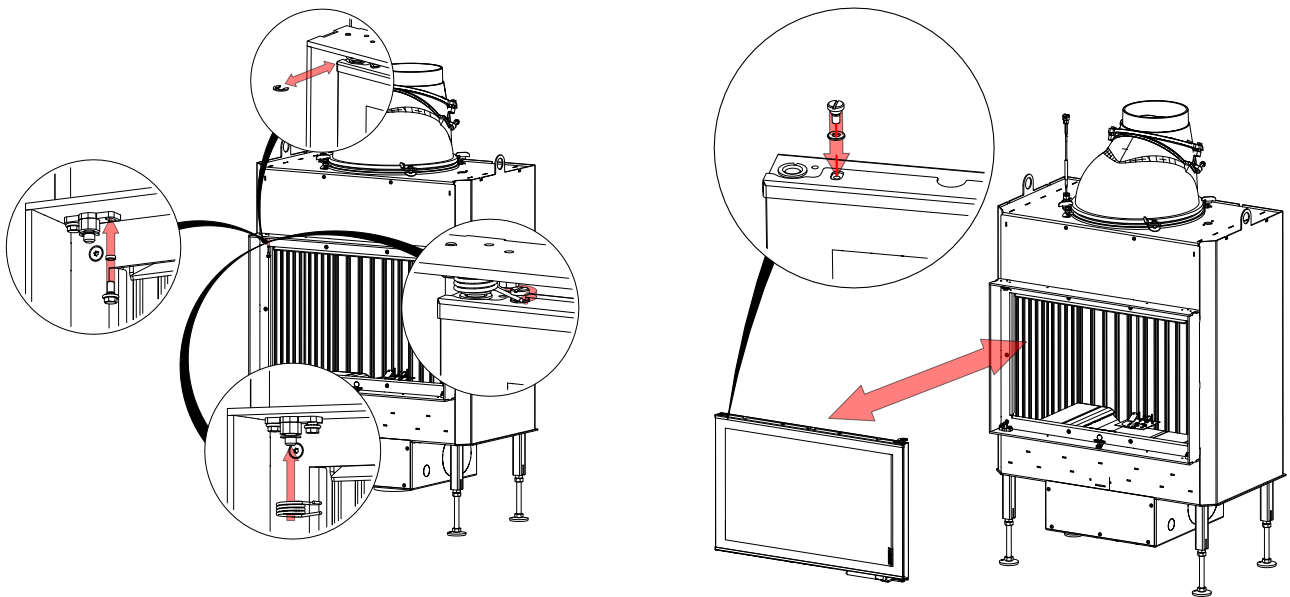

Adjust door !!

The door must be aligned vertically and horizontally. When the door is closed, the sealing cord of the door must be tight to the body.

Version : BKH with side-opening door

-> without self-closing

1

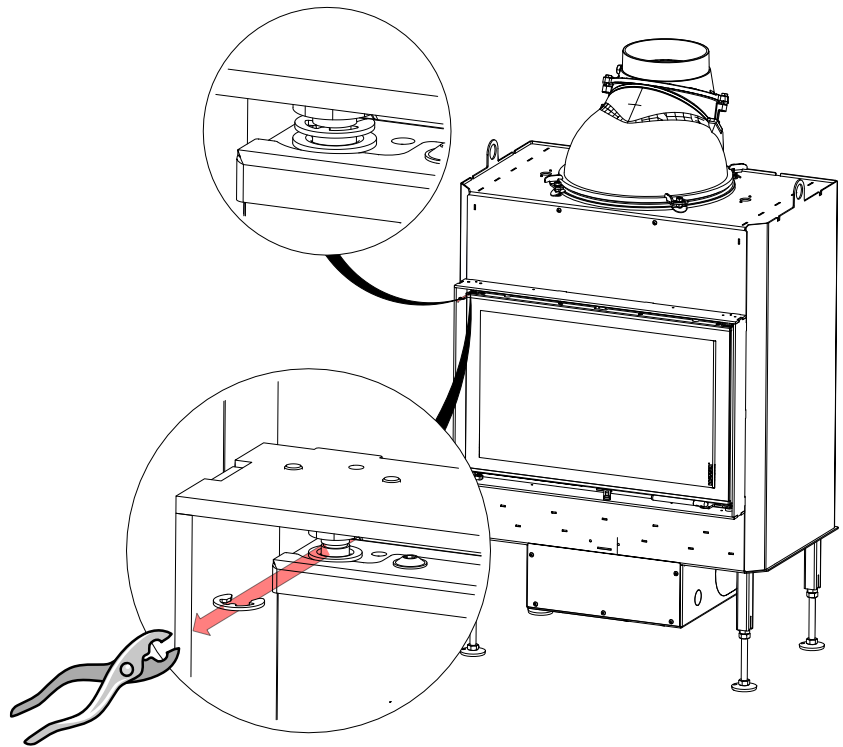

2

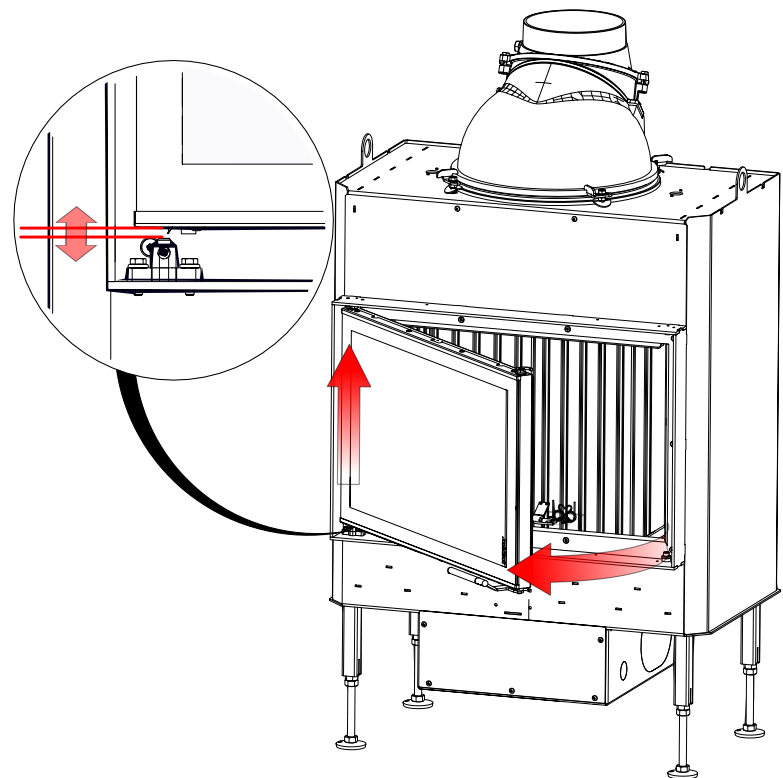

3

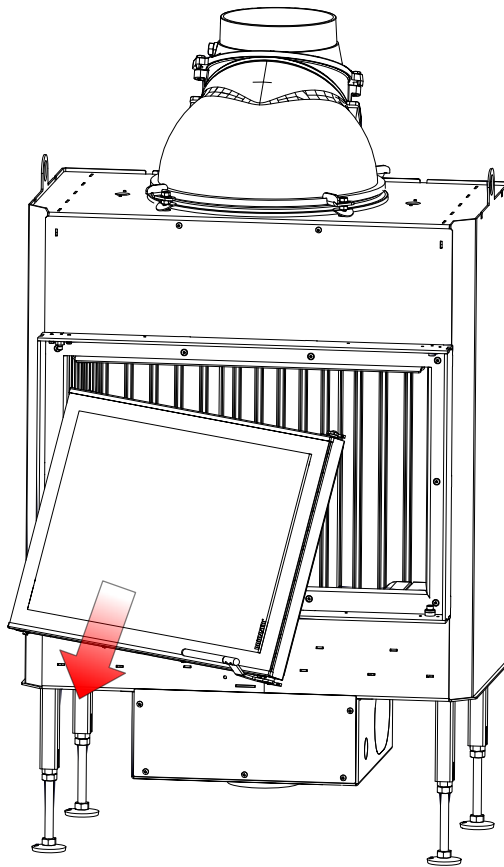

4

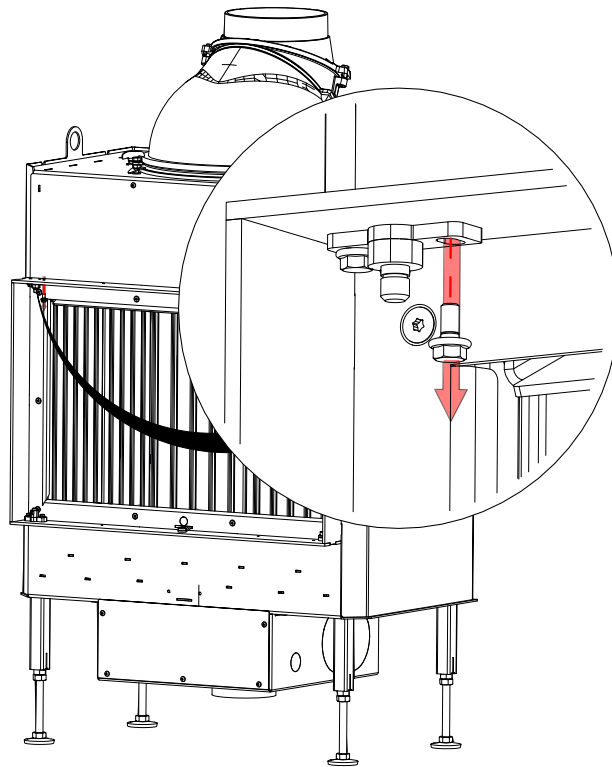

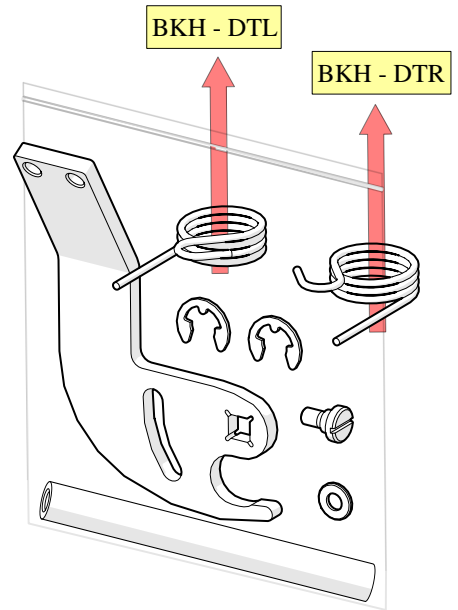
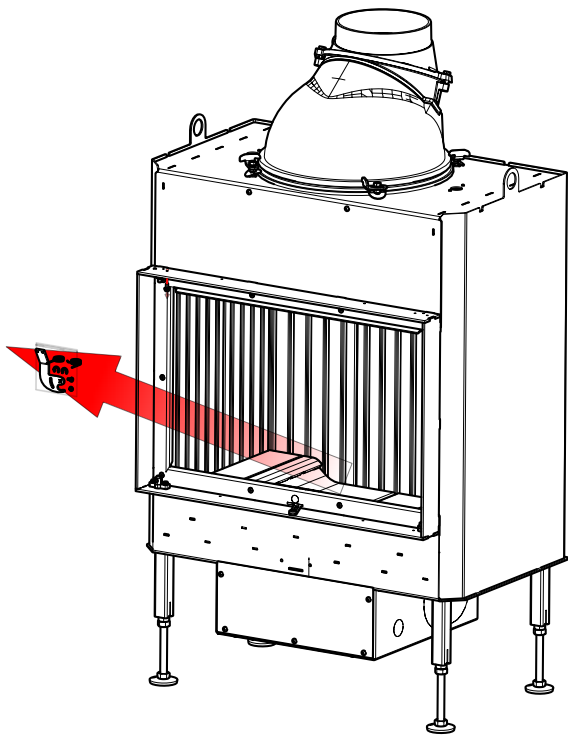

DTL = side-opening door - left side
DTR = side-opening door - right side

5

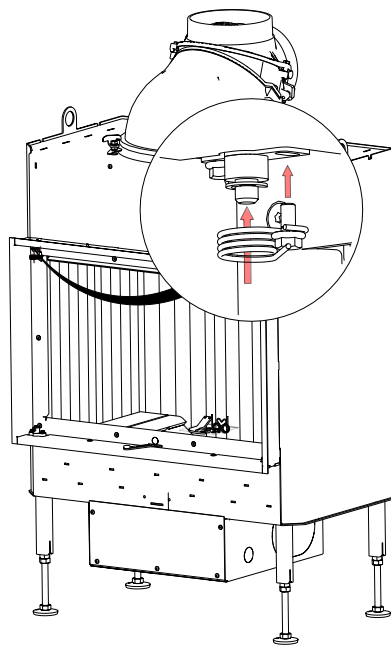

Mounting aid:

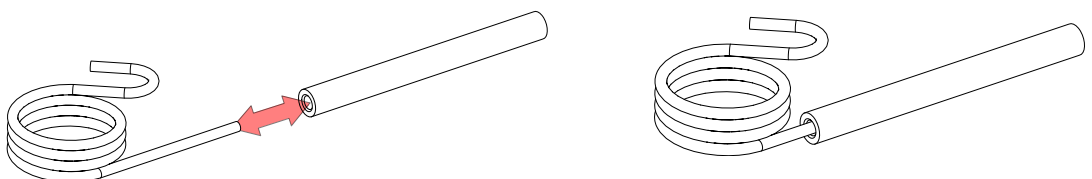

6

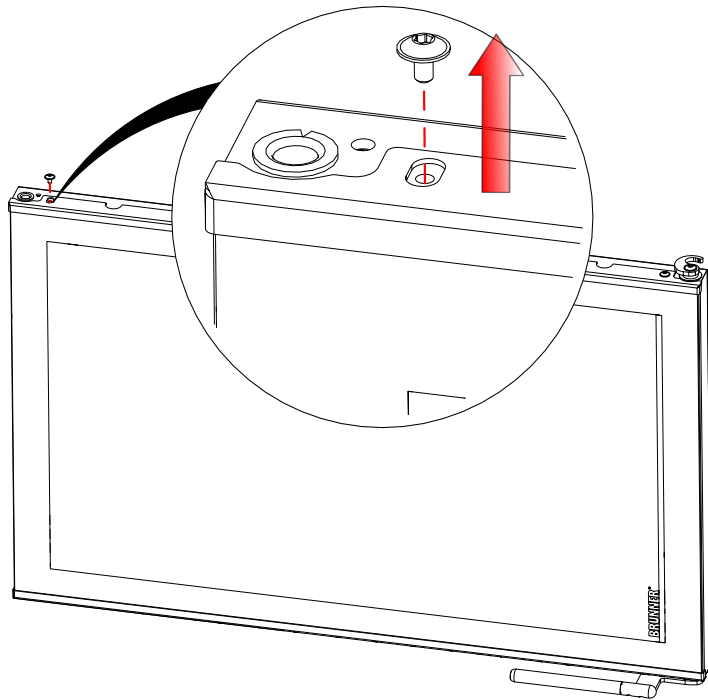

7

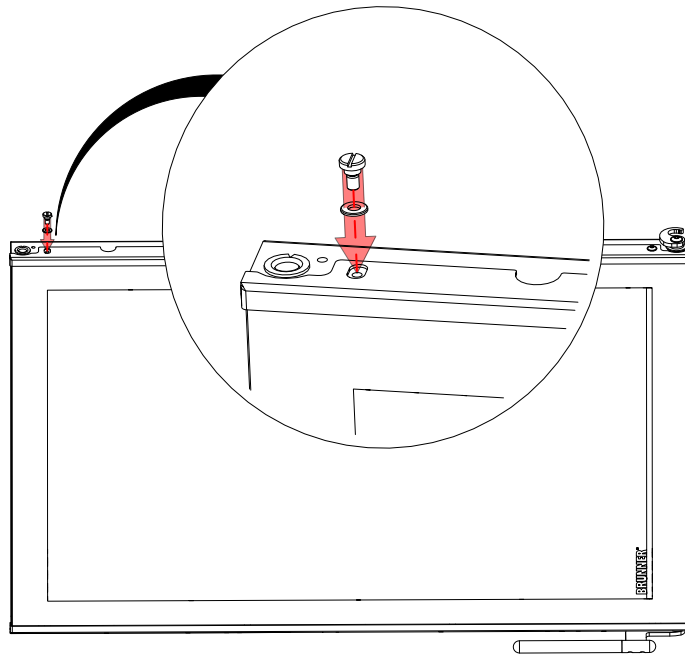

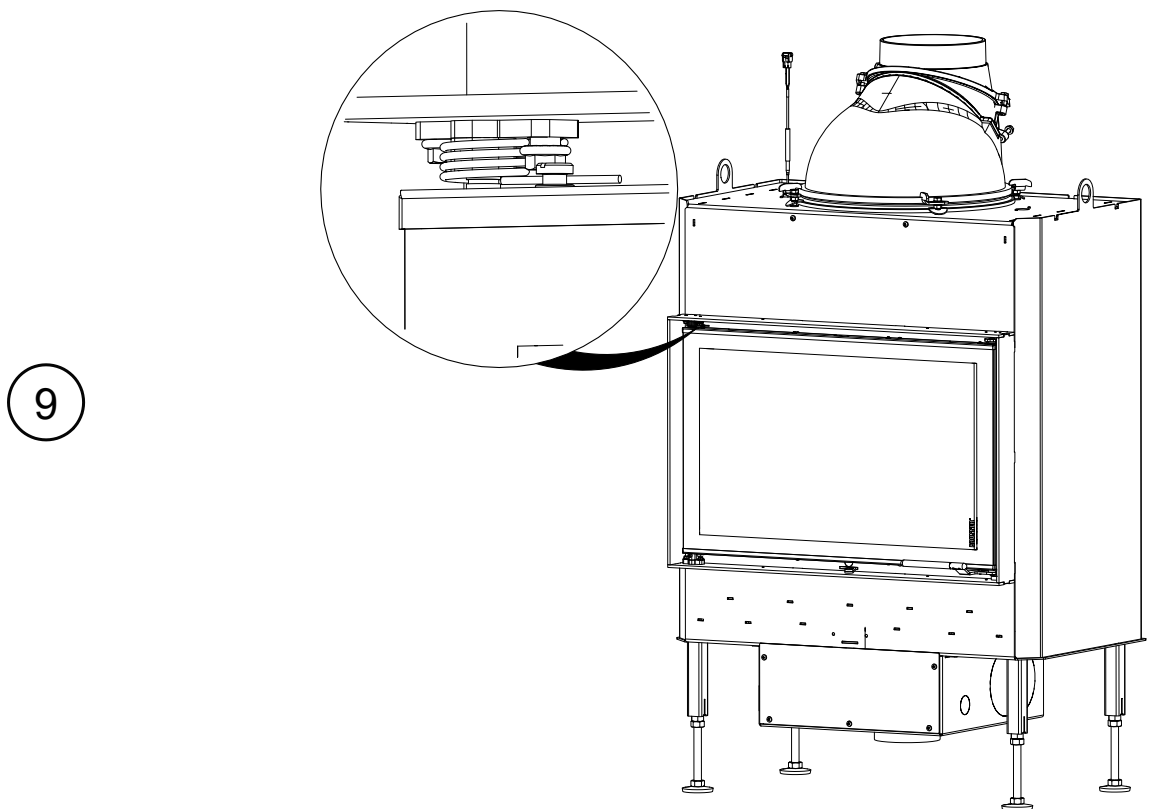
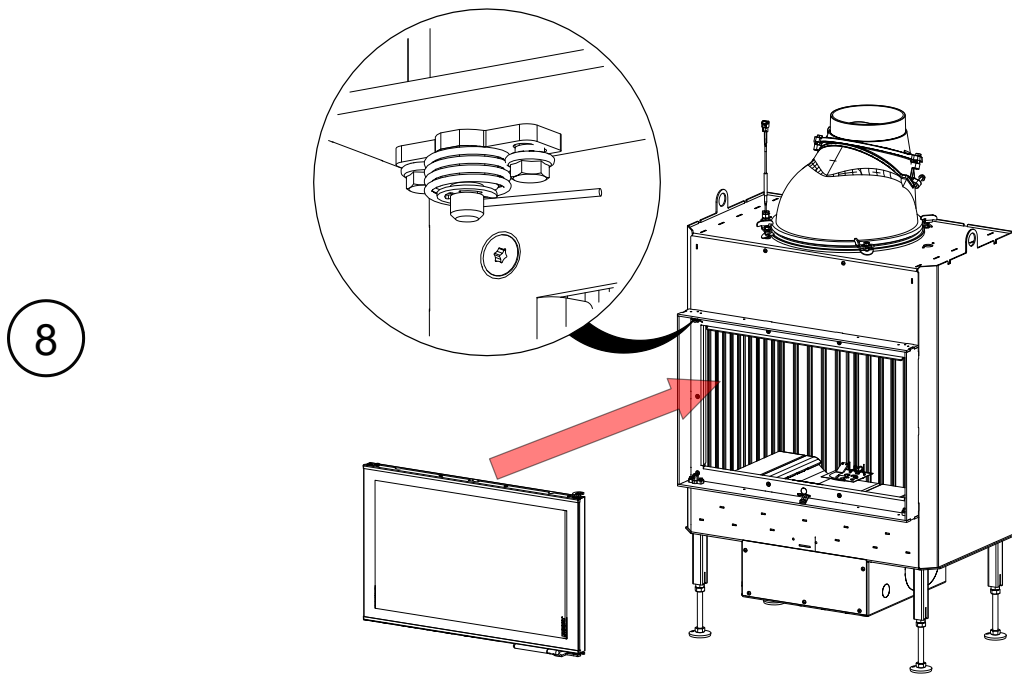

Mounting aid:

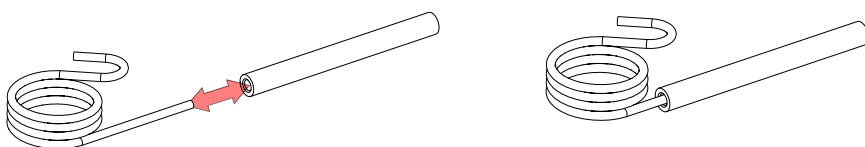

10

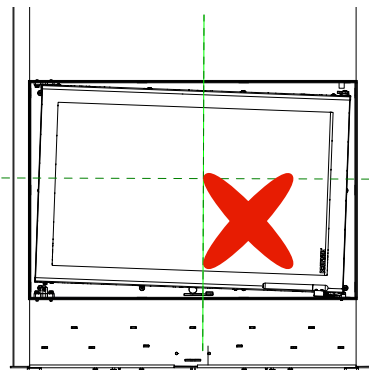
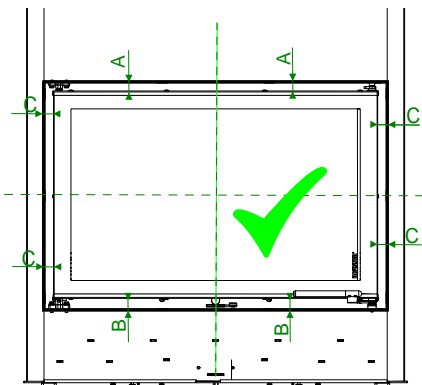
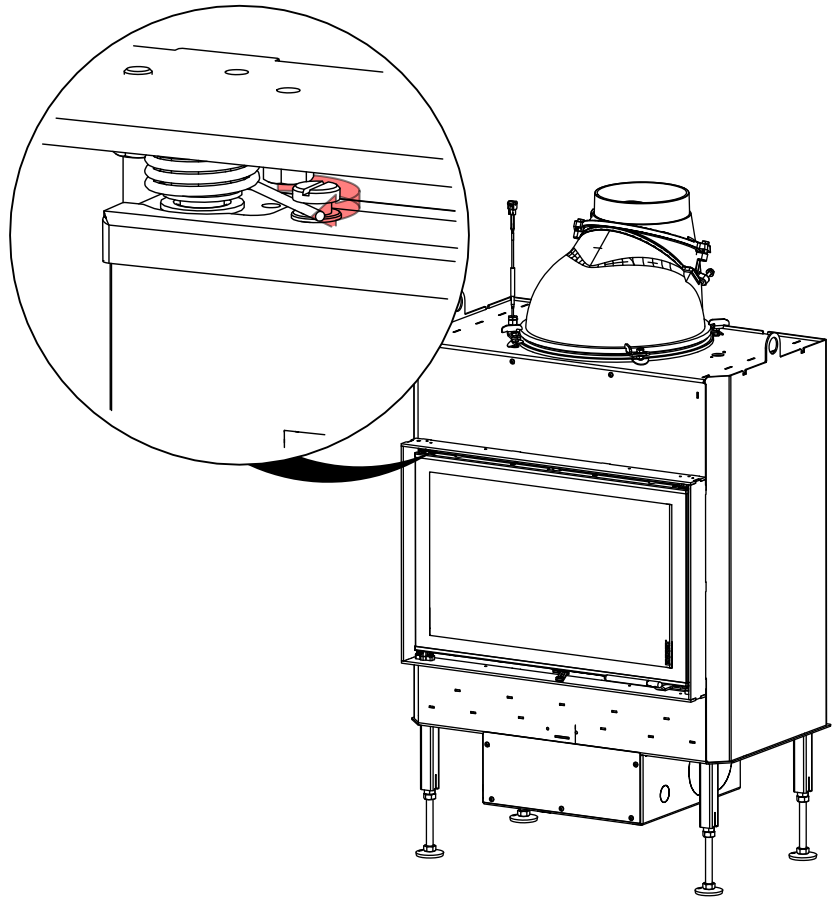

Adjust door !!

The door must be aligned vertically and horizontally. When the door is closed, the sealing cord of the door must be tight to the body.

Version : BKH with lifting door

-> Self-closing is active in the delivery state..

6.3 MODIFICATION - LIFTING DOOR: "NON SELF CLOSING"

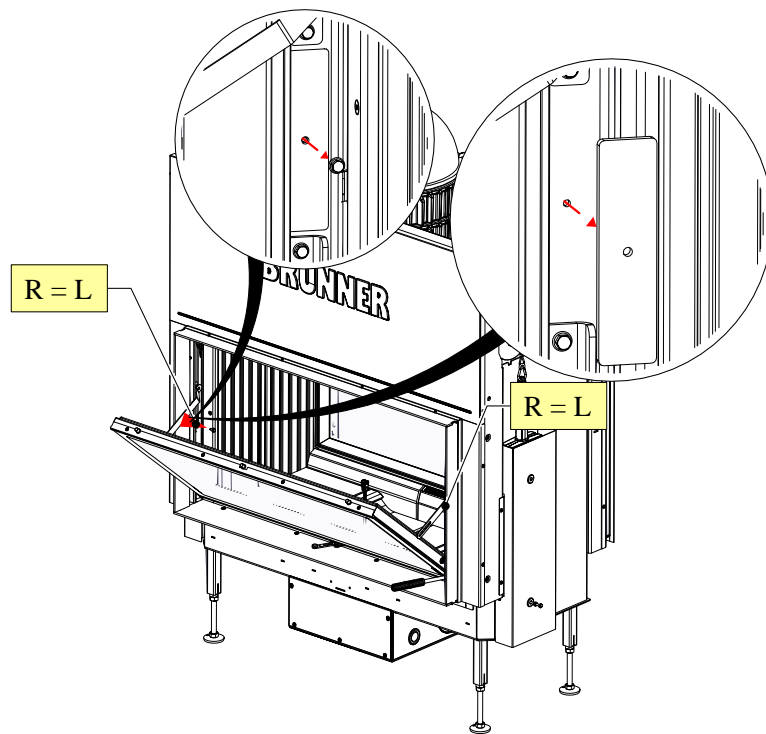

R = right side

L = left side

Im. 9: Summarised information

Workflow:

1

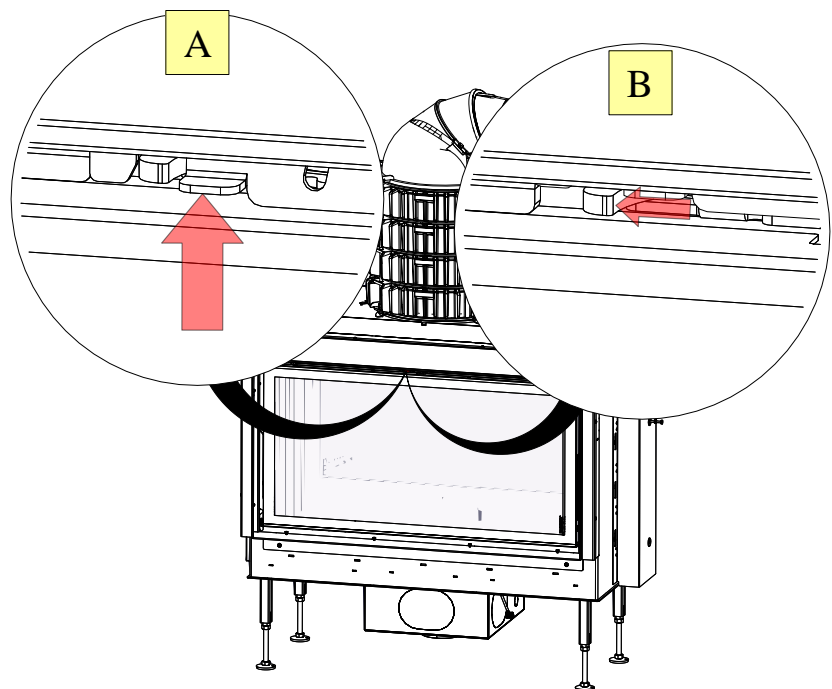

2

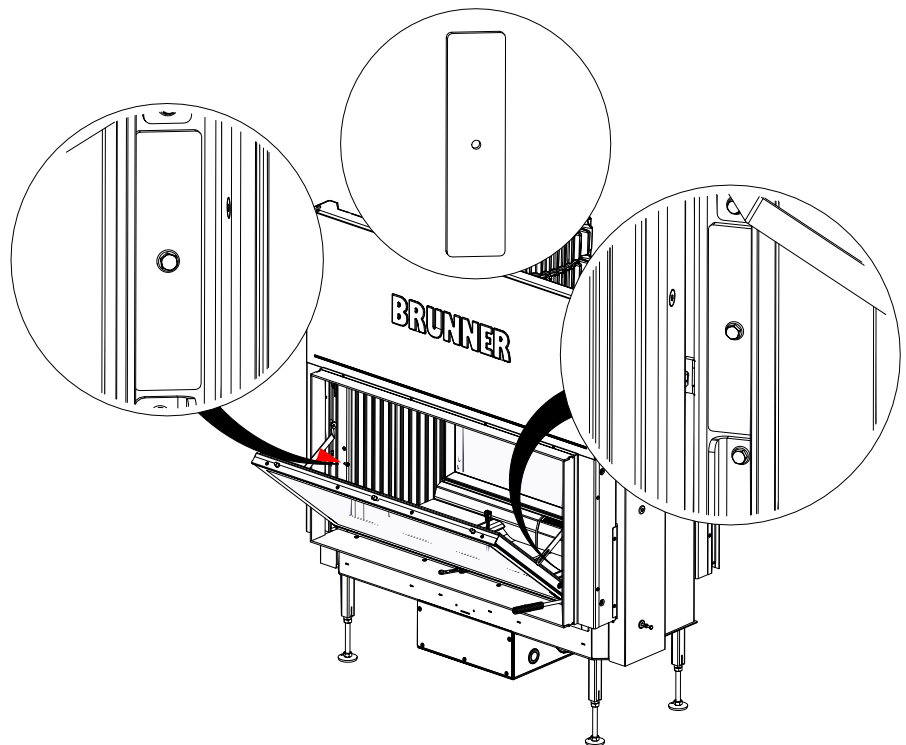
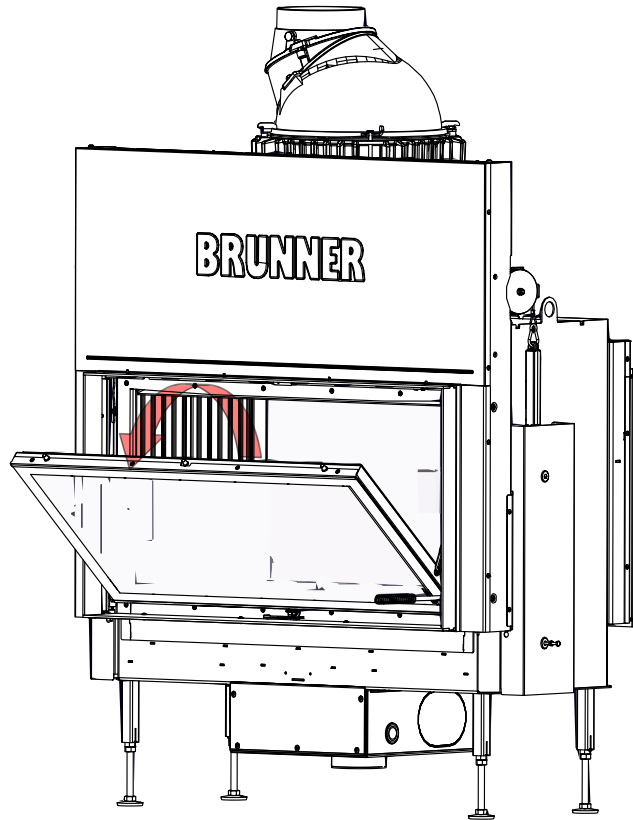

3

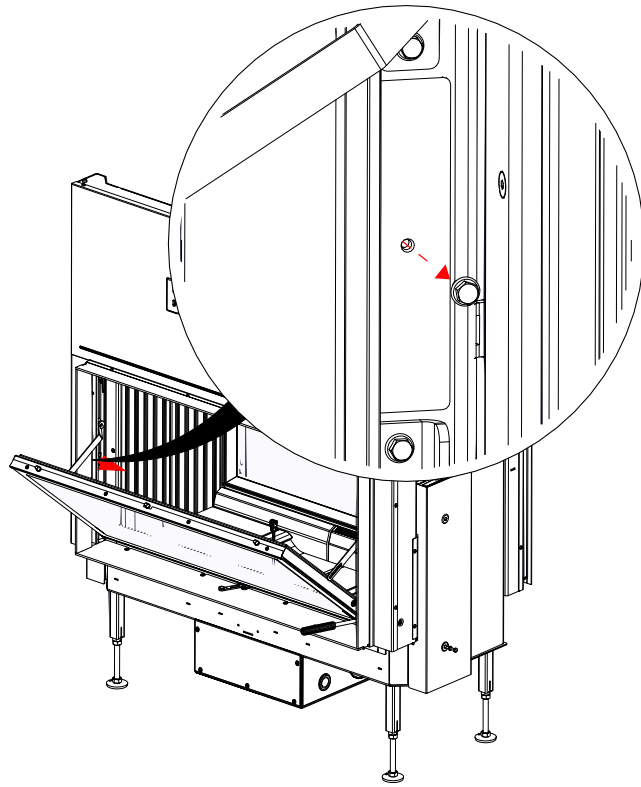

4

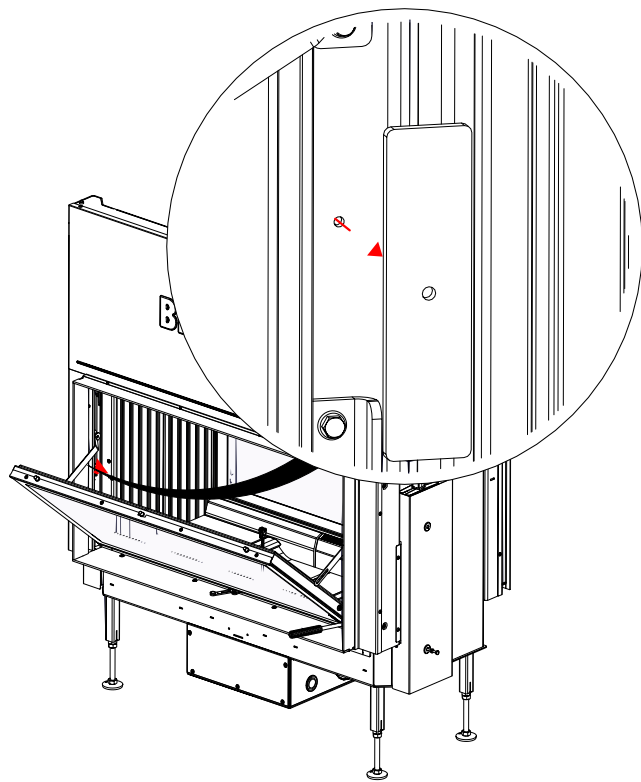

7 DISPOSAL

Old equipment contains valuable materials that must be recycled. Observe the applicable national legal regulations for disposal.



Danger of electrocution.

Electrical connections of the furnace system are under mains voltage. This can lead to electric shock.

Switch off the power supply

Secure power supply against restart.

Old metal parts can be disposed of as metal recycling.

Electrical and electronic components must be disposed of as electronic waste. Fireclay linings can be disposed of as rubble.

Fireclay linings can be disposed of as rubble.

Dispose of insulating and insulating materials of the heating or fireplace insert in a closed container on a suitable waste disposal site.

Do not put the glass ceramic discs in the waste glass collection container! The glass panes can be disposed of as normal household waste.

Recycling of catalytic converters containing precious metals

Oxidative catalytic converters, as installed in modern wood stoves, are very effective at reducing emissions of carbon monoxide and hydrocarbons. This is possible, because precious metals like platinum, palladium and rhodium are used on the surface of catalytic converters. These precious metals are distributed very evenly in very small amounts on the surface of catalytic converters. Over the years, the abrasive effect of particles streaming through the catalytic converter will cause the partial diminishing of the coating containing precious metals. Continuous overheating of catalytic converters ($T > 700\text{ °C}$) will damage the coating. In certain cases, the catalytic converter should be replaced and a new converter must be installed to ensure the catalytic effect.

Used catalytic converters are suitable for re-use. Even if they are broken or damaged, they are suitable for recycling.

Contained precious metals can be recovered by thermal or chemical separation techniques to almost 90%, and then used again in the manufacturing process.

Please bring the used catalytic converter to a recycling center.

Thank you very much for your efforts in supporting the protection of environment and sustainable use of resources.

Dimension sheets - BKH flat 42-42 green

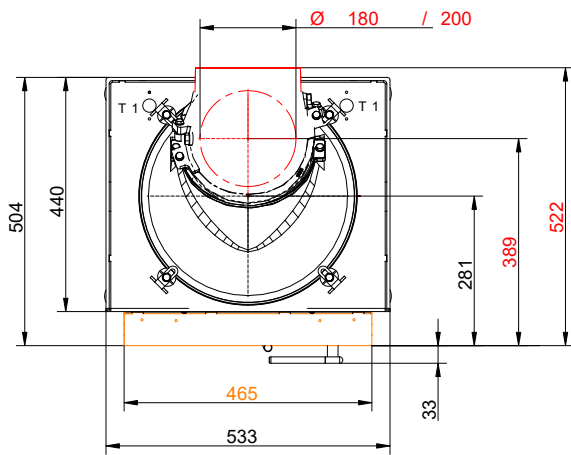
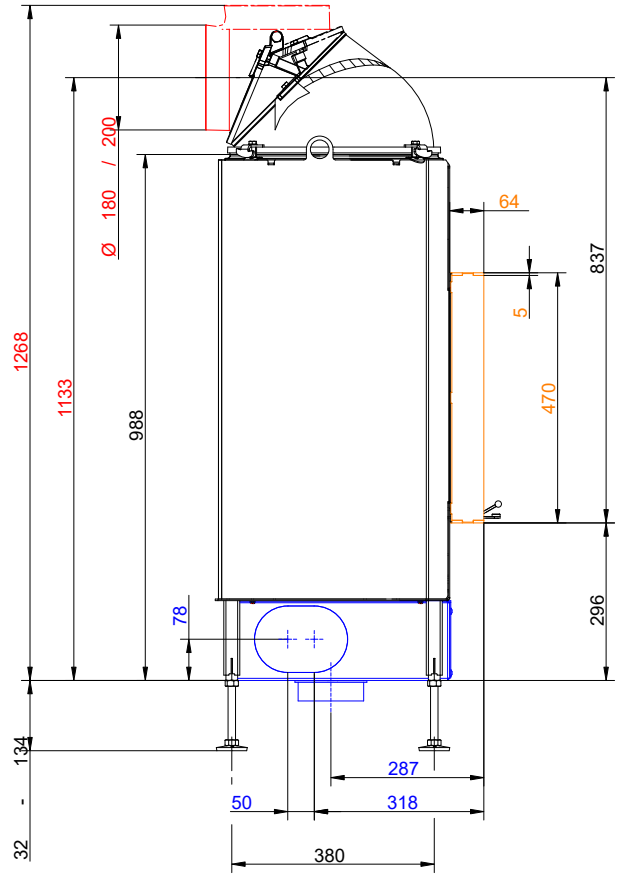
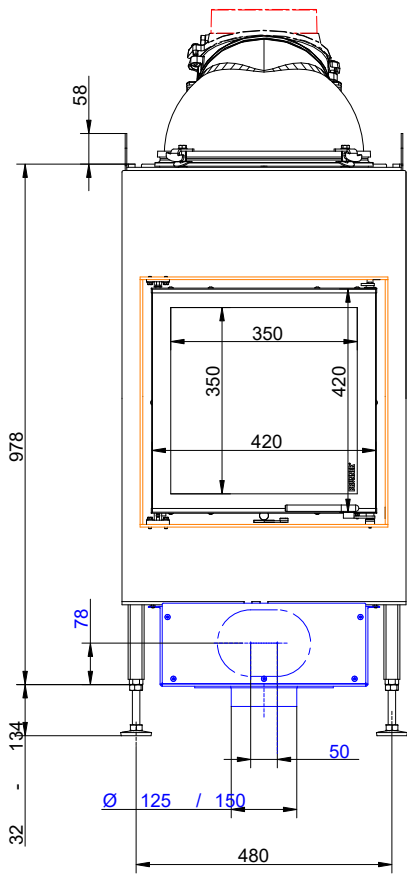

... mounting bracket and cast iron dome

Dimension sheets - BKH flat 42-42 green

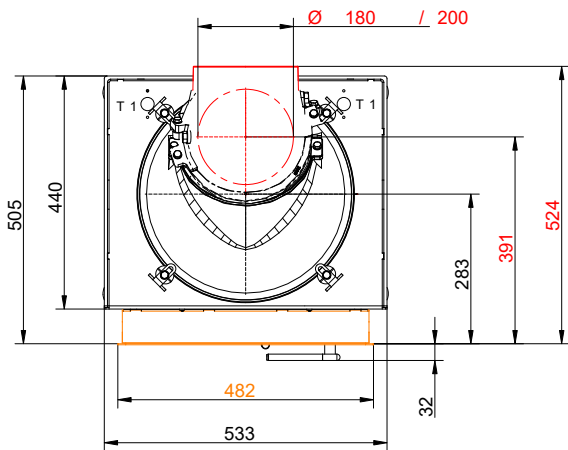
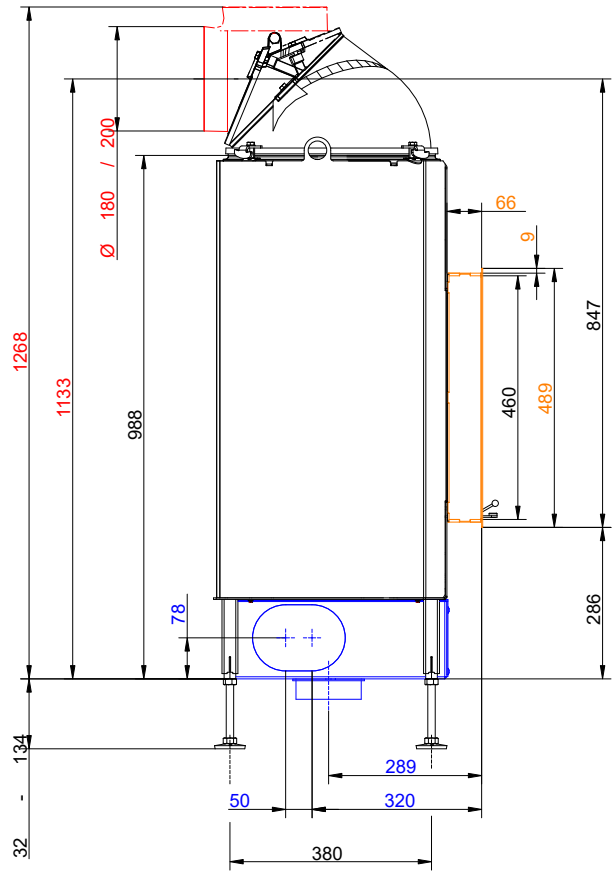
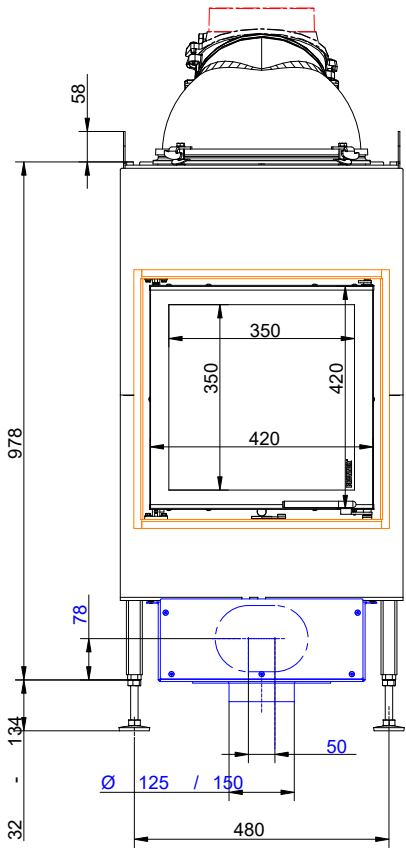

... door frame and cast iron dome

Dimension sheets - BKH flat 42-42 green

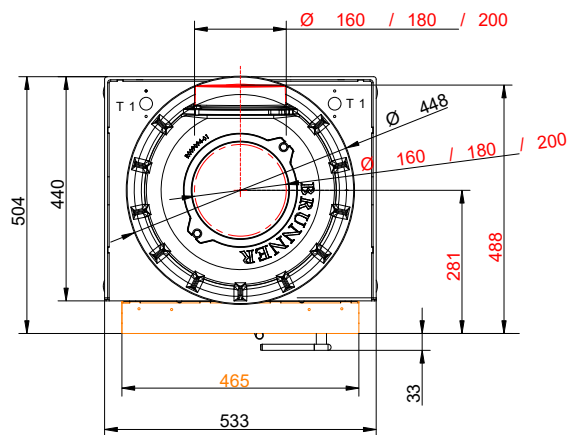
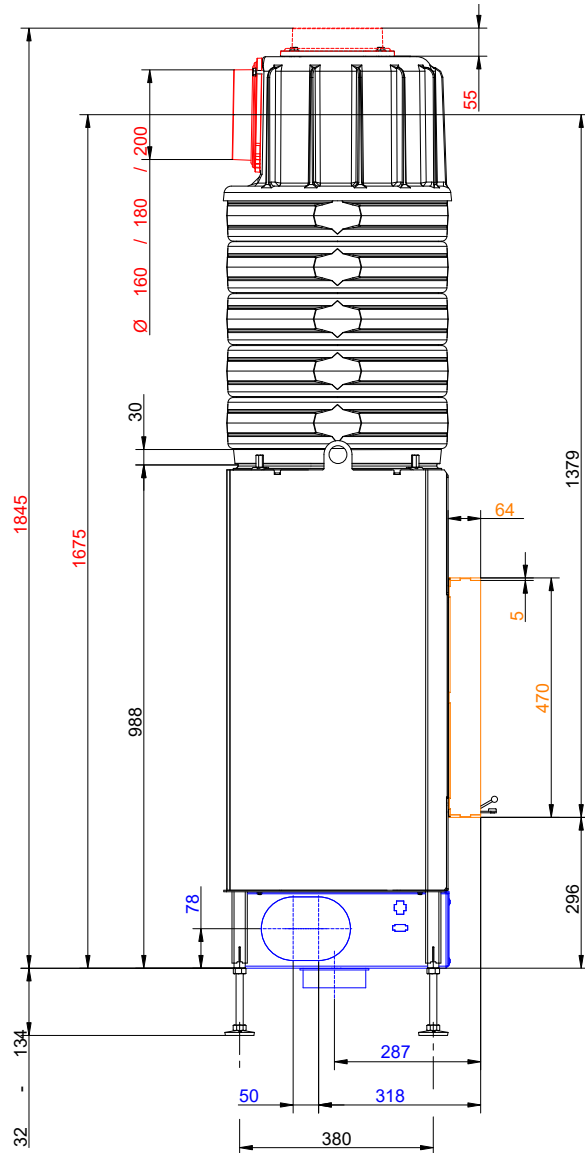
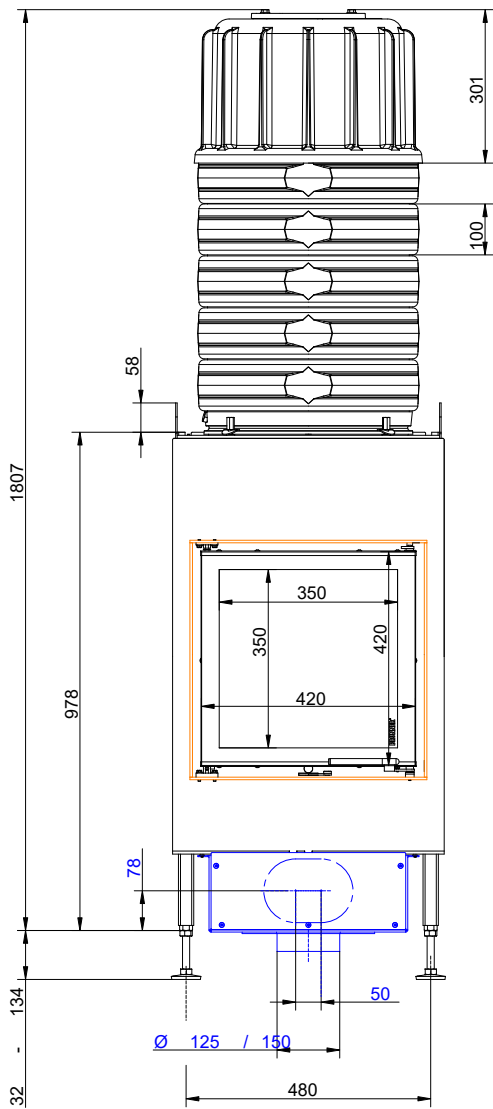

... mounting bracket and MAS

Dimension sheets - BKH flat 42-42 green

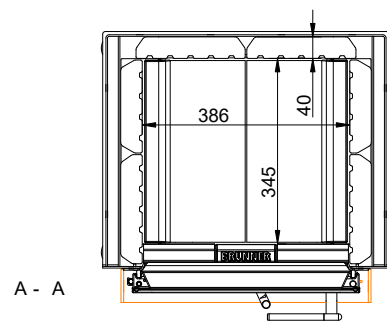
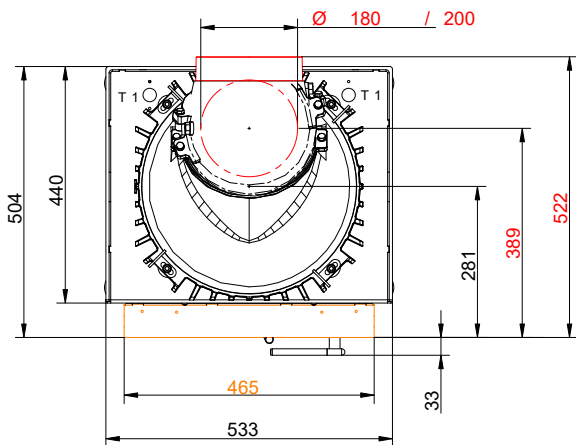
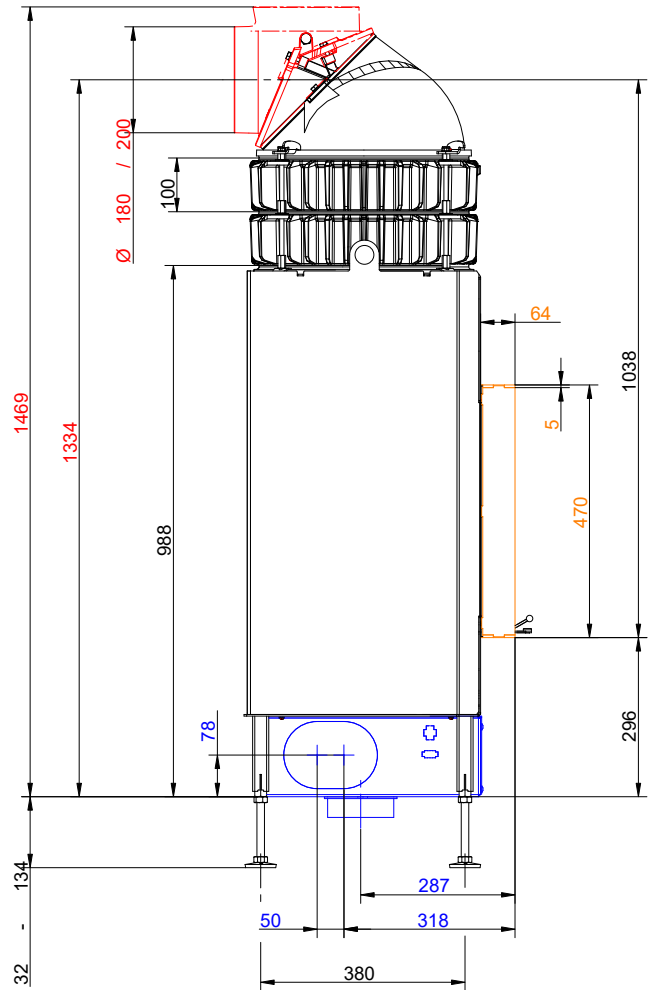
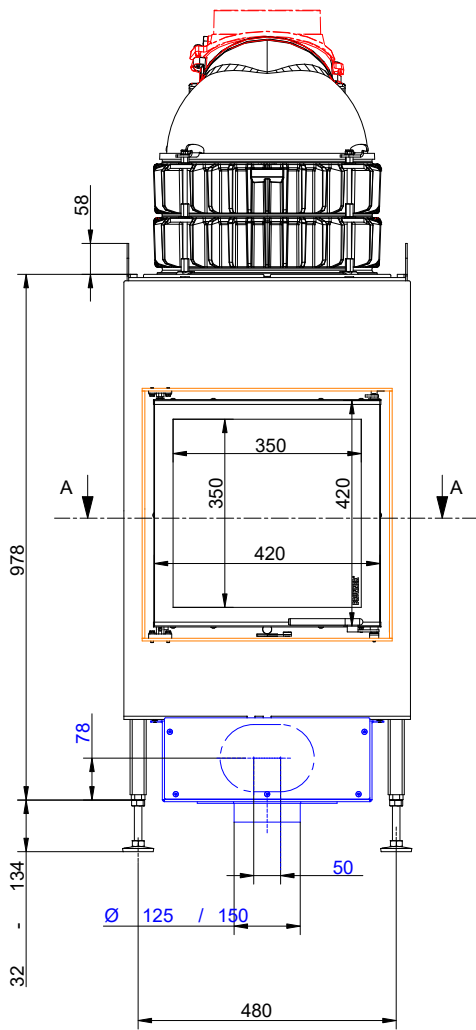

...mounting bracket and cast iron heat exchanger rings + dome

Dimension sheets - BKH flat 42-42 green

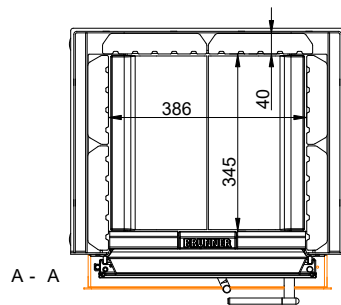
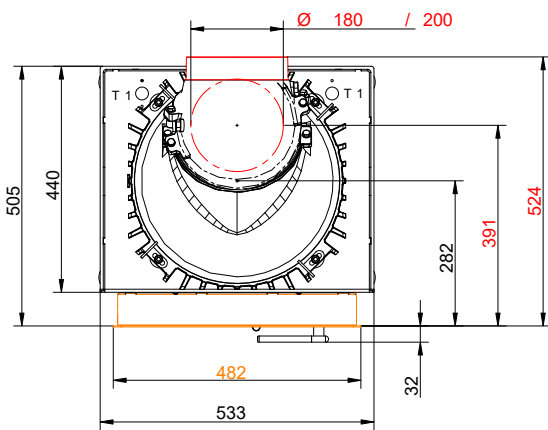
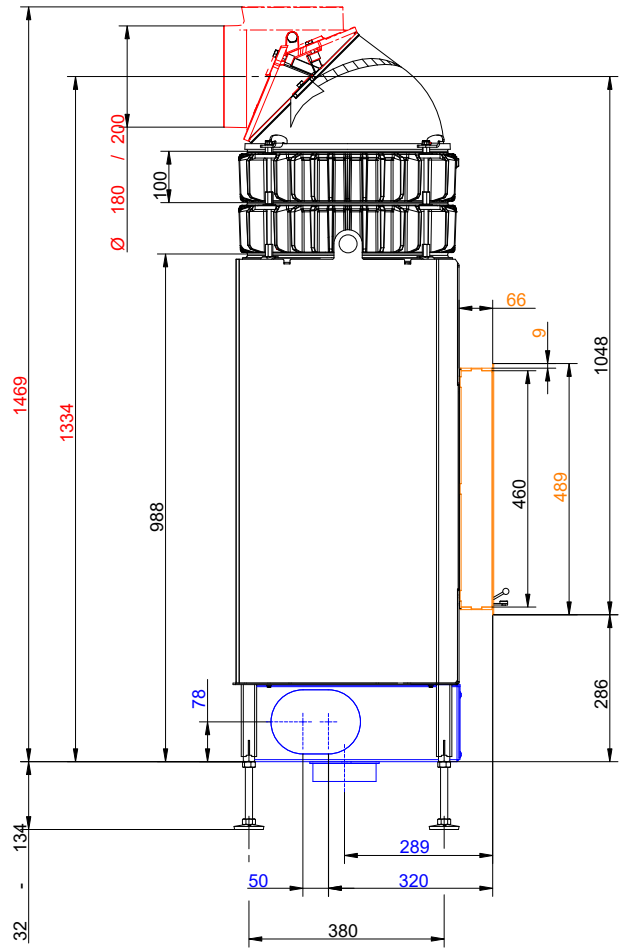
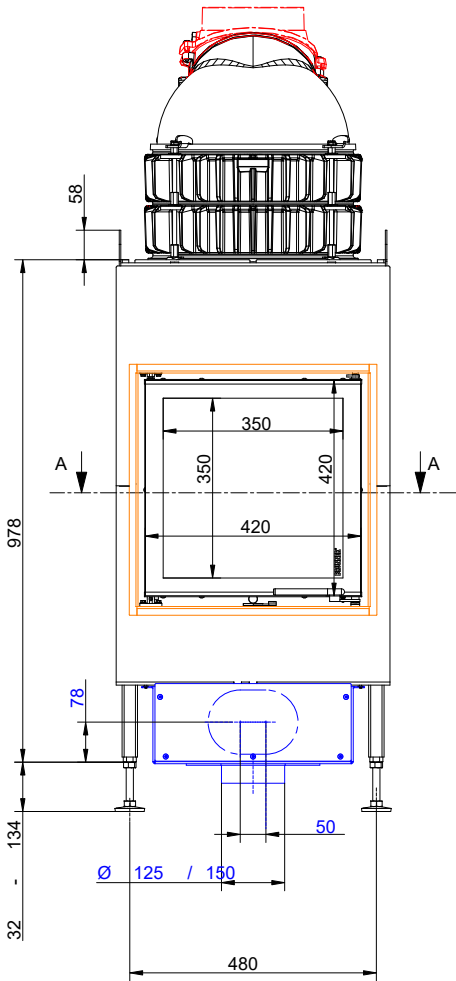

...door frame and cast iron heat exchanger rings + dome

Planning and installation - BKH flat 42-42 green

| Tested according to | | EN 13229 W | EN 13229 WA |
|---|-------------------|---------------------------|---------------------------------|
| Values measured at | | Rated power ¹⁾ | Storage operation ²⁾ |
| Data for functional demonstration | | | |
| Rated heat power | kW | 7 | - |
| Fire wood volume | kg/h | 1.5 | 3.0 |
| Combustion performance | kW | 8.2 | 11 |
| Flue gas mass flow | g/s | 6.6 | 14 |
| Flue gas temperature after: | | | |
| Cast iron dome | °C | 250 | 350 |
| 2 x cast iron heat exchanger rings + dome | °C | 210 | 290 |
| 5 x accumulation rings incl. MAS casted cover ³⁾ | °C | - | 260 |
| 2,0 m ceramic accumulator ⁴⁾ | °C | - | 180 |
| 1,4 m accumulation stones (MSS) ⁴⁾ | °C | - | 180 |
| Boiler module | °C | 208 | - |
| Necessary supply pressure | Pa | 12 | 12 |
| Fuel amount | kg | 1.5 | 3.0 |
| Combustion air consumption | m ³ /h | 18 | 31 |
| Combustion air connection Ø | mm | 125 | 125 |
| Heat distribution | | | |
| Insert / reheating surface | % | 30 / 30 | 30 / 30 |
| glass ceramic / glass ceramic coated (GKB) | % | 40 / 30 | 40 / 30 |
| Cross-section of gratings ⁵⁾ | | | |
| exhaust warm air | cm ² | 600 | 600 |
| Recirculation air | cm ² | 600 | 600 |
| Minimal oven surface for closed construction type | | | |
| Heat dissipating surface | m ² | 3.5 | 3.5 |
| Minimal distances of the fireplace | | | |
| Heat protection panel for cladding, insulation layer | cm | 3 | 3 |
| to cladding, insulation layer | cm | 5 | 5 |
| to the floor (non-combustible) | cm | 3 | 3 |
| Fire protection with active rear ventilation, intermediate space | | | |
| Minimum insulation thickness for construction : insulation material 5 cm rear active ventilation wall ⁶⁾ | | | |
| for mounting wall (combustible/non-combustible) | cm | 5 | 5 |
| Minimum insulation thickness for construction: insulation material 30 cm closed gap ceiling ⁷⁾ | | | |
| for ceiling (combustible) | cm | 10 | 10 |
| Fire protection with adequate insulation material | | | |
| Minimum insulation thickness for construction: insulation material mounting wall, ceiling, floor ⁷⁾ | | | |
| with heat protection panel, mounting wall (non-combustible) ⁸⁾ | cm | 6 | 6 |
| with heat protection panel, mounting wall (combustible) ⁸⁾ | cm | 12 | 12 |
| Mounting wall (non-combustible) | cm | 8 | 8 |
| Mounting wall (combustible) | cm | 18 | 18 |
| Ceiling (non-combustible) | cm | 8 | 8 |
| Ceiling (combustible) | cm | 22 | 22 |
| Floor (non-combustible) | cm | 0 | 0 |
| Minimum distances in front of the combustion chamber, glass ceramic / glass ceramic coated (GKB) | | | |
| for combustible parts | cm | ≥ 120 / ≥ 80 | ≥ 120 / ≥ 80 |
| Weight | | | |
| Fireplace insert + combustion chamber inner lining chamotte/cast iron | kg | 93 + 65 / 79 | |

Planning and installation - BKH flat 42-42 green

Meets requirement/limit values for:

EU / Germany

Ecodesign / 1. BImSchV (Stufe 2)

- 1) Indications to "Rated power" determined with 2 heat exchanger rings made of cast iron and Ø180 dome.
- 2) Indications to "Storage operation" for the manual execution of the reheating surface (guide values).
- 3) Damper flap recommended
- 4) Standard value or calculated functional proof required.
- 5) Air cross-sections if the specified nominal heat output is desired as the heat output.
- 6) Fire safety: Values determined with air cross-sections recorded for testing purposes; active rear ventilation, stove shell is heat emitting.
Insulation thickness 5 cm calcium silicate board (brands: Promasil, Silka, Skamol) and 5 cm active rear ventilation with diagonally positioned air circulation and supply air openings of 75 cm² (5x15 cm) each. For detailed design, see assembly instructions.
- 7) Fire safety: values determined in safety test with air cross-sections recorded for testing purposes; stove shell is heat emitting.
Information on replacement insulation material with calcium silicate boards (brands: Promasil, Silka, Skamol).
The specifications for non-combustible walls/ceilings and the structure with a closed gap (30 cm) correspond to the specifications of TROL (Germany), see assembly instructions.
- 8) Heat protection plate: accessory for BKH flat/tunnel/corner versions; factory-fitted for BKH panoramic fireplaces.

Product data sheet according to (EU) 2015/1186:

| | |
|---|------------------------------|
| Supplier's name or trademark | Ulrich Brunner GmbH |
| Model identifier: | BKH 5.0 Flach 42-42 green DT |
| Energy efficiency class: | A+ |
| Direct heat output: | 7,0 kW |
| Indirect heat output: | N.A. kW |
| Energy efficiency index: | 115,7 |
| Fuel energy efficiency (at nominal heat output): | 87,0 % |
| Fuel energy efficiency (at minimum load): | N.A. % |
| Special precautions: see supplied product documentation | |

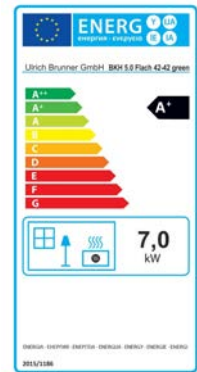
**Ulrich Brunner GmbH**

Zellhuber Ring 17-18

D-84307 Eggenfelden

Phone: +49 (0) 8721/771-800

E-Mail: info@brunner.de**Copyright**

All information, drawings and technical descriptions contained in this documentation are our property and may not be reproduced without prior written permission.

® **BRUNNER** is a registered trademark.

Subject to technical changes and errors.

© by Ulrich Brunner GmbH

Doku-Nr.: 203008