

Installation Manual

BKH 5.0 Eck/corner
42-42-42

green

©2025

BRUNNER®

CONTENTS

1	Basic informations.....	4
1.1	Specified symbols.....	4
2	Safety.....	5
2.1	Safety precautions.....	5
2.2	Fire protection.....	7
2.2.1	Mounting wall / Ceiling non-combustible.....	8
2.2.2	Mounting wall / Ceiling combustible (U-value > 0,4 W/m ² K).....	9
2.2.3	Mounting wall / Ceiling combustible (U-value < 0,4 W/m ² K).....	12
3	Delivery contents BKH Eck/corner 42-42-42.....	13
3.1	Catalytic converter (optional).....	14
4	Installation.....	16
4.1	Instructions BKH accessories & additional options.....	16
4.2	Setting up.....	19
4.2.1	Remove the transport locks.....	19
4.2.1.1	Variant BKH Eck/corner DT (side-opening door).....	19
4.3	Fitting: catalytic converter.....	20
4.4	Fitting: deflection - combustion chamber.....	24
4.5	Variants Combustion chamber lining.....	25
4.5.1	Chamotte inner lining.....	25
4.6	Variants heat exchanger.....	26
4.6.1	Connection with catalytic converter.....	26
4.6.2	Connection without catalytic converter.....	27
4.6.3	Cast iron dome.....	33
4.6.3.1	Components Cast iron dome.....	33
4.6.3.2	Cast iron dome.....	33
4.6.3.3	Additional option : Heat exchanger rings.....	37
4.6.3.3.1	Components Heat exchanger rings.....	37
4.6.3.3.2	Heat exchanger rings.....	37
4.6.4	MAS.....	43
4.6.4.1	Components MAS modular top-mount storage SET 440.....	43
4.6.4.2	Heat exchanger MAS.....	44
4.7	Variant: EOS.....	50
4.7.1	Bottom cover air box EOS.....	50
4.7.1.1	Components EOS.....	50
4.7.1.2	Fitting: EOS.....	51
4.7.1.3	Membrane feed-through.....	52
4.7.1.4	Air position indicator.....	53
4.7.2	Thermocouple.....	54
4.7.2.1	Components Thermocouple.....	54
4.7.2.2	Fitting: Thermocouple.....	54
4.7.3	Door contact switch.....	56
4.7.3.1	Components Door contact switch.....	56
4.7.3.2	Einbau Door contact switch.....	57

5	Frame variants	58
	5.1 Door frame (BKH with side-opening door).....	59
6	Conversions, settings	61
	6.1 Adjusting of self-closing door.....	61
7	Disposal	66
8	Technical data	67

1 BASIC INFORMATIONS



All instructions delivered with products must be observed. We do not accept any warranty claim or liability for damage resulting from failure to observe these installation instructions!
Improper installation can cause injury and material damage!

The floor space of the room must have a suitable structure and sufficient dimensions to ensure proper functioning of the fireplace.

Please note that other installation and assembly instructions are included in other packaging units!

Dimensioning of downstream heat accumulator must be according to valid stove-setting rules.

During installation of the fireplace, all dimensions and minimal clearances of the fireplace casing must be held as specified by the manufacturer.

All binding national or EU standards and local regulations for the installation of fireplaces must be observed.

All valid stove fitting rules and regulations of local construction law must be observed and followed.

Please follow the relevant regulations of your country.

When these instructions are followed and all works are done properly, this will ensure a safe, energy-saving and environmentally friendly operation of the stove. Pictures shown are not to be considered as complete representations of any kind.

Subject to technical and assortment changes.

Please notify your supplier of any damage which might have occurred during transport.

Please keep these instructions.

Please also take note of the online product documentation provided by:



[General instructions of the Brunner products installation for the stove construction.](https://www.brunner.de/produktdownloads/kachelofen-kamine/allgemeine-hinweise-fuer-den-aufbau_de.pdf)

(https://www.brunner.de/produktdownloads/kachelofen-kamine/allgemeine-hinweise-fuer-den-aufbau_de.pdf) laden können.



1.1 SPECIFIED SYMBOLS

In this documentation, a distinction is made between:

Operating personnel as the **User of the system**, i.e. the end user, which has received instructions from the Contractor and does not necessarily have additional qualifications.

Operating personnel as the **Contractor**, i.e. the qualified professionals, which are entitled to perform the indicated specialist works.

In this document, the following symbols are used:

**DANGER**

A danger of high risk persists, which leads to severe injury or death, if this endangering situation is not avoided.

WARNING

A danger of medium risk persists, which can lead to severe injury or death, if this endangering situation is not avoided.

CAUTION

A danger of low risk persists, which can lead to minor or moderate injury, if this endangering situation is not avoided.

**ATTENTION**

There is a certain risk, which can lead to a malfunction or damage of the related system and all devices connected with it, if the indicated notifications are not followed.

**NOTE**

Additional helpful information

2 SAFETY

2.1 SAFETY PRECAUTIONS

Fireplaces may be set up only in rooms or areas with no risk of danger due to their location, structure or intended use.

Working on the stove

Installation, commissioning, servicing and maintenance works on the product may be carried out only by an authorized stove-fitter. Safety and efficiency of the system depend on this!

Working with electronics

Switch off the emergency switch or circuit breaker, and secure them against switching on again.



Fireplaces with external air supply are not independent from room air supply and must be considered and designed as roomsealed fireplaces. In connection with a ventilation or extraction system, we recommend the use of a negative pressure safety device (Art.No.: 11600.1).

Installation must be carried out by an authorized stove-fitter, because safety and efficiency of the system depend mostly on proper installation of the product. All valid stove fitting rules and regulations of building law must be observed and followed. Make sure to instruct the owner or user about the functions and controls of the system and possibly installed safety devices.

Fireplaces must be built to ensure safe operation and fire safety in order to eliminate possible risks and unacceptable loads. They have to be ready for use over an adequate period of time.

Make sure to instruct the owner or user about the functions and controls of the system and possibly installed safety devices.

Remember to use only genuine replacement parts.

2.2 FIRE PROTECTION

The thermal insulation listed in the fire protection information is implemented with substitute insulation material in the form of calcium silicate boards (e.g. brands: Promasil, Silka, Skamol).

If a different insulating material is used (e.g. vermiculite), the manufacturer's specifications must be used for conversion to the installed insulating material.

The thermal insulation for non-combustible add-on walls and ceilings is based on the requirements of TROL (Germany).

For extension walls made of combustible building materials, fire protection can also be provided in a version with active rear ventilation. This variant has been tested and is created with an insulation thickness of 5 cm. It is important to ensure that air flows across the entire width and height.

The room air must be able to flow in at the bottom and out at the top. The air inlet and outlet openings (cross-section 75 cm²) must not be sealable. In normal operation, the temperatures at the air outlet are below 85°C.

For thermally insulated add-on walls with a U-value < 0.4 W/m²K, the fire protection must be designed with active rear ventilation.

2.2.1 MOUNTING WALL / CEILING NON-COMBUSTIBLE

Structure: Substitute insulation material | Mounting wall / Ceiling non-combustible

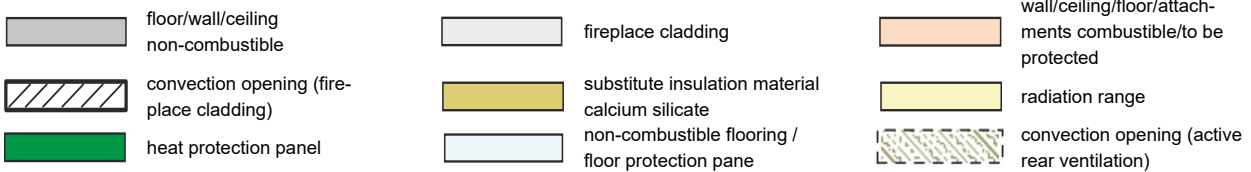
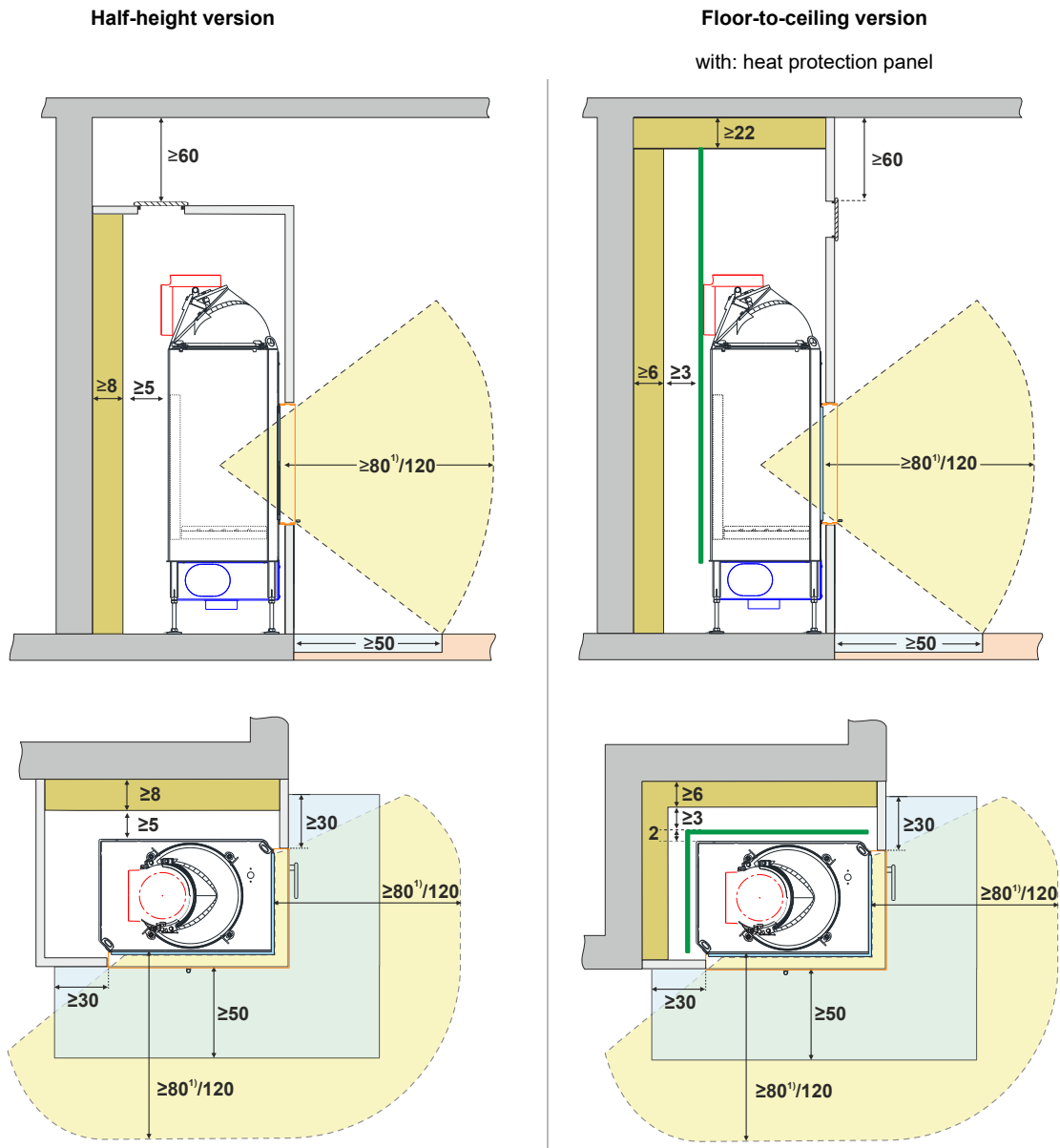

¹⁾ Glass ceramic coated (GKB)

All figures in cm

When designing the exhaust system and exhaust pipe, national standards and fire protection regulations must be observed

2.2.2 MOUNTING WALL / CEILING COMBUSTIBLE (U-VALUE > 0,4 W/M²K)

Structure: Substitute insulation material I Mounting wall / Ceiling combustible

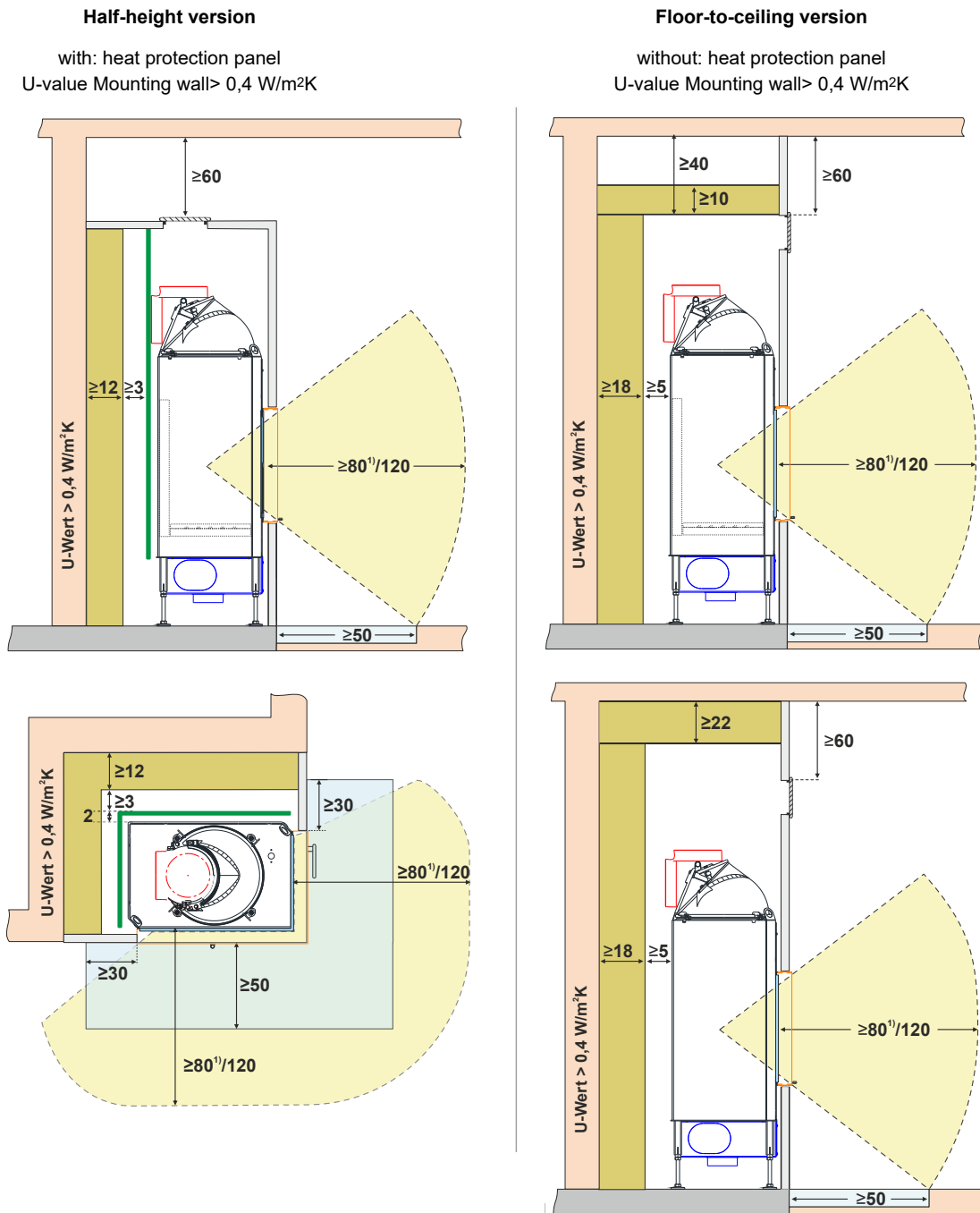

¹⁾ Glass ceramic coated (GKB)

All figures in cm

When designing the exhaust system and exhaust pipe, national standards and fire protection regulations must be observed

Structure: Substitute insulation material | active rear ventilation | Mounting wall/ Ceiling combustible

Half-height version



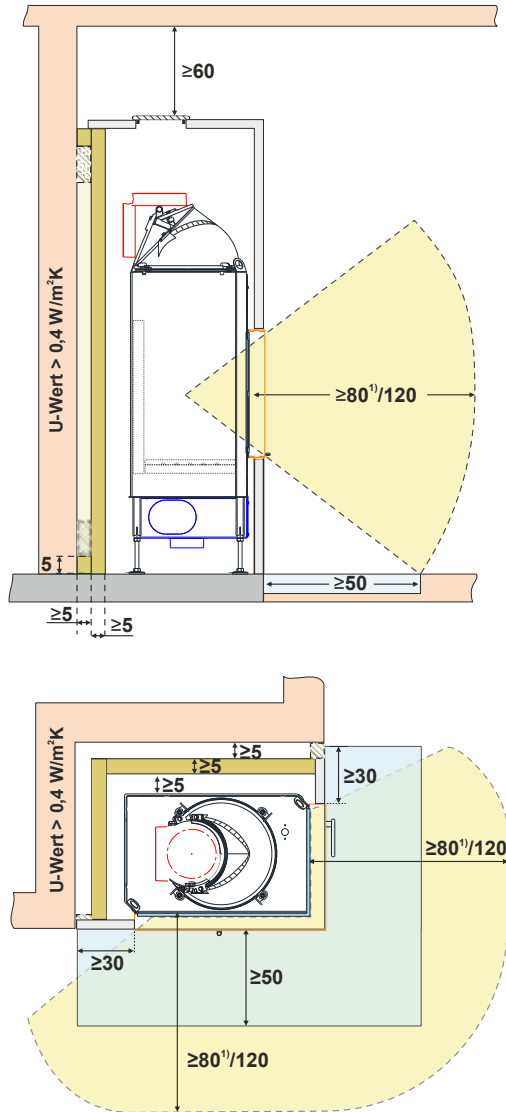



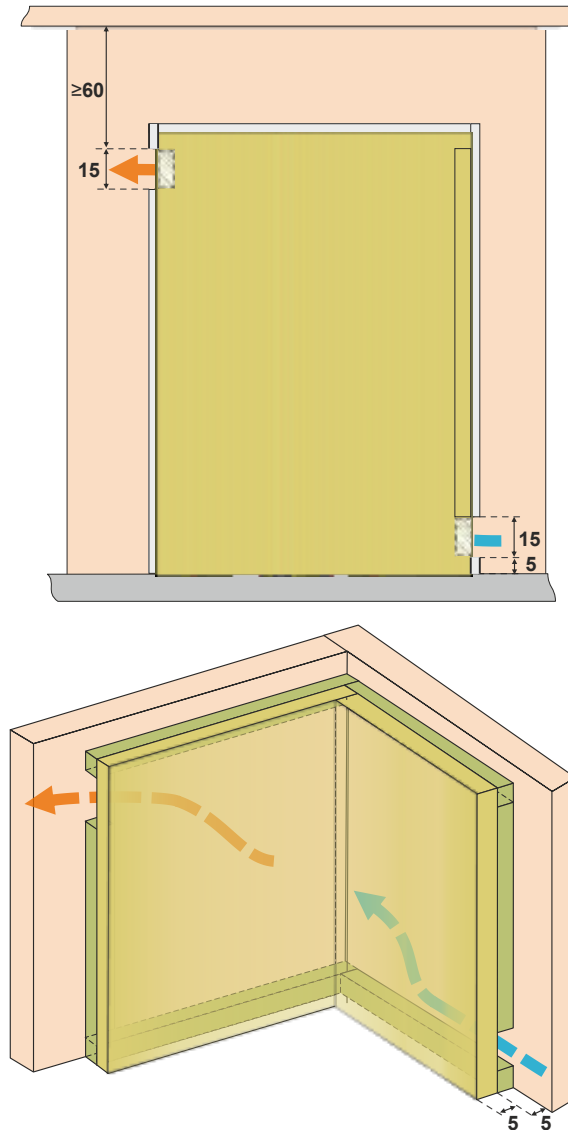

with: active rear ventilation
U-wert Mounting wall > 0,4 W/m²K

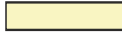

Detail:

active rear ventilation (2x75 cm²)



- | | | | | | |
|---|--|---|---|---|--|
|  | floor/wall/ceiling
non-combustible |  | fireplace cladding |  | wall/ceiling/floor/attach-
ments combustible/to be
protected |
|  | convection opening (fire-
place cladding) |  | substitute insulation material
calcium silicate |  | radiation range |
|  | heat protection panel |  | non-combustible flooring /
floor protection pane |  | convection opening (active
rear ventilation) |

¹⁾ Glass ceramic coated (GKB)

All figures in cm

When designing the exhaust system and exhaust pipe, national standards and fire protection regulations must be observed

Structure: Substitute insulation material I aktive Hinterlüftung I Mounting wall/ Ceiling combustible







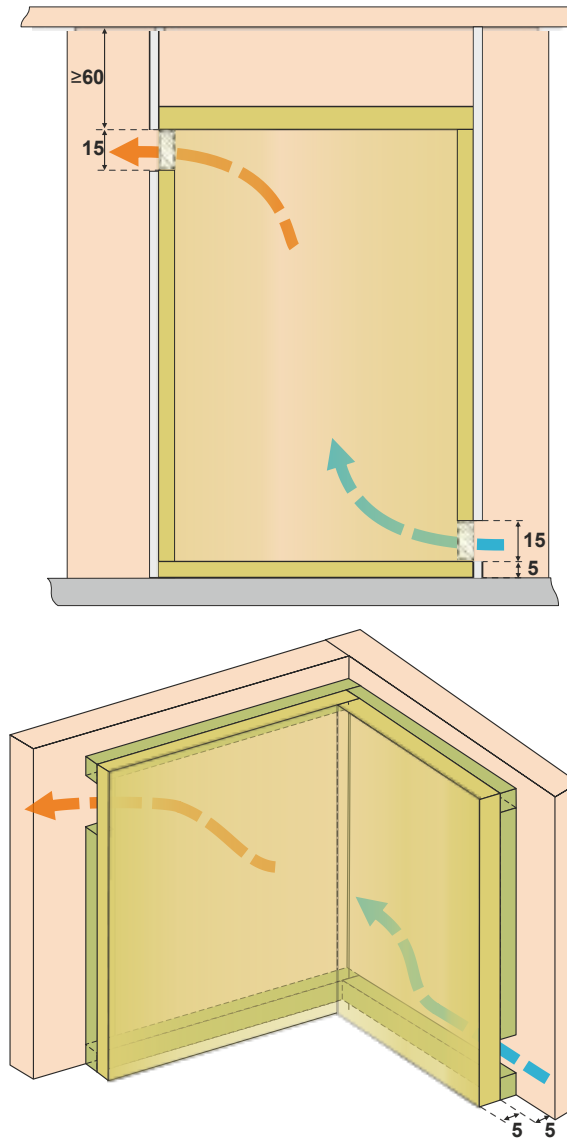
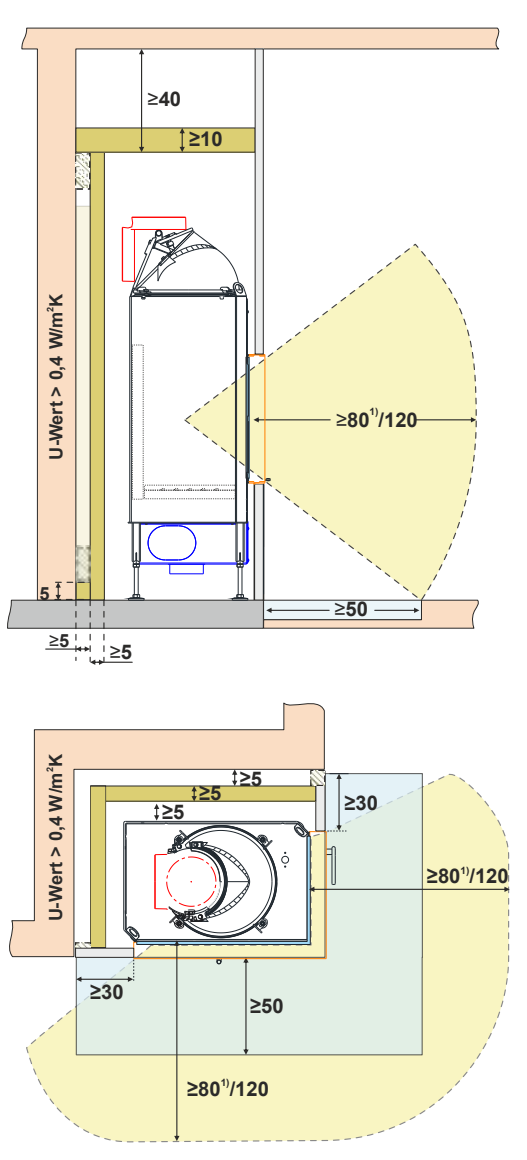

Floor-to-ceiling version

with: active rear ventilation
U-value Mounting wall > 0,4 W/m²K

Detail:

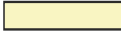
active rear ventilation (2x75 cm²)



- | | | |
|---|--|--|
|  floor/wall/ceiling non-combustible |  fireplace cladding |  wall/ceiling/floor/attachments combustible/to be protected |
|  convection opening (fireplace cladding) |  substitute insulation material calcium silicate |  radiation range |
|  heat protection panel |  non-combustible flooring / floor protection pane |  convection opening (active rear ventilation) |

¹) Glass ceramic coated (GKB)

All figures in cm

When designing the exhaust system and exhaust pipe, national standards and fire protection regulations must be observed

3 DELIVERY CONTENTS BKH ECK/CORNER 42-42-42

BKH Eck/corner 42-42-42 with side-opening door (DT)

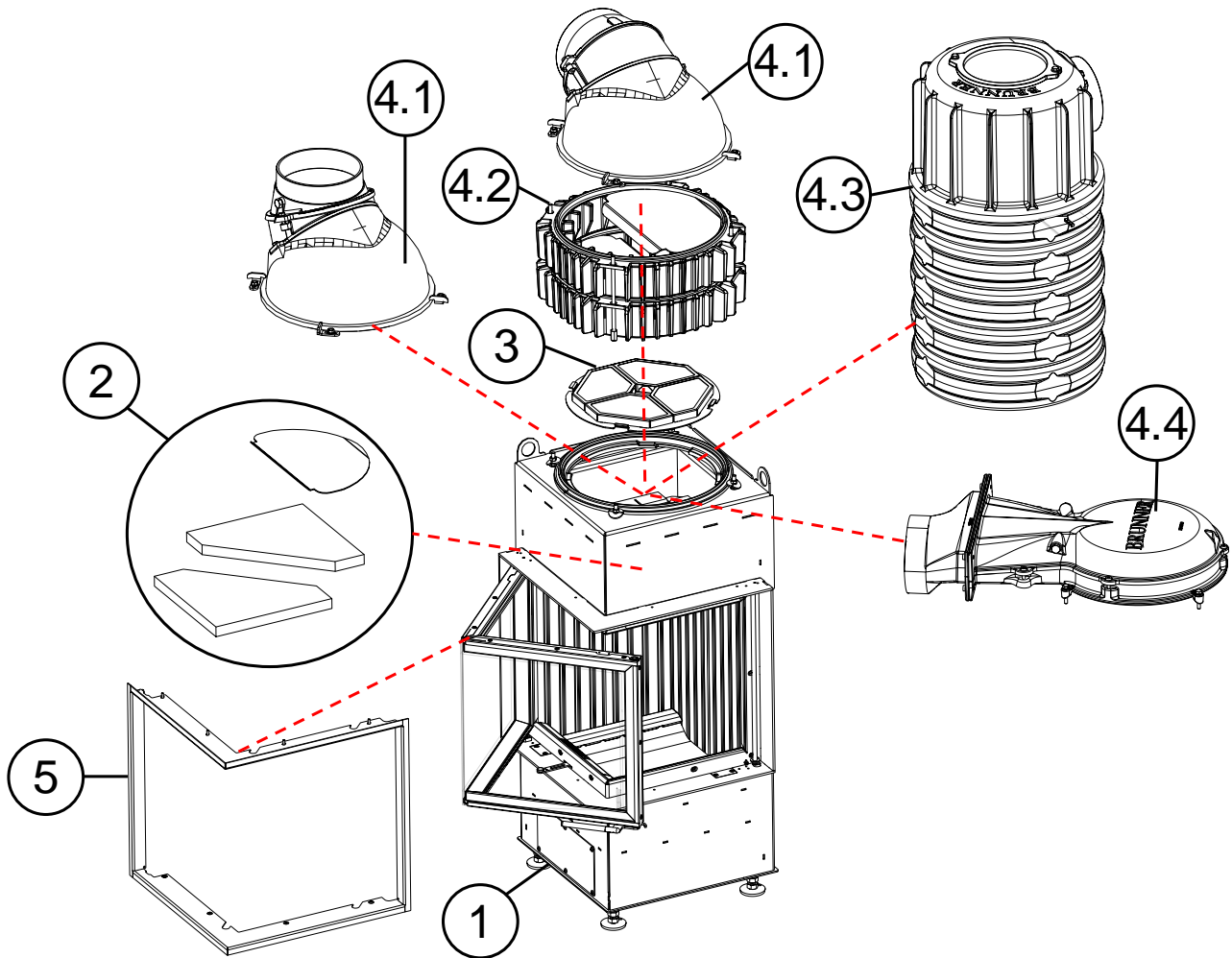

Pos.	Designation	Art. No.
1	BKH - variants:	
	BKH 5.0 Eck/corner 42-42-42 DT with manual operation, with Ceramic glass (GK) Chamotte inner lining (FR)	HK019002-01
	BKH 5.0 Eck/corner 42-42-42 DT with manual operation, with Glass ceramic coated (GKB) Chamotte inner lining (FR)	HK019002-05
	BKH 5.0 Eck/corner 42-42-42 DT for EAS/EOS with Ceramic glass (GK) Chamotte inner lining (FR)	HK019002-02
	BKH 5.0 Eck/corner 42-42-42 DT for EAS/EOS with Glass ceramic coated (GKB) Chamotte inner lining (FR)	HK019002-06
	BKH 5.0 Eck/corner 42-42-42 DT with manual operation, with Ceramic glass (GK) Cast iron inner lining (FR/Guss)	HK019002-03
	BKH 5.0 Eck/corner 42-42-42 DT with manual operation, with Glass ceramic coated (GKB) Cast iron inner lining (FR/Guss)	HK019002-07
	BKH 5.0 Eck/corner 42-42-42 DT for EAS/EOS with Ceramic glass (GK) Cast iron inner lining (FR/Guss)	HK019002-04
	BKH 5.0 Eck/corner 42-42-42 DT for EAS/EOS with Glass ceramic coated (GKB) Cast iron inner lining (FR/Guss)	HK019002-08
2	The non-installed parts (e.g. deflection plates, control levers, etc.) and any accessories ordered (e.g. catalytic converter, packaging with EOS, etc.), including the instructions box, are packed in the combustion chamber	
3	Catalyst module BKH 5.0	HK000210
Smoke hood variants		
4.1	Rotating cast iron dome with adjustable connecting piece \varnothing 180 mm	D004186
	Rotating cast iron dome with connecting piece $d=200$ mm	10087
4.2	with heat exchanger rings	R015006-02
4.3	Connection variant MAS SET440	SET211444
4.4	Cast iron dome low	D016042
Additional options:		
5	Door frame, black	HK019150-01

3.1 CATALYTIC CONVERTER (OPTIONAL)



The catalytic converters are coated with a catalytically active layer. This coating can consist of mixed metal oxides or also of precious metals. In order not to limit the effect of this catalytically active layer, the catalysts may only be handled with gloves, preferably with disposable gloves.

In order not to limit the effect of this catalytically active layer, the catalysts may only be handled with gloves, preferably with disposable gloves.



**ATTENTION**

The catalysts are fragile and must only be handled with care. Avoid bumping and do not drop the catalytic converter. This could destroy the catalytic converter!

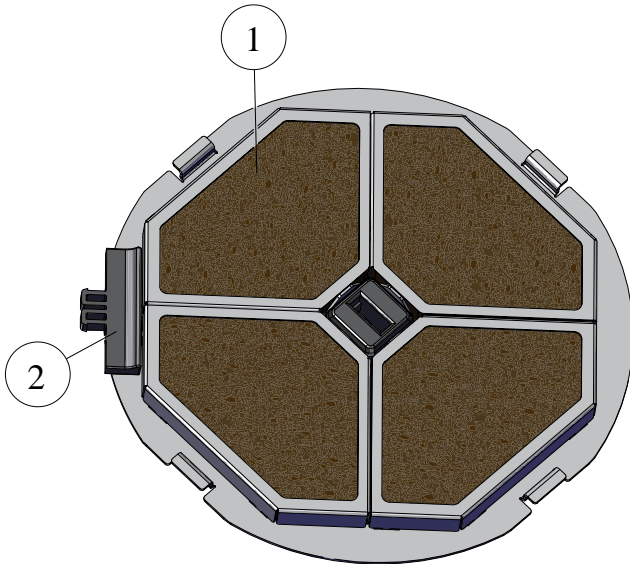

1	catalytic converter
2	assembly tool

**Note**

This catalytic converter is suitable for all BKH units (with lifting door, with side opening door, tunnel, with cast dome, with heat exchanger cast rings and MAS).

This catalytic converter can also be retrofitted.

4 INSTALLATION

4.1 INSTRUCTIONS BKH ACCESSORIES & ADDITIONAL OPTIONS

The instructions for installing the respective accessories and additional options are available via the following QR codes.

Heat exchanger rings

for:



BKH flat
BKH corner
BKH Tunnel

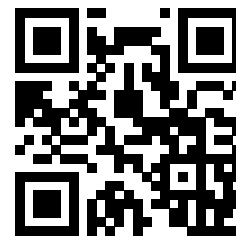

<https://www.brunner.de/21776>

Connection pipe eccentric

for:



BKH flat
BKH corner
BKH Tunnel

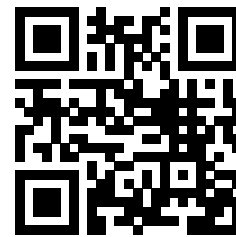

<https://www.brunner.de/21788>

Cast iron dome ø 180 mm low**for:**

BKH flat 42-42
BKH flat 42-50
BKH flat 42-66
BKH Tunnel 42-50
BKH Tunnel 42-66
BKH corner 42-42-42
BKH corner 42-66-42
(DTL & DTR)

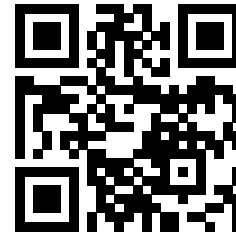

<https://www.brunner.de/23590>

Modular Accumulator MAS**for:**

BKH flat
BKH corner
BKH Tunnel
BKH Panorama

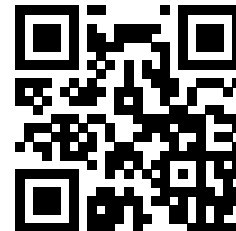

<https://www.brunner.de/22266>

Boiler module**for:**

BKH flat
BKH corner
BKH Tunnel

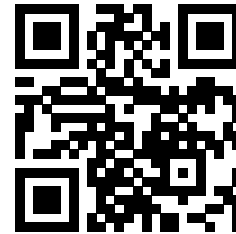

<https://www.brunner.de/23299>

for:**Integrated secondary air device**

BKH flat
BKH corner
BKH Tunnel

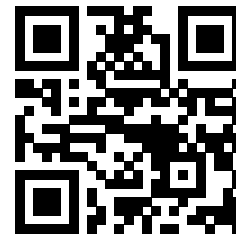

<https://www.brunner.de/23423>

4.2 SETTING UP



DANGER

Possible personal injury and/or property damage caused by improper installation

Assembly and installation of BKH requires extensive specialist knowledge.

- Assembly and installation works must be performed by authorized professionals.



Danger

Risk of injury caused by heavy loads

Carrying of heavy loads can lead to injuries.

- The equipment should be carried by at least two people.
- Use appropriate carrying aids.
- Keep the transport weight in mind.

As long as the device is on the wooden pallet, it can be transported with a hand truck or forklift as usual.

4.2.1 REMOVE THE TRANSPORT LOCKS

4.2.1.1 VARIANT BKH ECK/CORNER DT (SIDE-OPENING DOOR)



NO TRANSPORT LOCK !

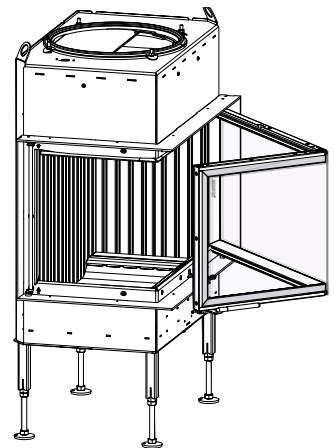

4.3 FITTING: CATALYTIC CONVERTER

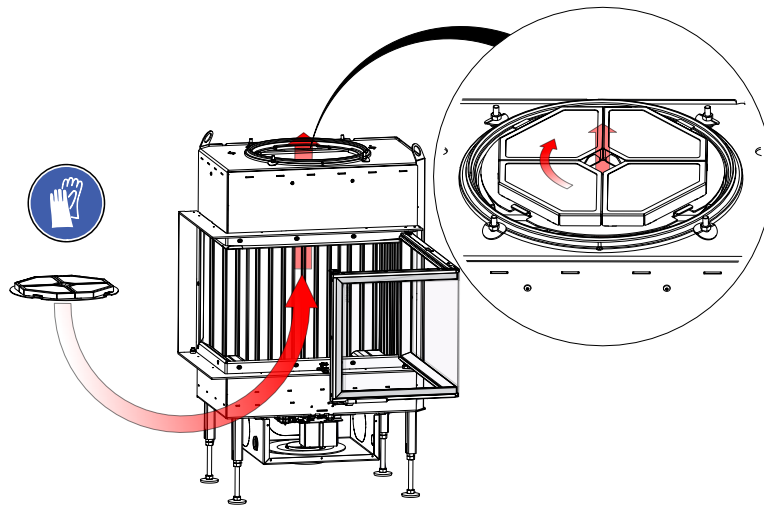

Im. 1: Summarised information

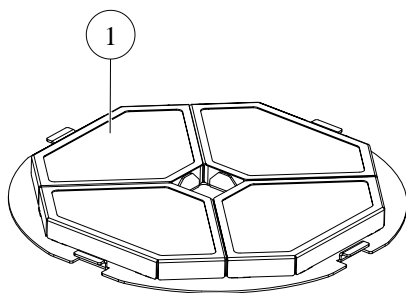

1	catalytic converter
2a+2b	assembly tool

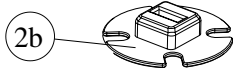
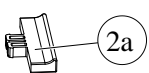

Workflow:

1

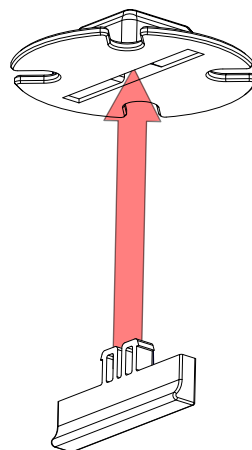

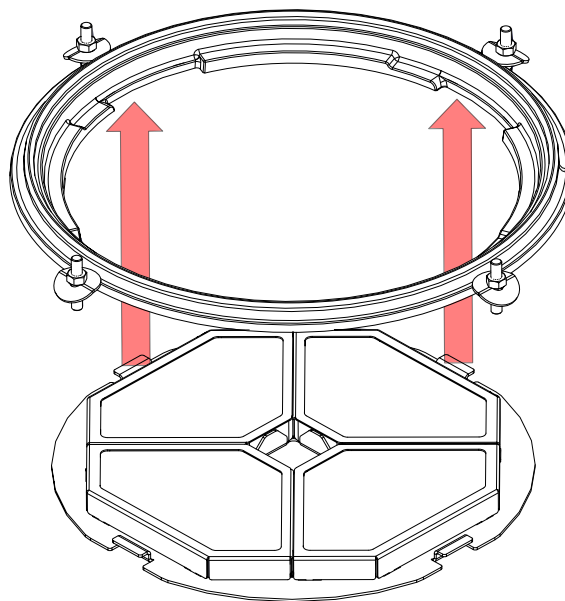
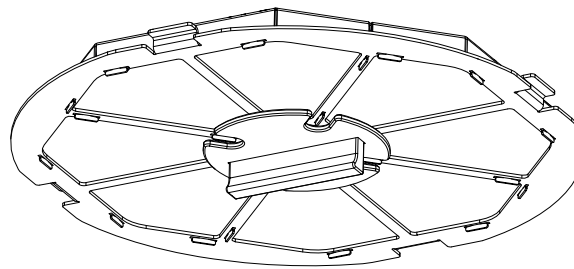
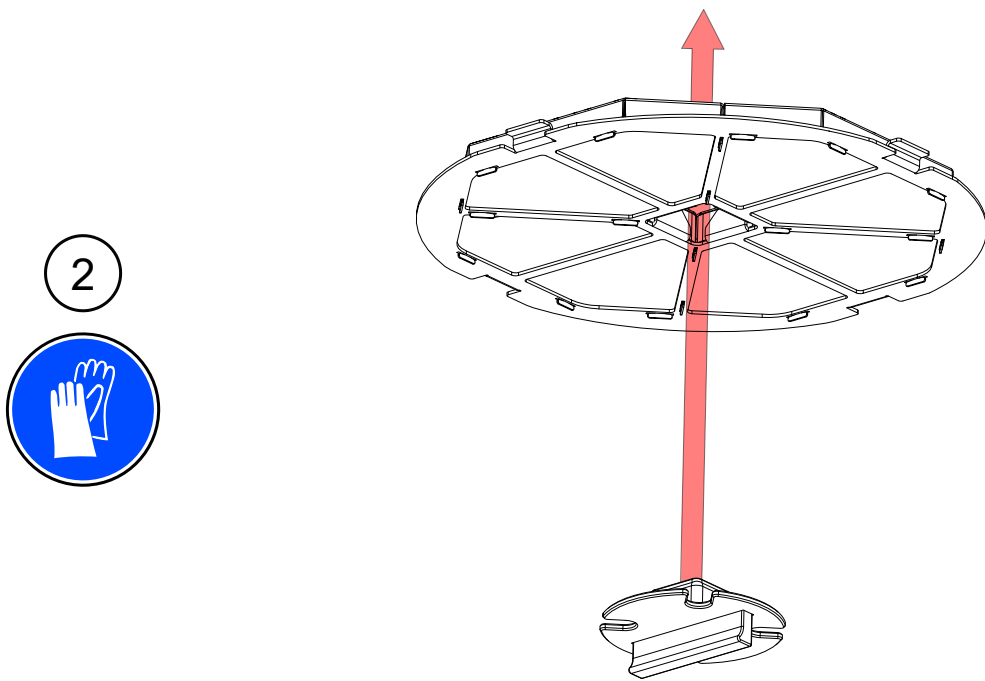



3

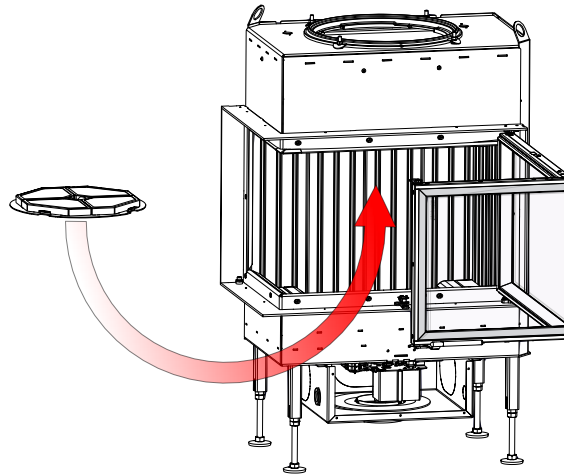

4

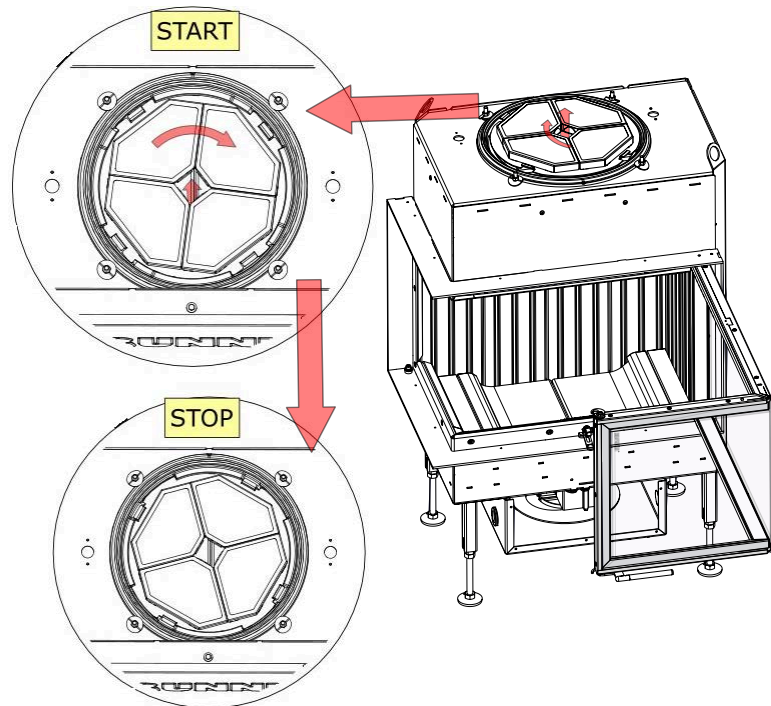

5

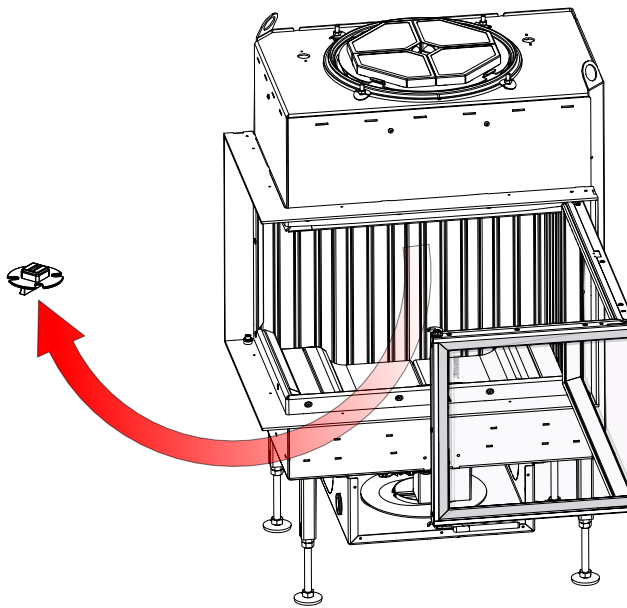

4.4 FITTING: DEFLECTION - COMBUSTION CHAMBER

Summarised information:

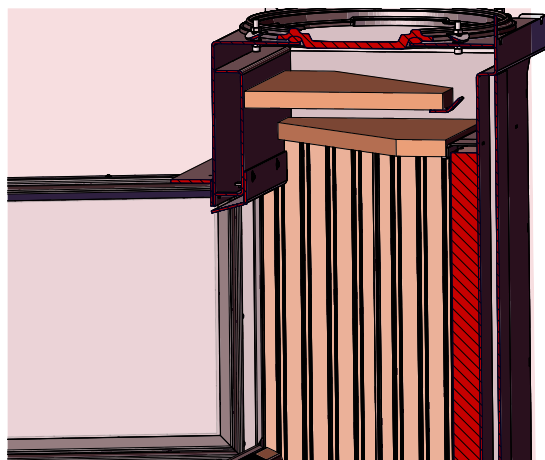
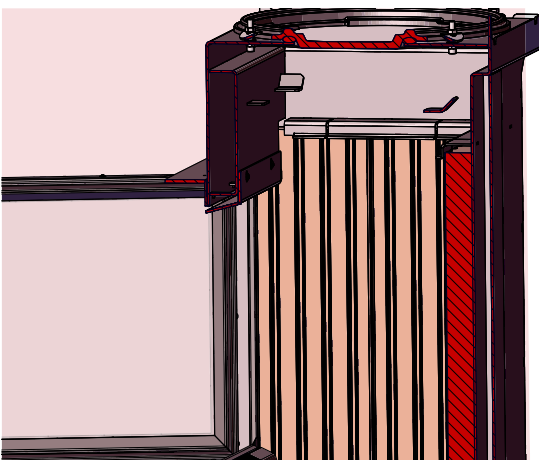
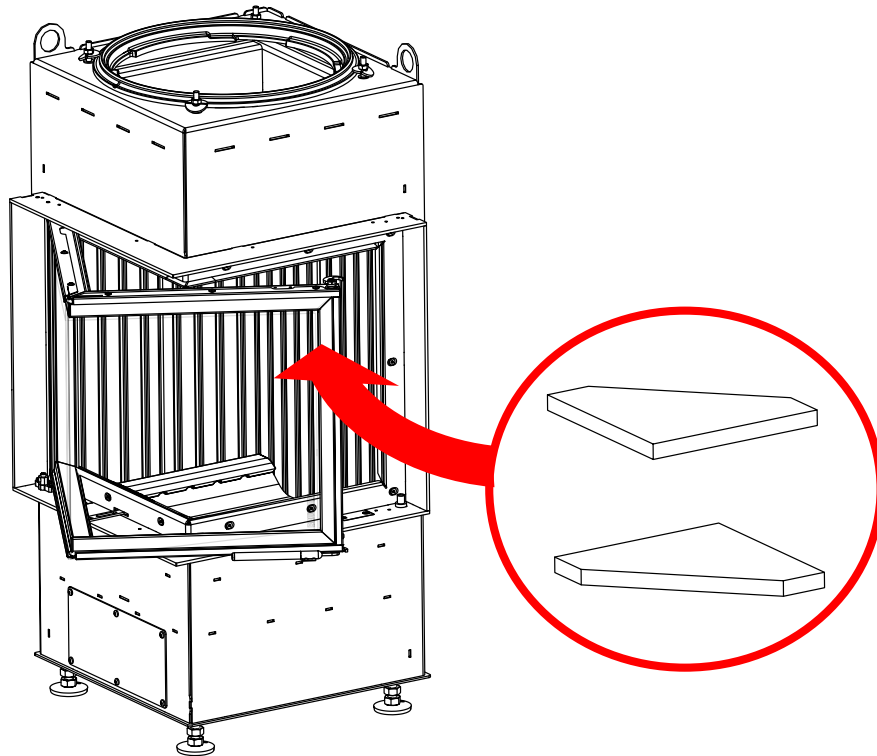

4.5 VARIANTS COMBUSTION CHAMBER LINING

4.5.1 CHAMOTTE INNER LINING

corner 42-42-42 (HK019200-01)

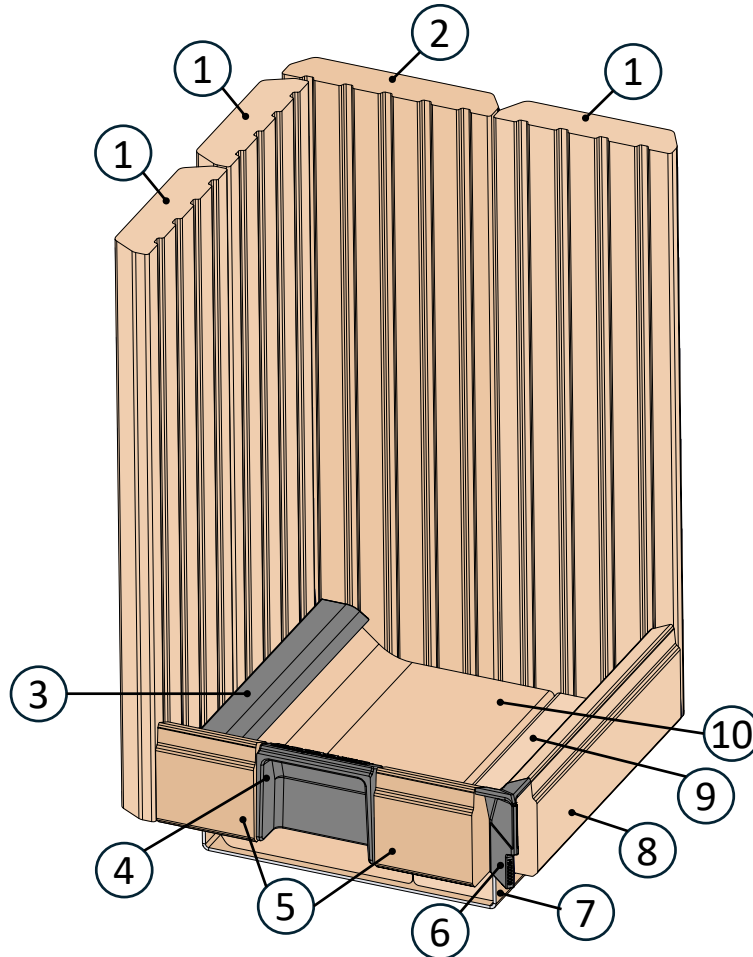

Position	Designation	Art. No.	Pcs.
1	Stone 572x173x40	HK000011	3
2	Stone 572x203x40	HK000012	1
3	Cast air distributor corner	HK000008	2
4	Cast inlay front	HK000007	1
5	Wedge stone 95x99x40	HK000156	2
6	Cast inlay corner	HK000009	1
7	Bottom insulation corner		1
8	Wedge stone 309x99x40	HK000054	1
9	Bottom stone corner 307x80x40	HK000157	1
10	Bottom stone corner 307x200x40	HK000015	1



Chamotte inner lining to be installed dry

4.6 VARIANTS HEAT EXCHANGER

4.6.1 CONNECTION WITH CATALYTIC CONVERTER

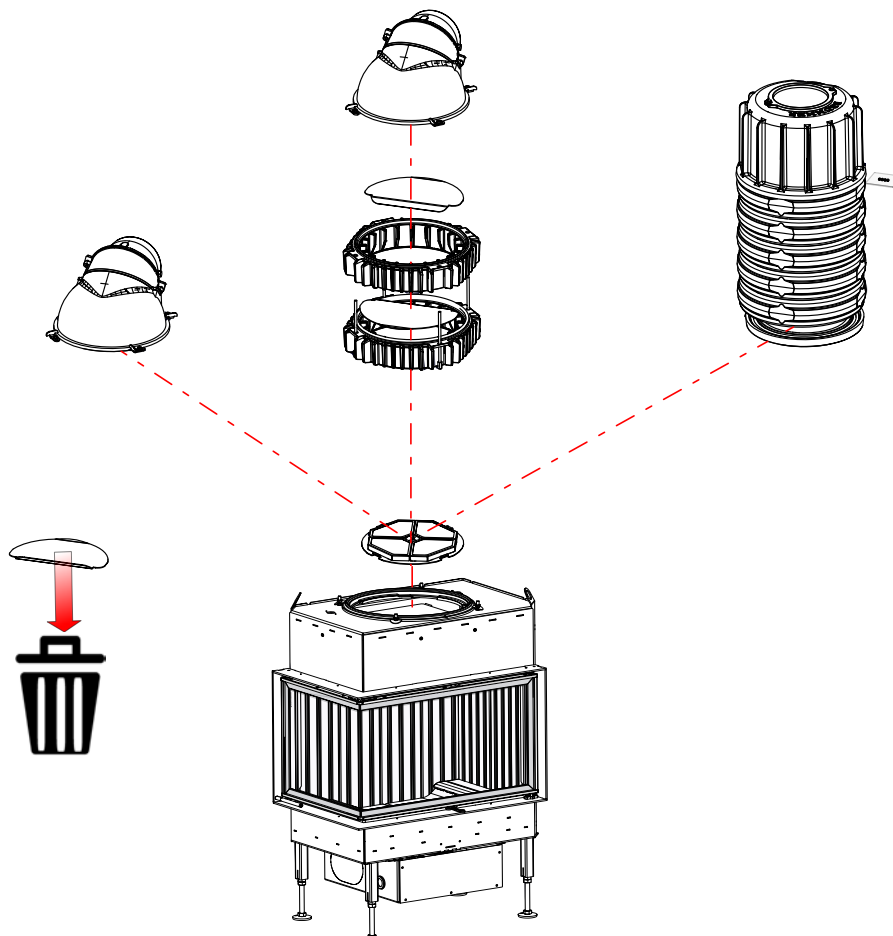

Mounting
catalytic
converter:
see

“ Fitting:
catalytic
converter”

4.6.2 CONNECTION WITHOUT CATALYTIC CONVERTER

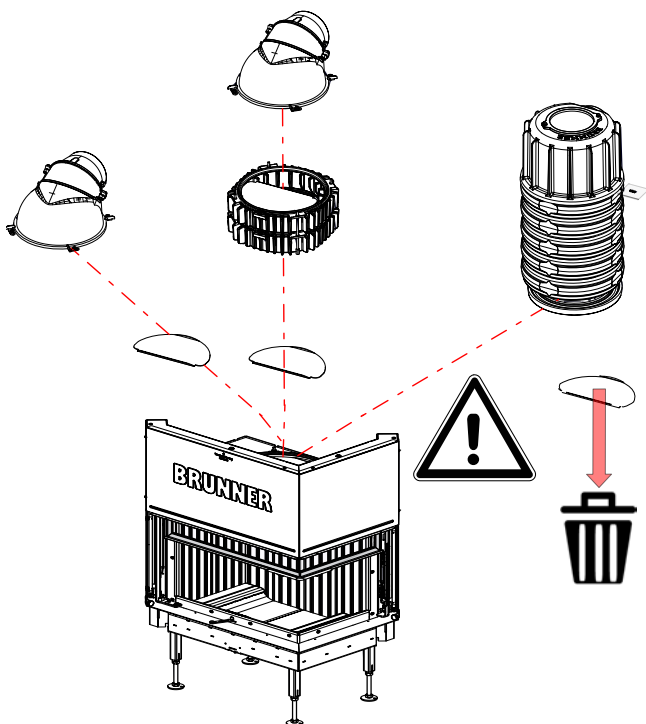

Possible variants of the connection for the outlet of flue gases

Position:
cast iron dome -
deflector plate

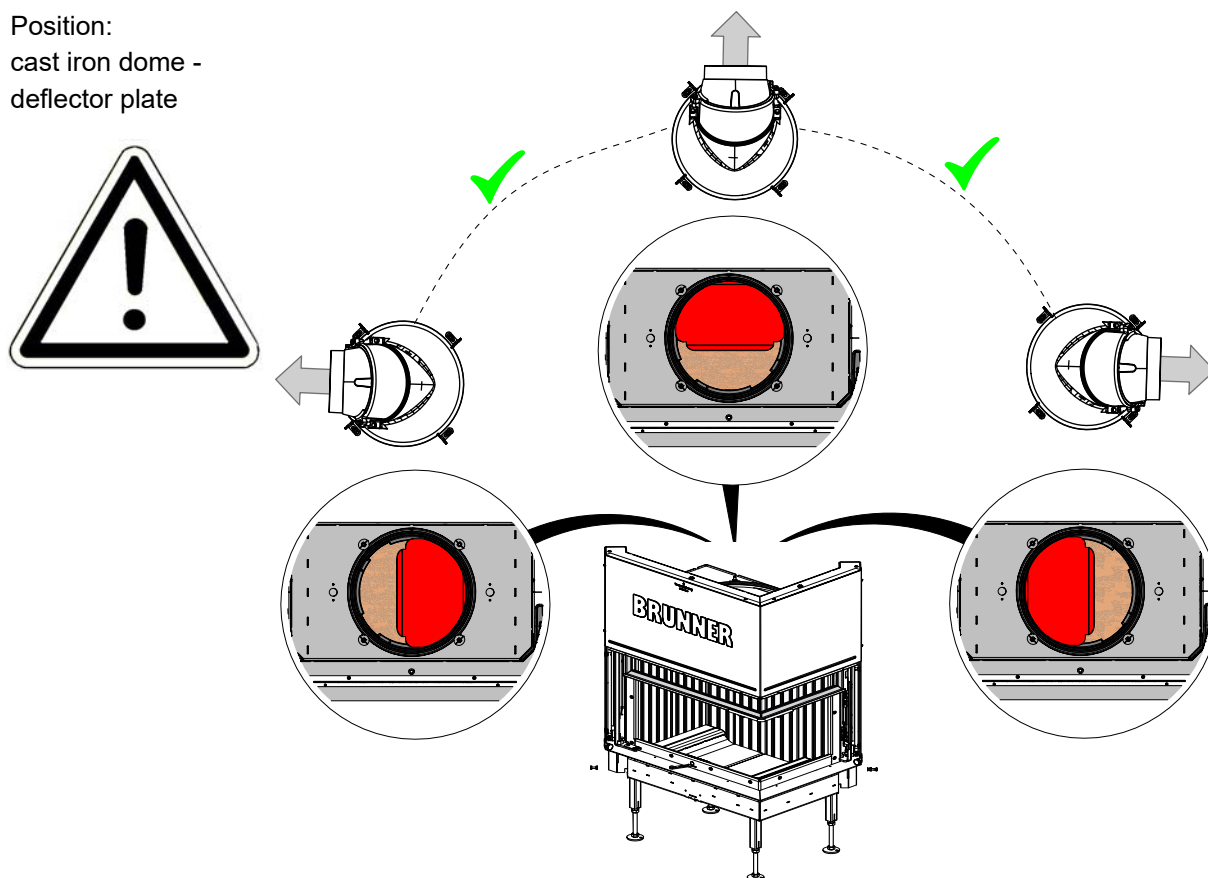

Examples for the position of the deflector plate : Connection variant for exhaust gases:

1) Example A: with rotating cast iron dome - at rear - vertical

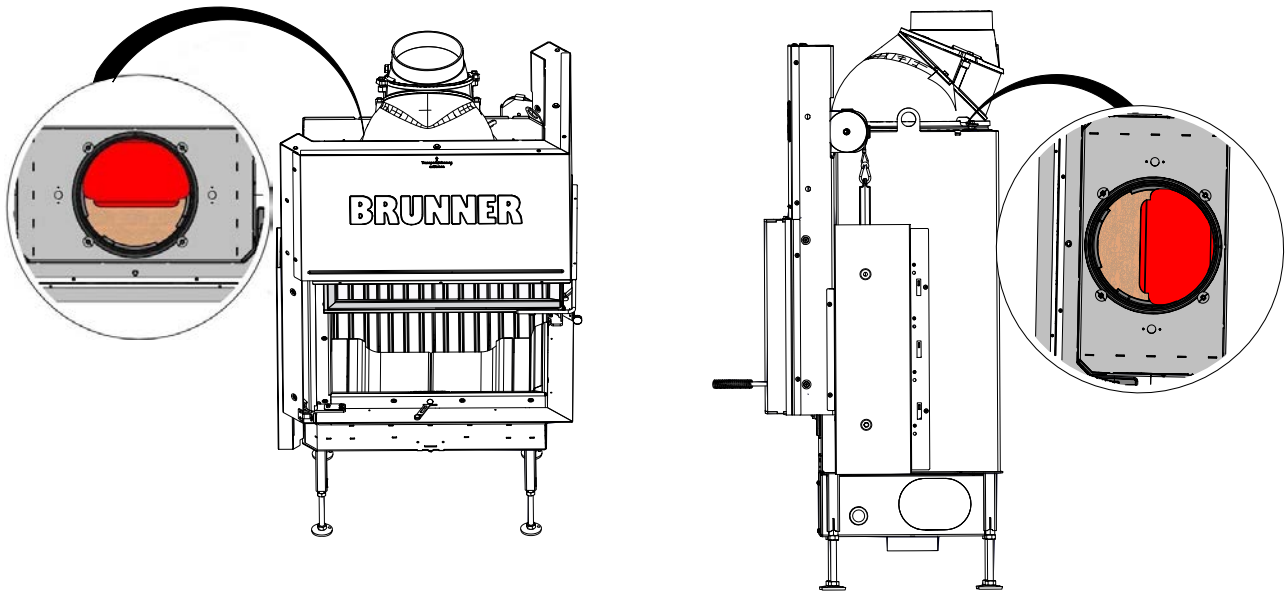

2) Example B: with rotating cast iron dome - at rear - horizontal

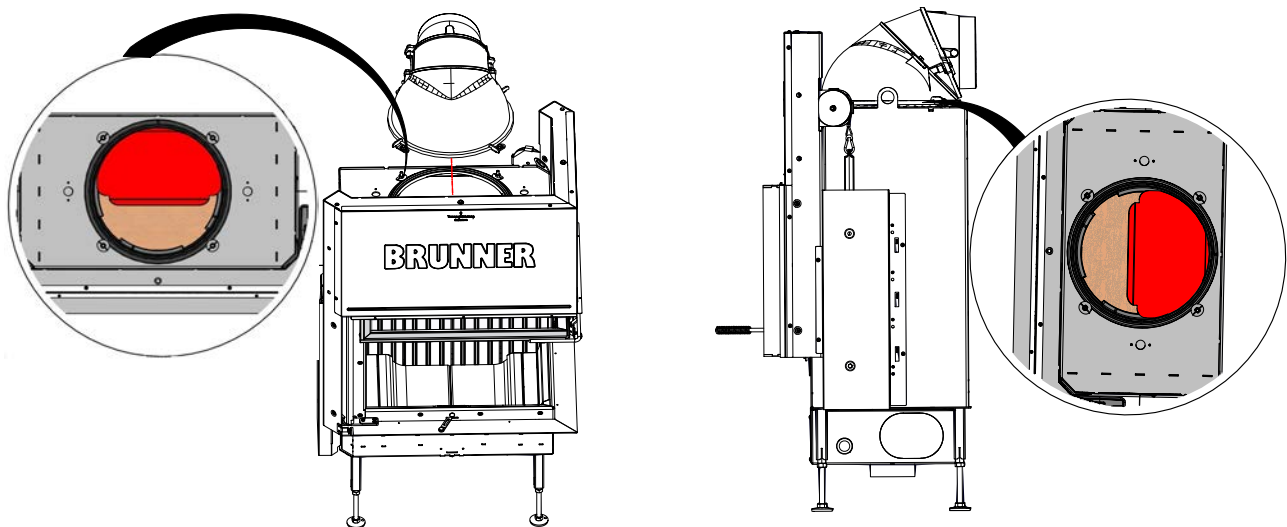

3) Example C: with rotating cast iron dome - left side - vertical or horizontal

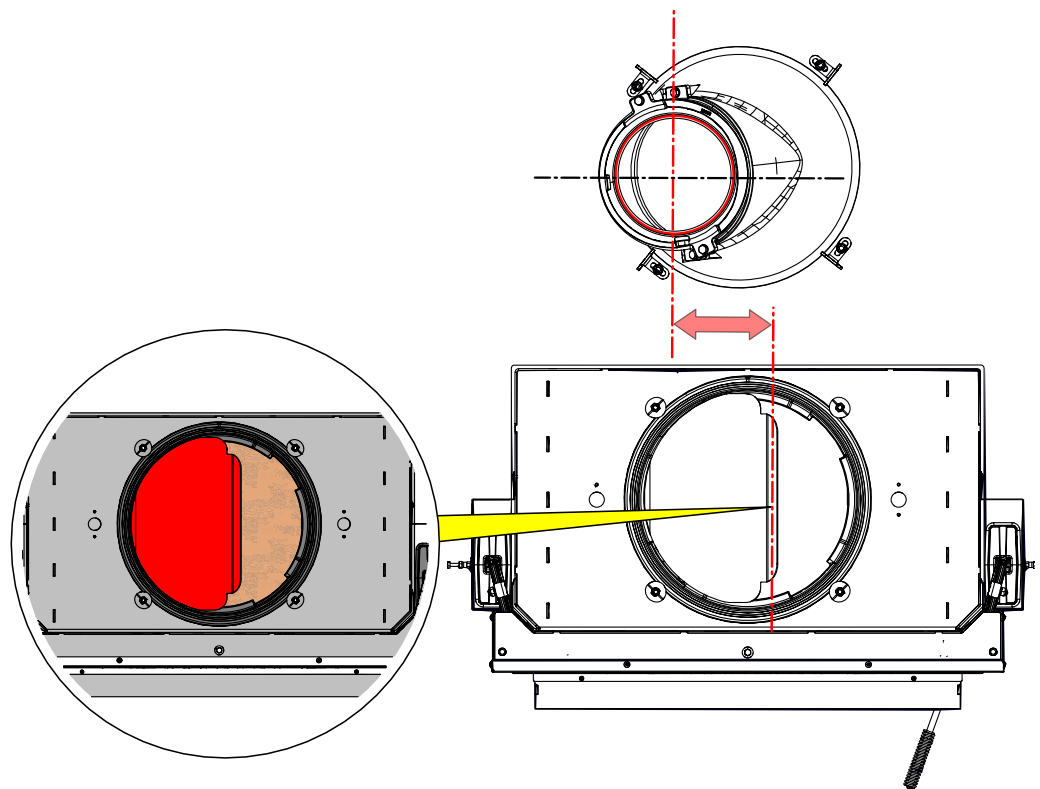
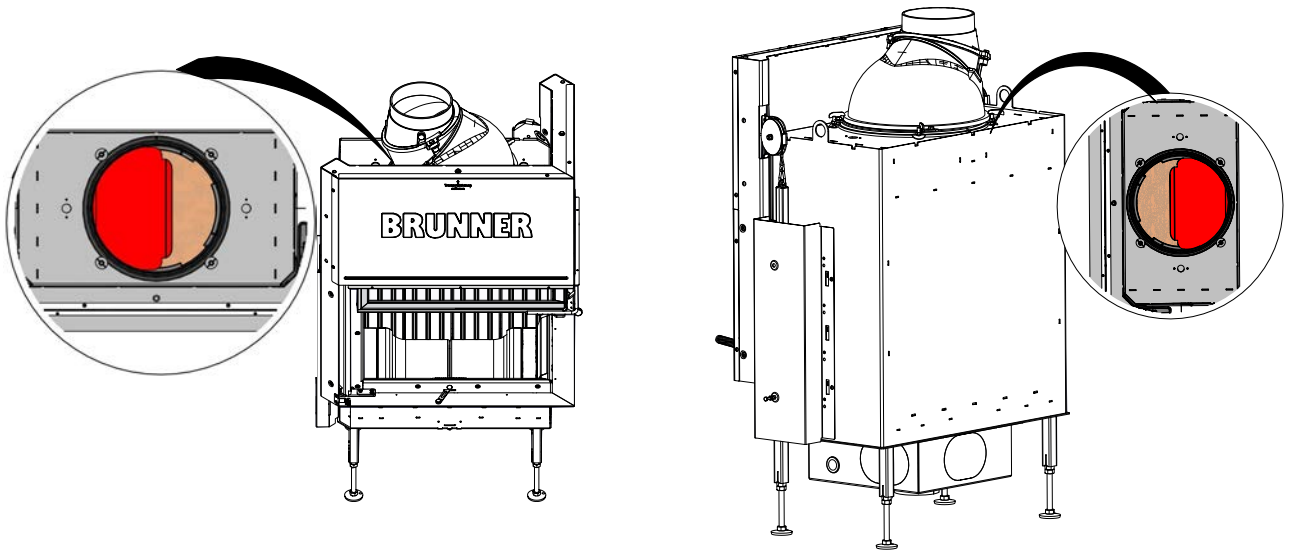

4) Example D: with rotating cast iron dome with heat exchanger ring - at rear - vertical or horizontal

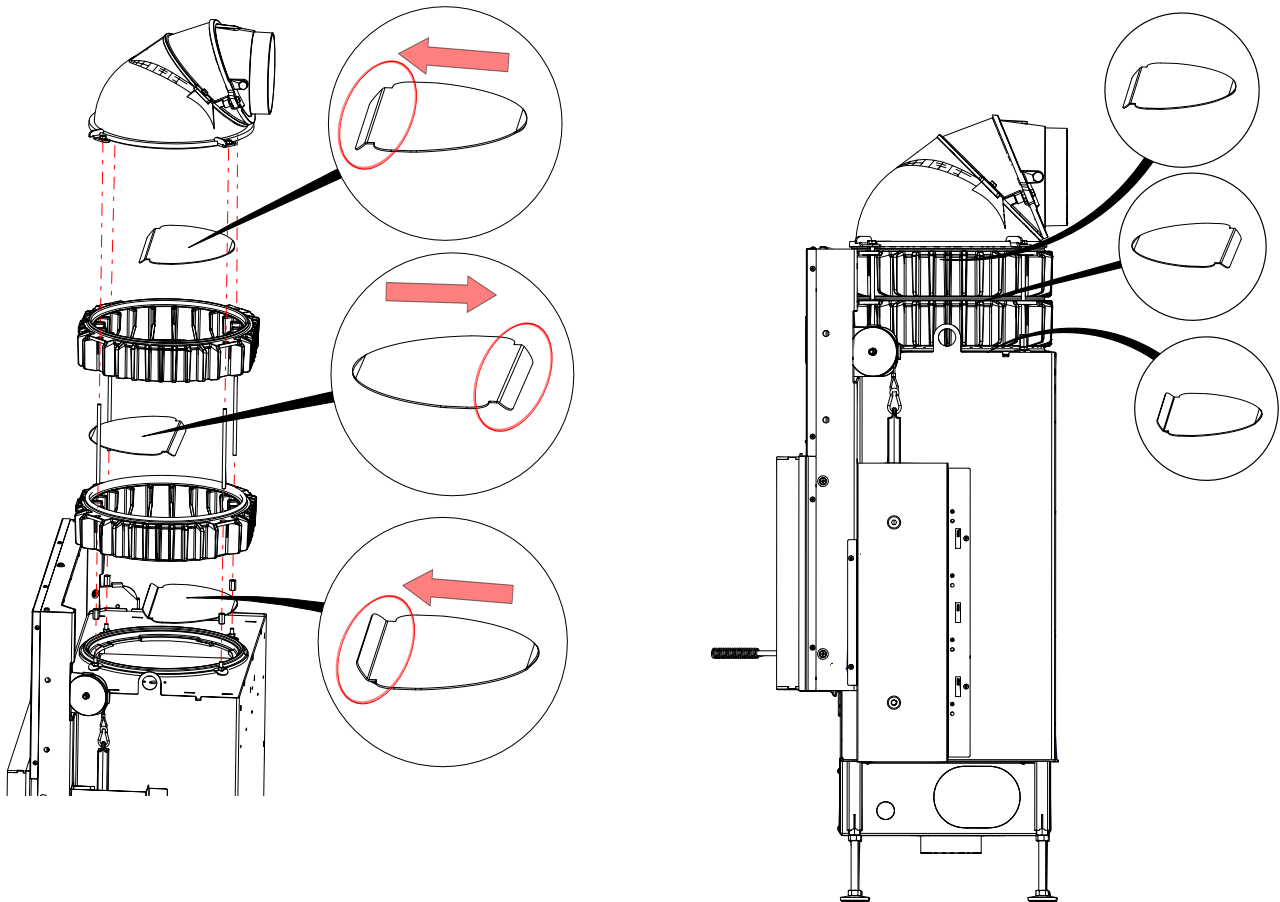

Principle of flue gas routing with heat exchanger rings

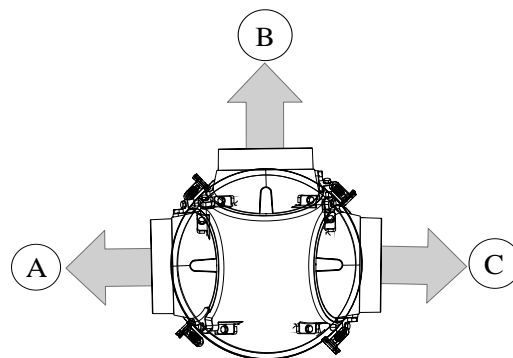

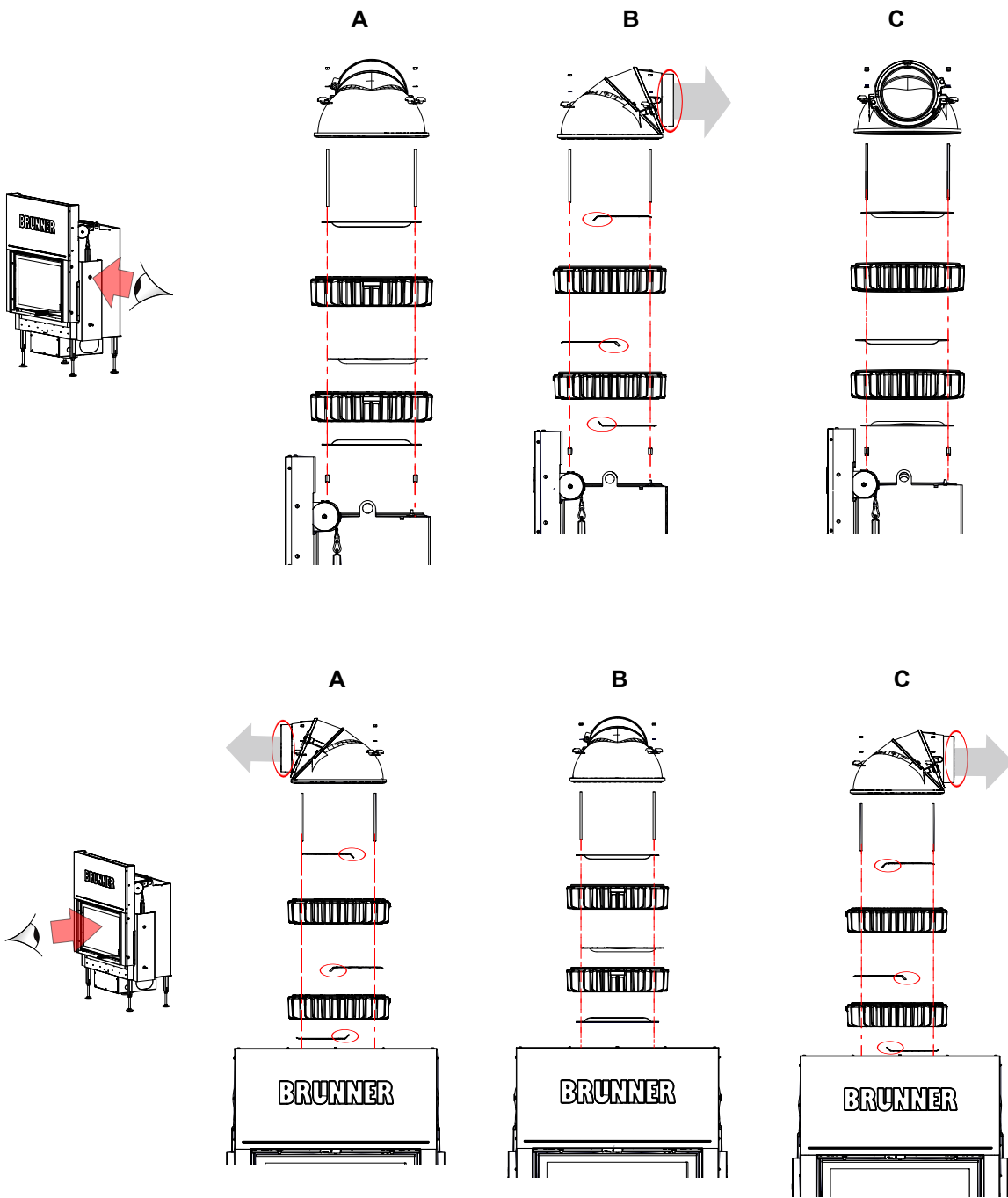

5) Example F: with rotating cast iron dome with cast iron heat exchanger rings - to the left vertical or horizontal

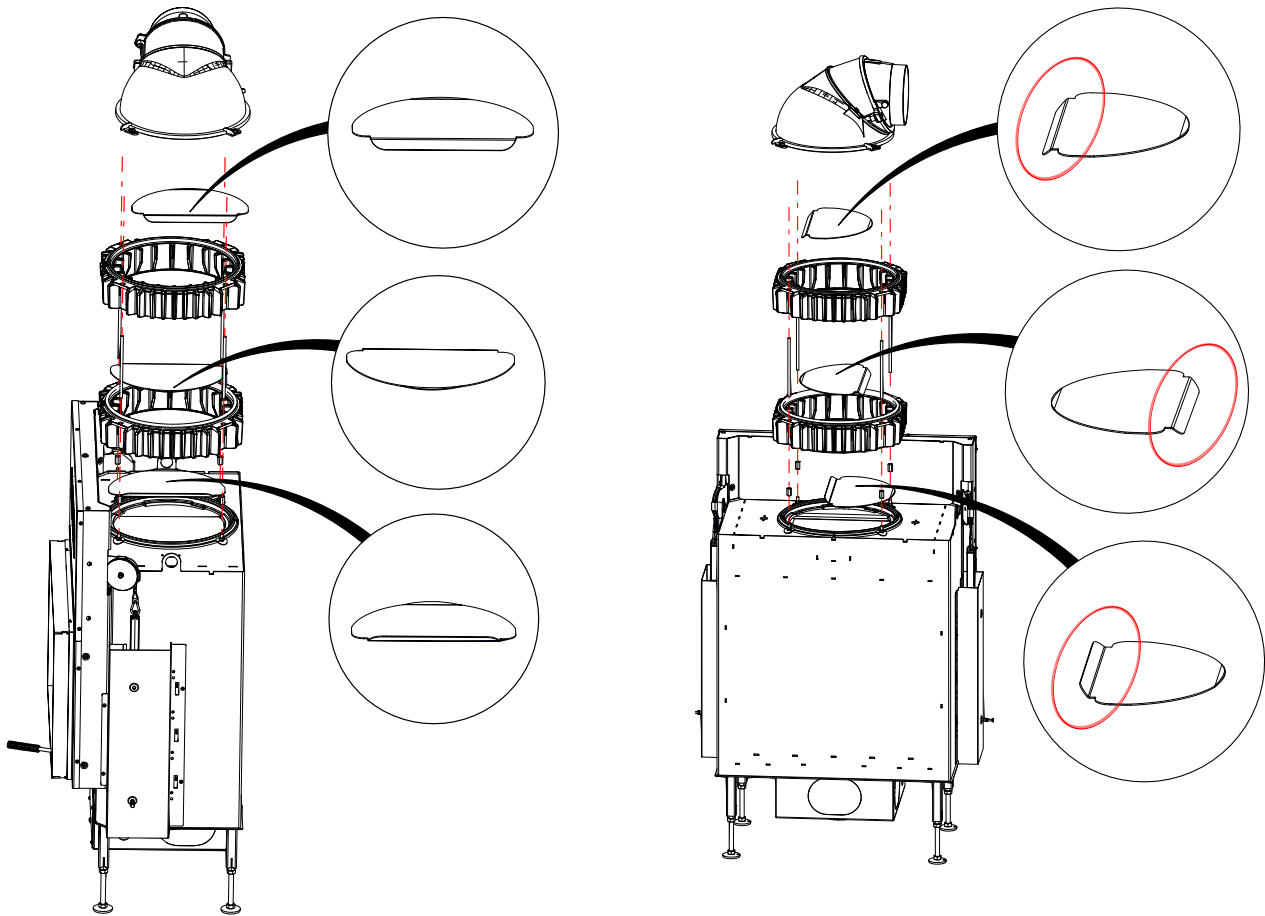

4.6.3 CAST IRON DOME

4.6.3.1 COMPONENTS CAST IRON DOME

Cast iron dome (\varnothing 180 mm = D004186 ; \varnothing 200 mm = 10087)

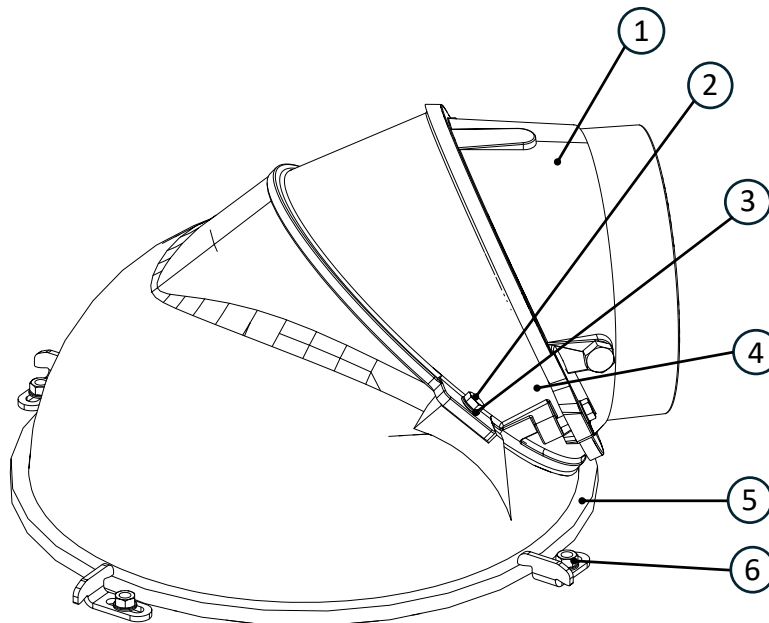

Position	Designation	Variant	Art.-Nr.	pcs
1	Connection bend	\varnothing 180 mm	D004188	1
		\varnothing 200 mm	10088	1
2	Hexagon head screw M8x25		00683	4
3	Washer		800267	4
4	Aufsatzbogen		08201	1
5	Dome		08200	1
6	Accessory pack		N008057	1

4.6.3.2 CAST IRON DOME

vertical outlet

horizontal outlet

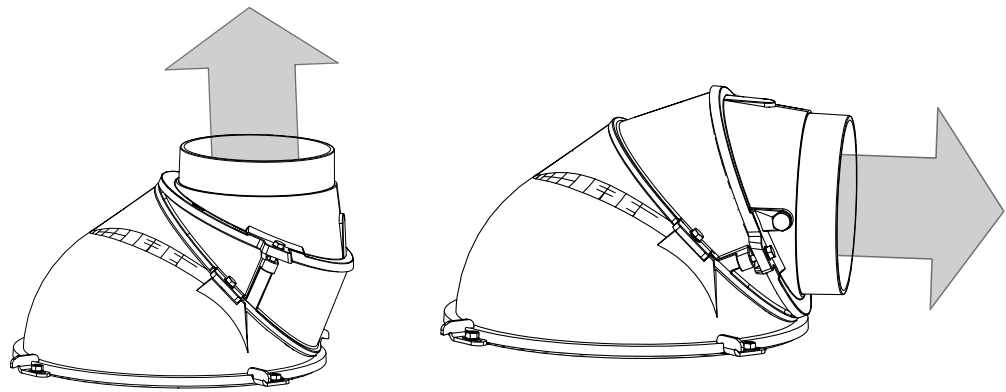

INFO modification: see enclosed sheet - cast iron dome

Summarised information:

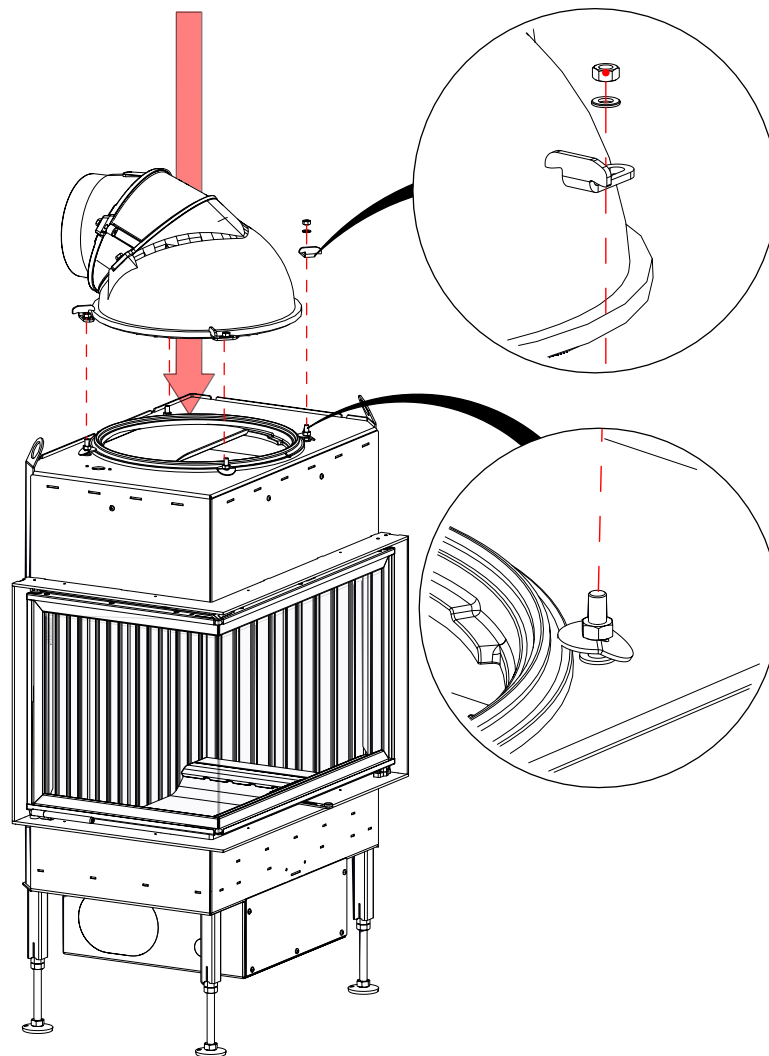

Workflow:

1

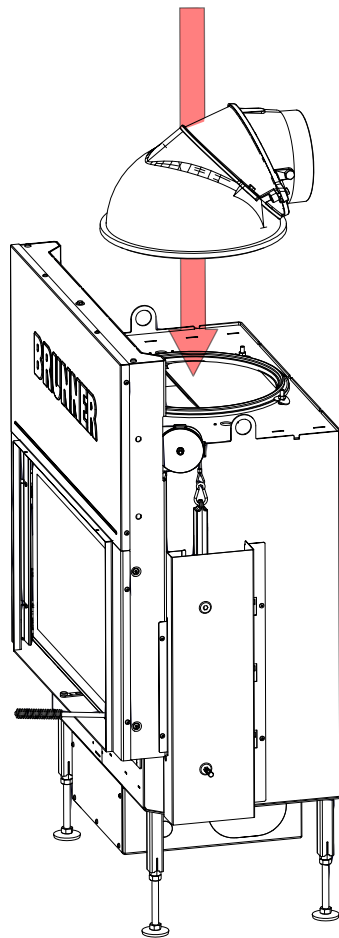

2

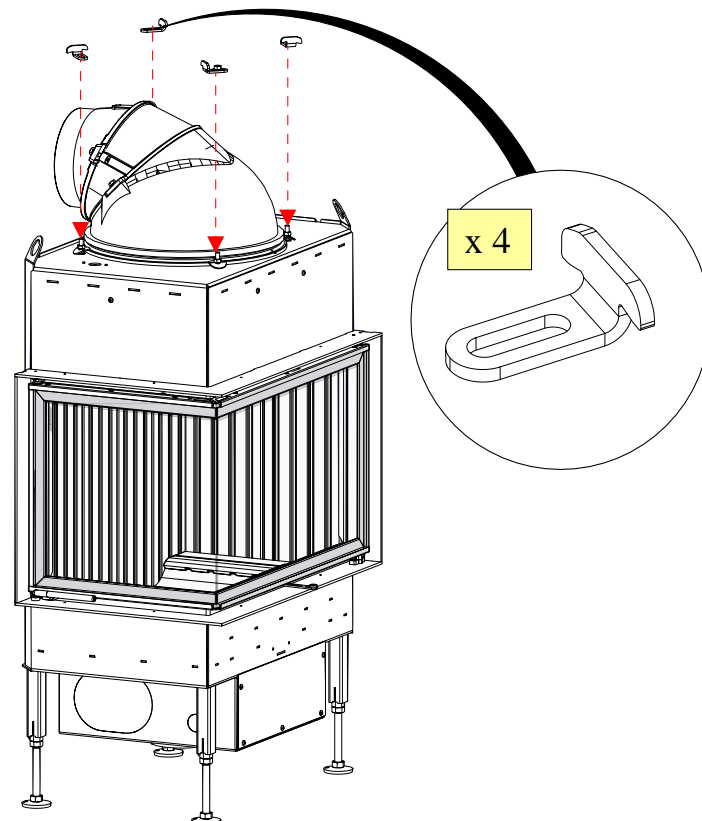

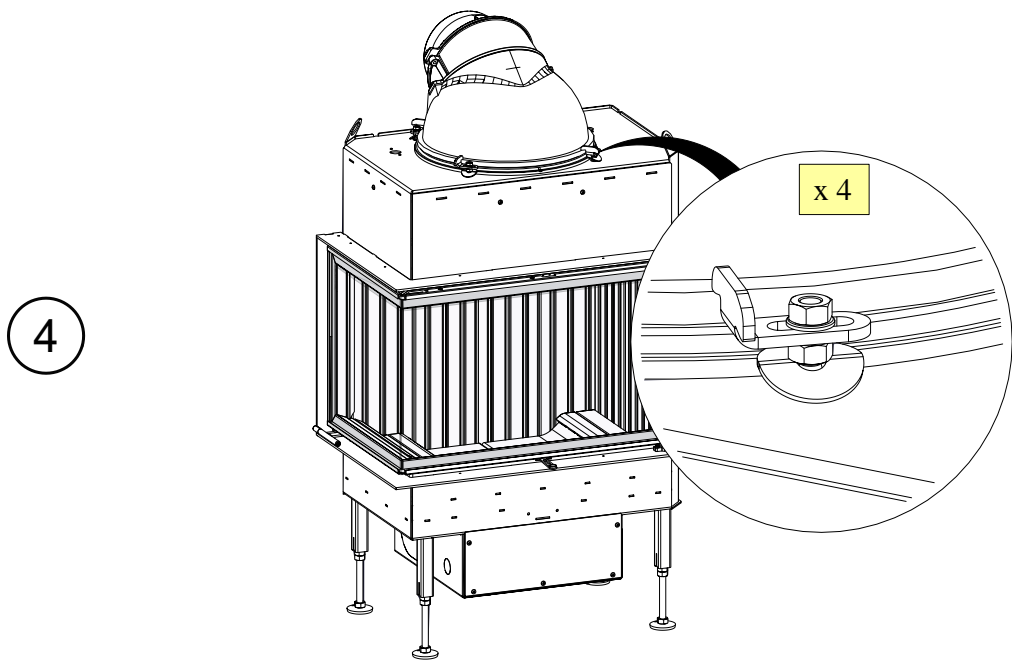
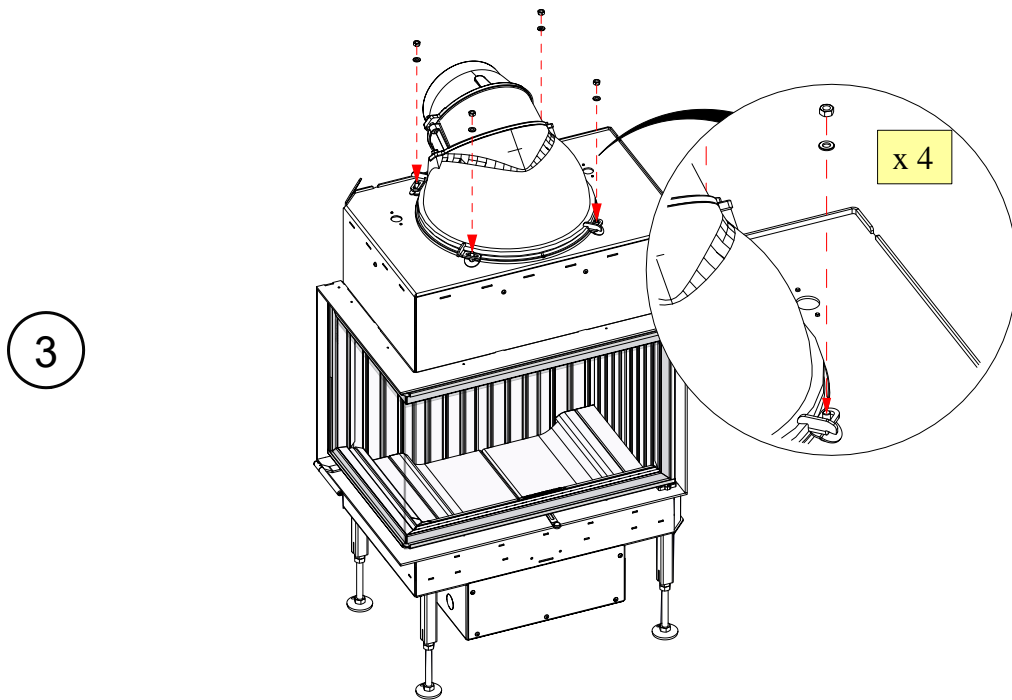

4.6.3.3 ADDITIONAL OPTION : HEAT EXCHANGER RINGS

4.6.3.3.1 COMPONENTS HEAT EXCHANGER RINGS

SET Heat exchanger rings (R015006-04)

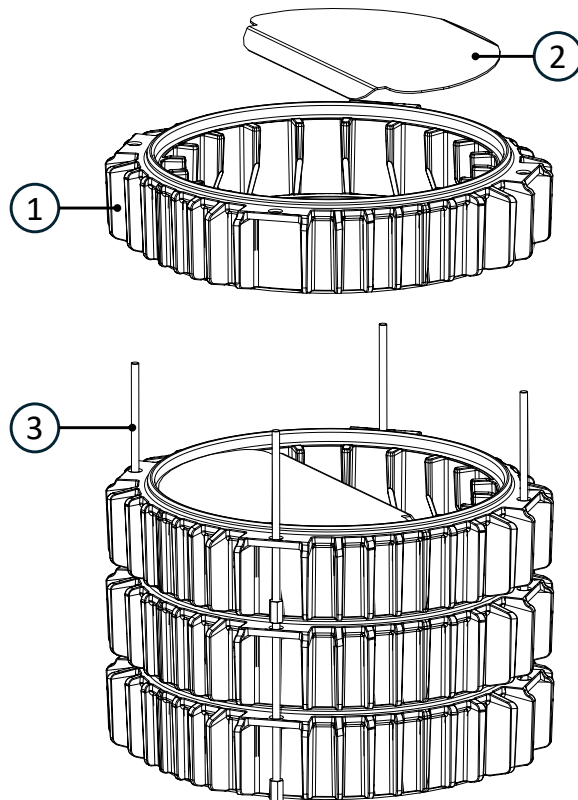

Position	Designation	Art.-Nr.	Pcs.
1	Cast iron heat exchanger ring	R015002	4
2	Heat exchanger deflector	R015003	4
3	Threaded rod M8x200	R015008	2

4.6.3.3.2 HEAT EXCHANGER RINGS

Summarised information:

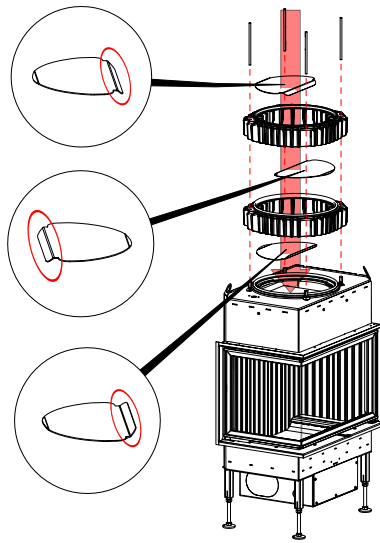

Workflow:

1

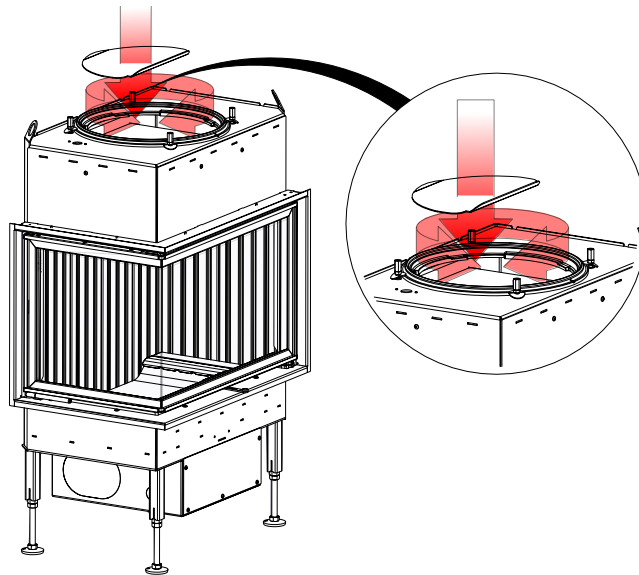

2

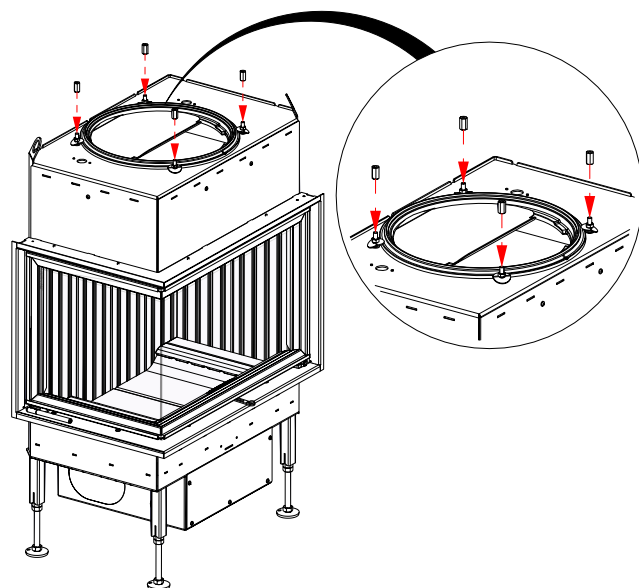

3

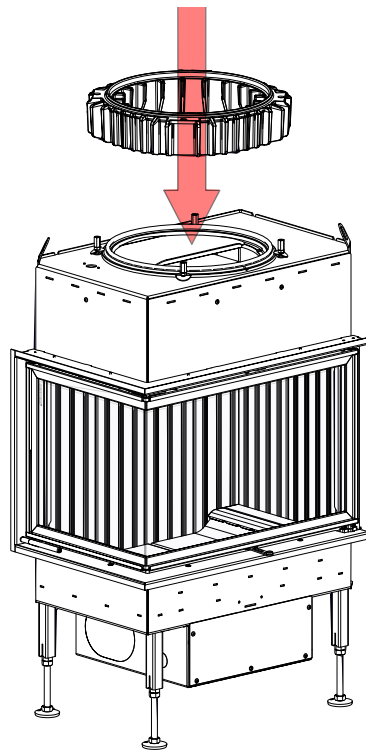

4

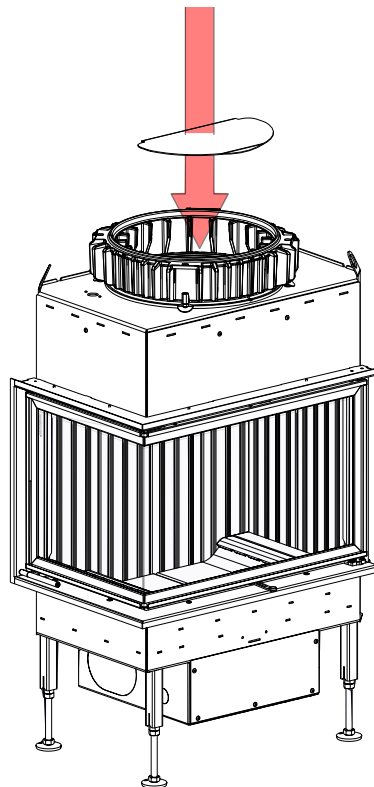

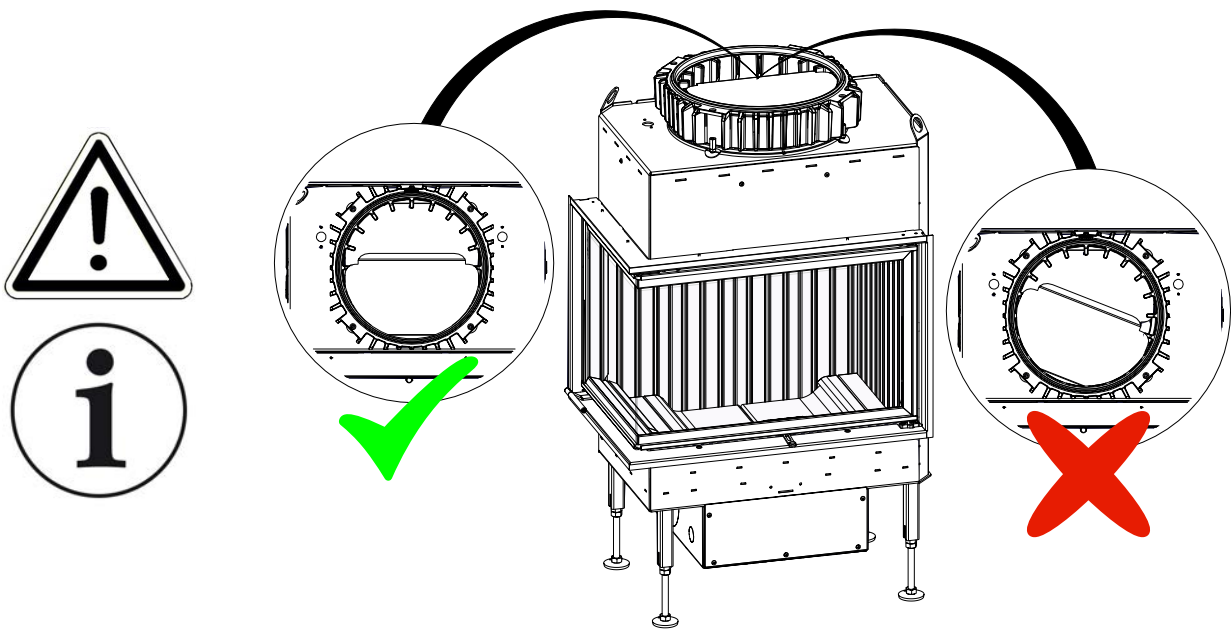

5

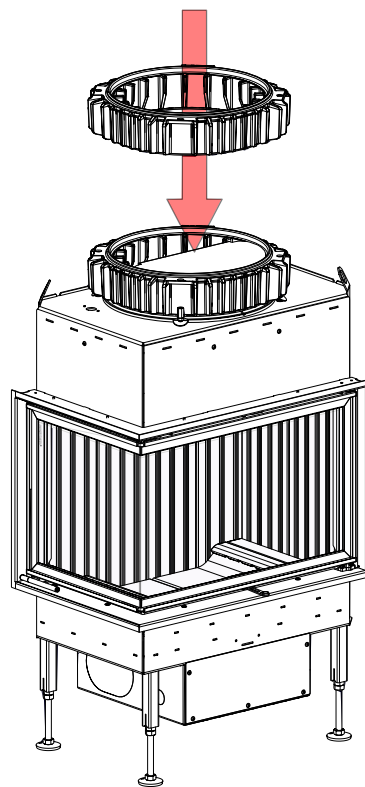

6

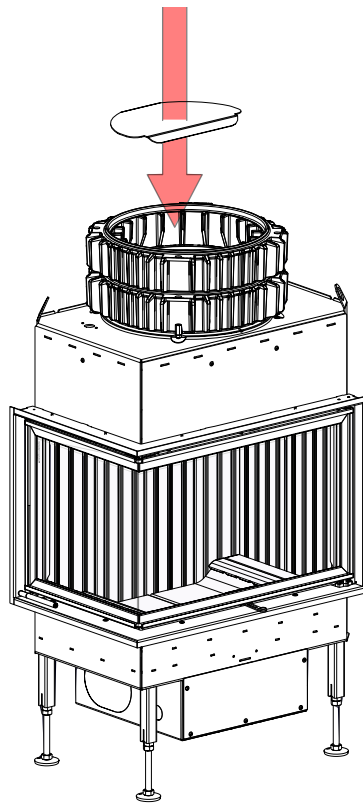

7

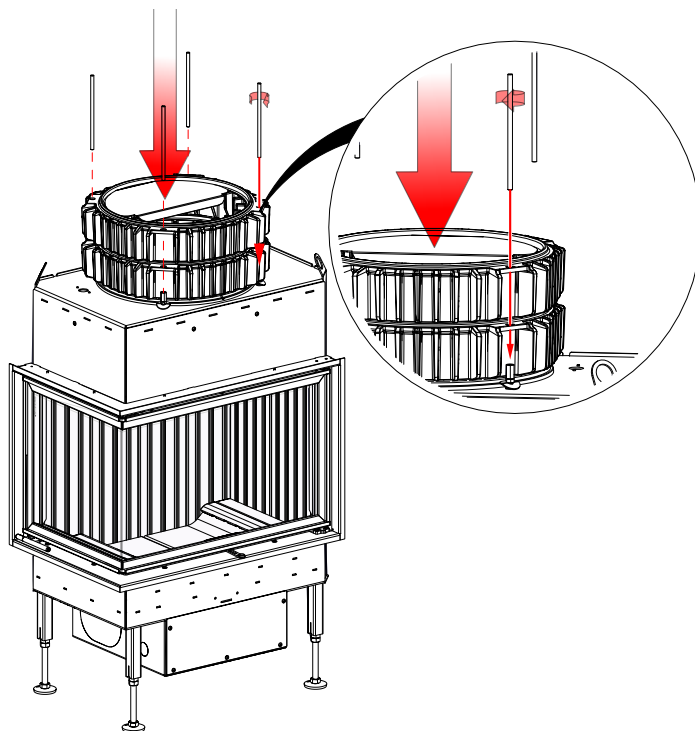

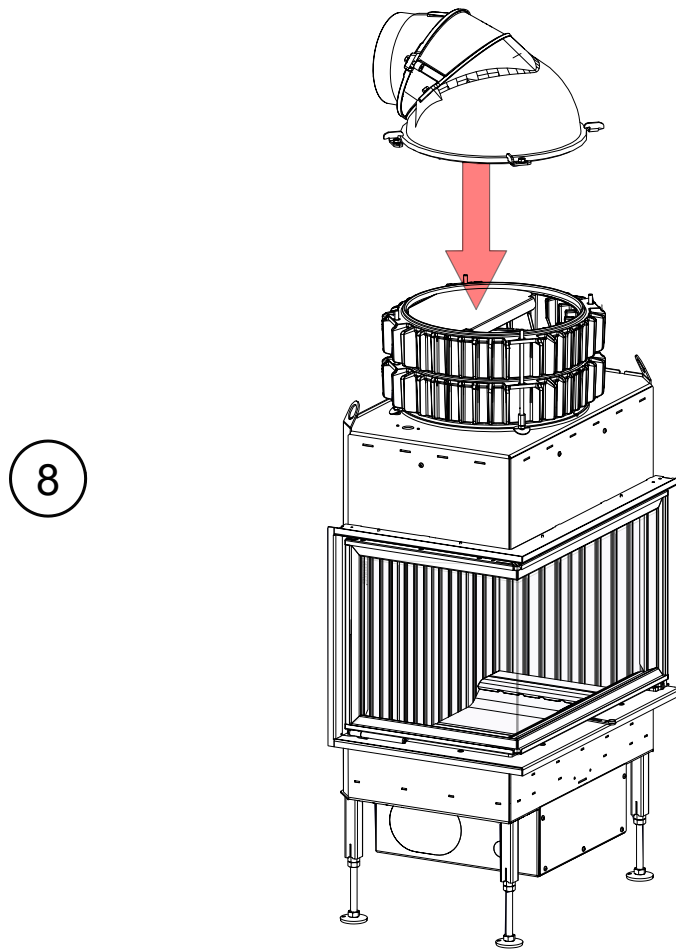

Thereafter: see "Cast iron dome"

4.6.4 MAS

4.6.4.1 COMPONENTS MAS MODULAR TOP-MOUNT STORAGE SET 440

MAS modular top-mount storage SET 440 (SET211444)

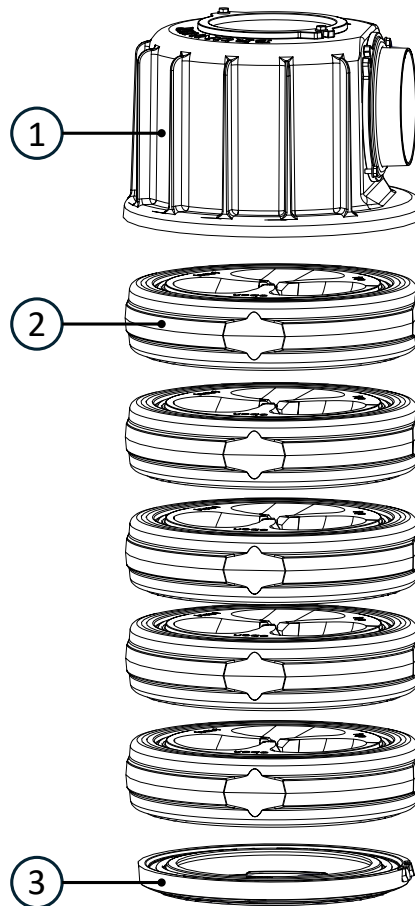

Position	Designation	Art.-Nr.	Pcs.
1	Cast iron dome ø 180 mm	R009095-01	1
2	MAS 440 accumulation stone double-layered	R009042	5
3	Mounting ring	10077	1

4.6.4.2 HEAT EXCHANGER MAS

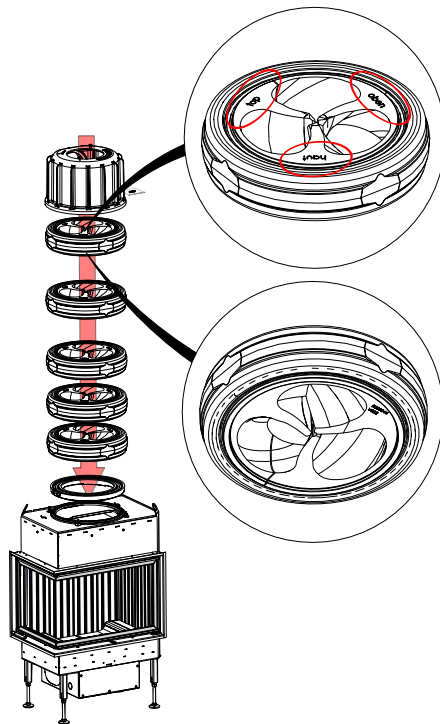

Im. 2: Summarised information

Workflow:

1

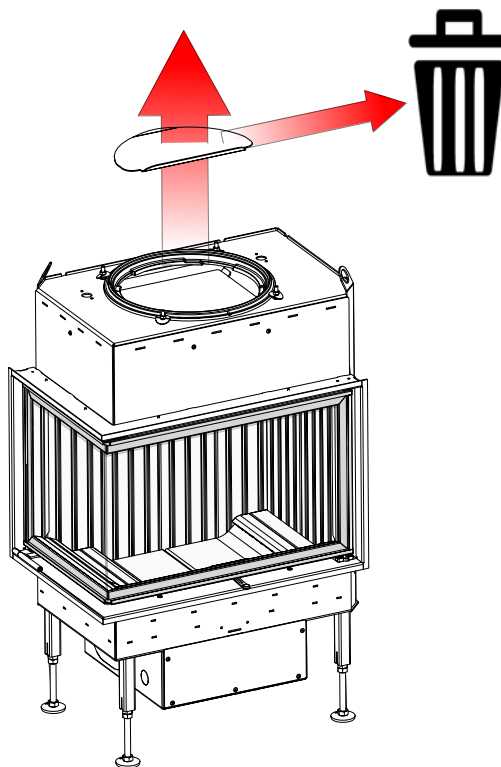

2

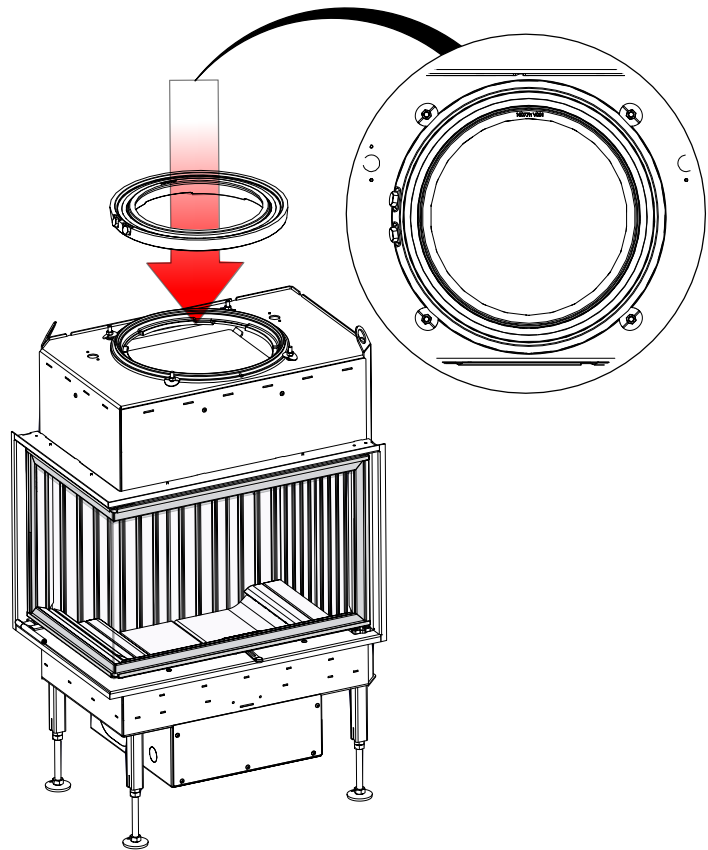

3

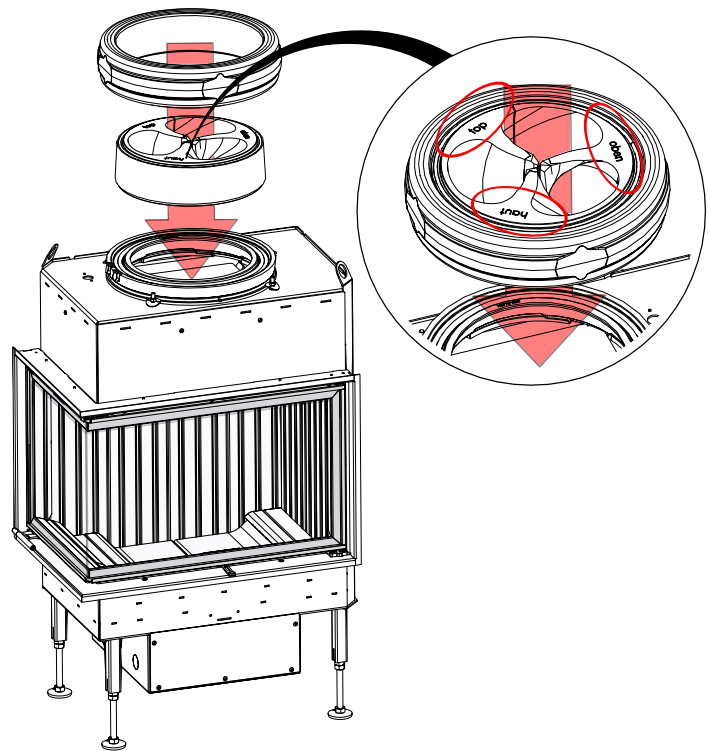

4

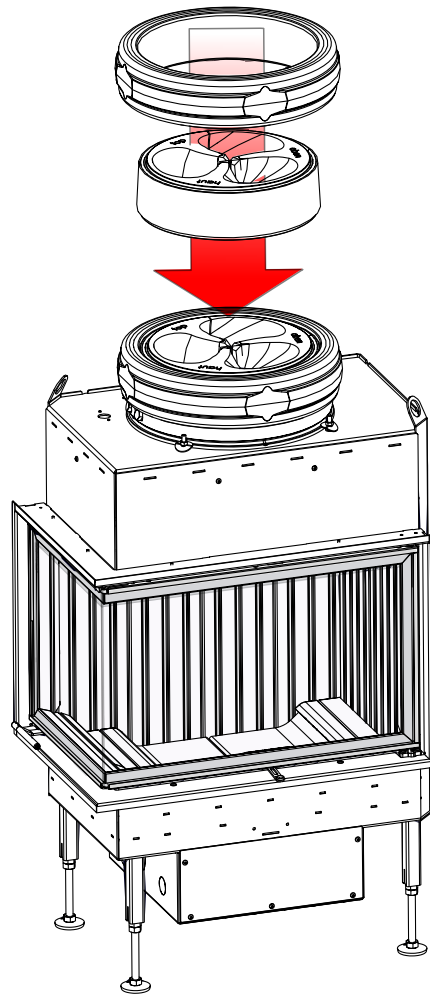

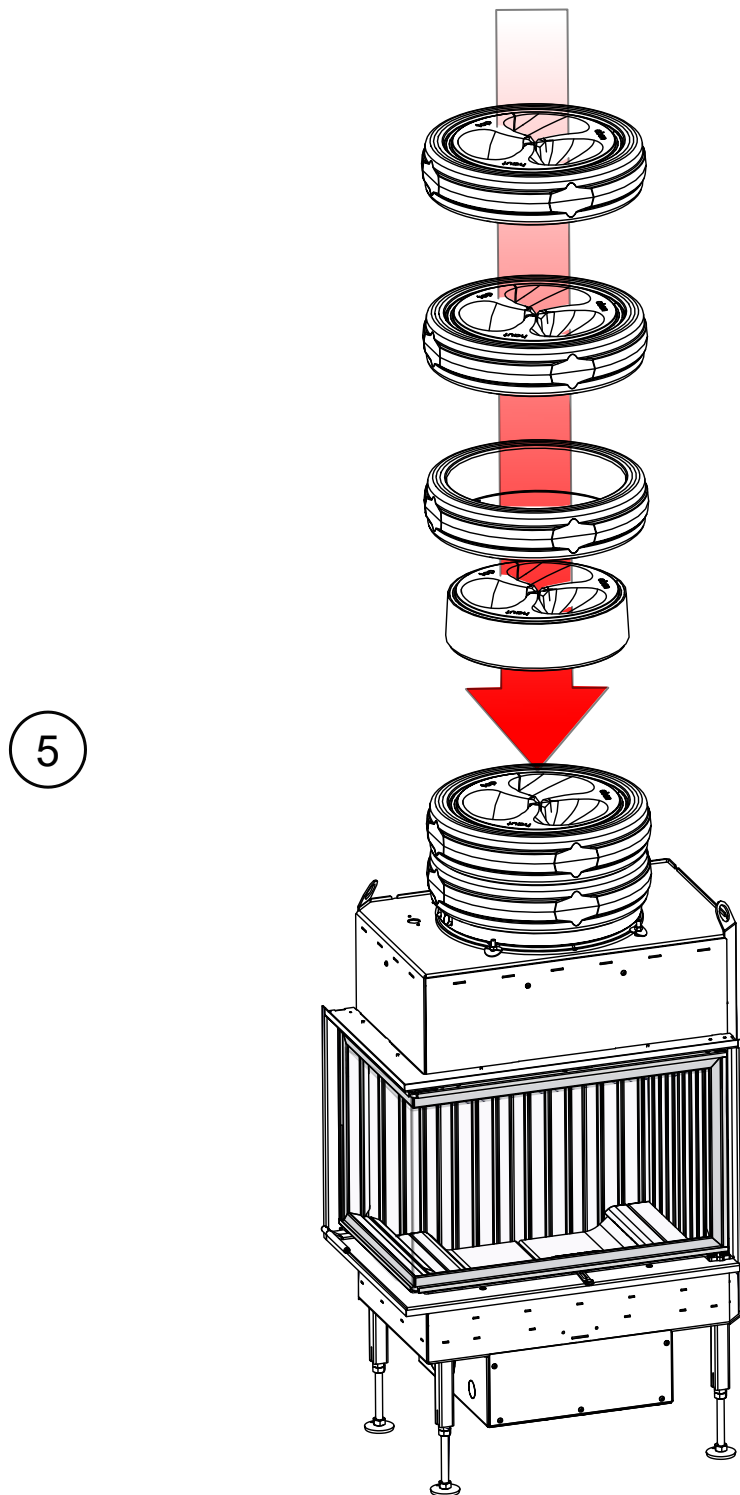

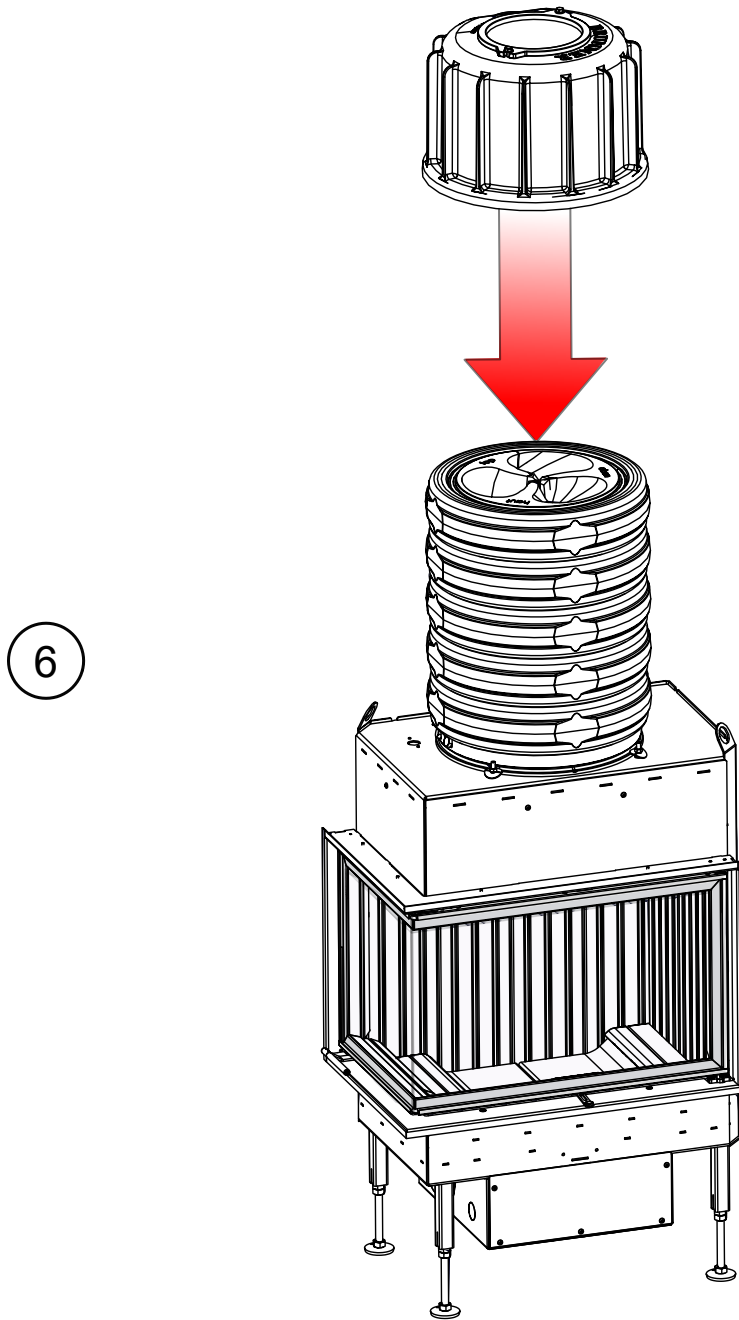

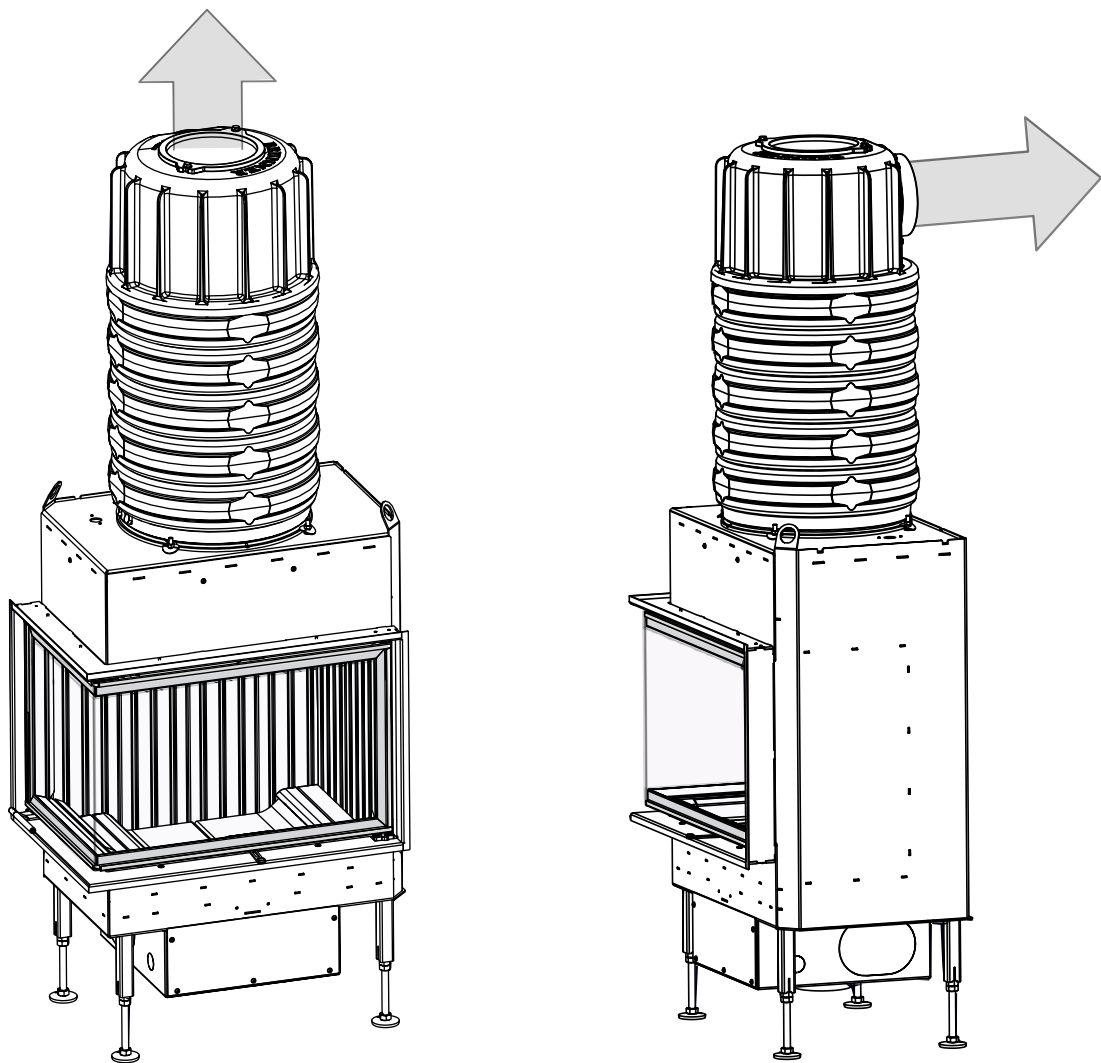

NOTICE

Ensure correct position after fitting the cast iron dome!

During installation, the cast dome can shift so that it no longer sits correctly aligned on the mounting ring.

- ▶ Check with light test: Illuminate the combustion chamber to make any gaps between the mounting ring and the cast iron dome visible.

4.7 VARIANT: EOS

4.7.1 BOTTOM COVER AIR BOX EOS

4.7.1.1 COMPONENTS EOS

BG Bottom cover Air box small, EOS (HK000064)

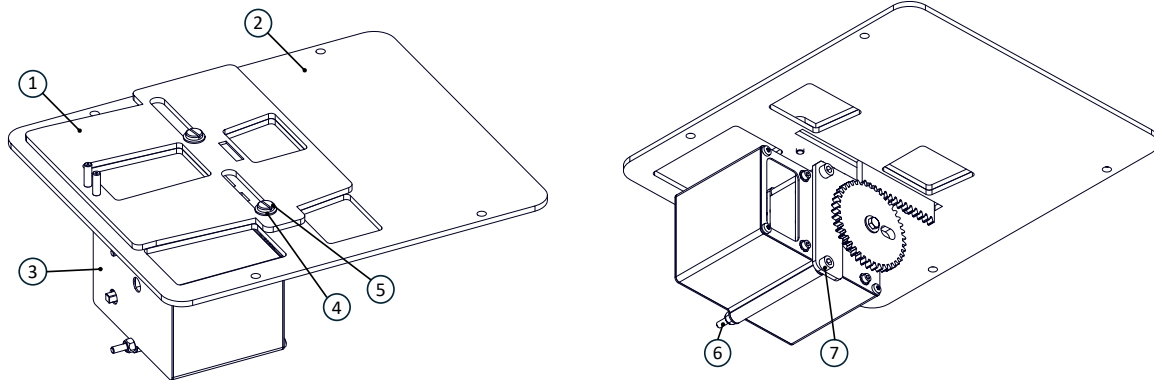

Position	Designation	Art.-Nr.	pcs
1	Air slide plate small EOS	HK000232	1
2	BG Bottom cover Air box small EOS	HK000219	1
3	BG Servomotor EOS with Gear wheel	N003157	1
4	Collar bushing	I007337	2
5	Flat head screw (M5x6)	800461	2
6	hexagon nut with Clamping part	800155	2
7	Cylinder head screw (M5x100)	800035	2

4.7.1.2 FITTING: EOS

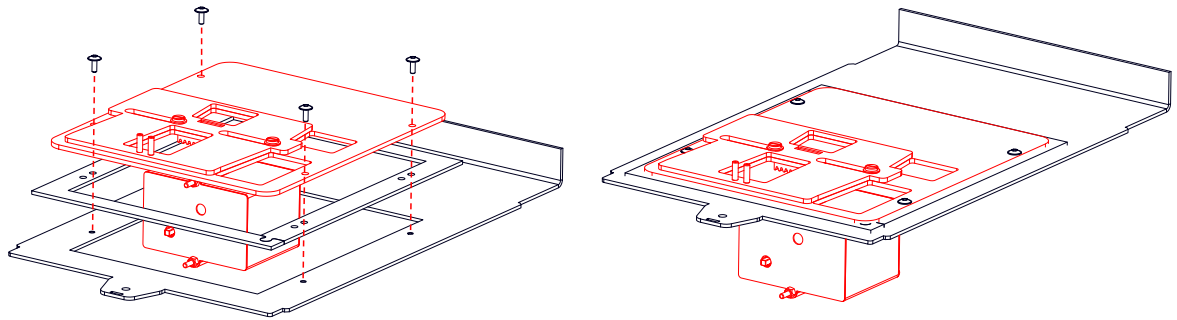

1

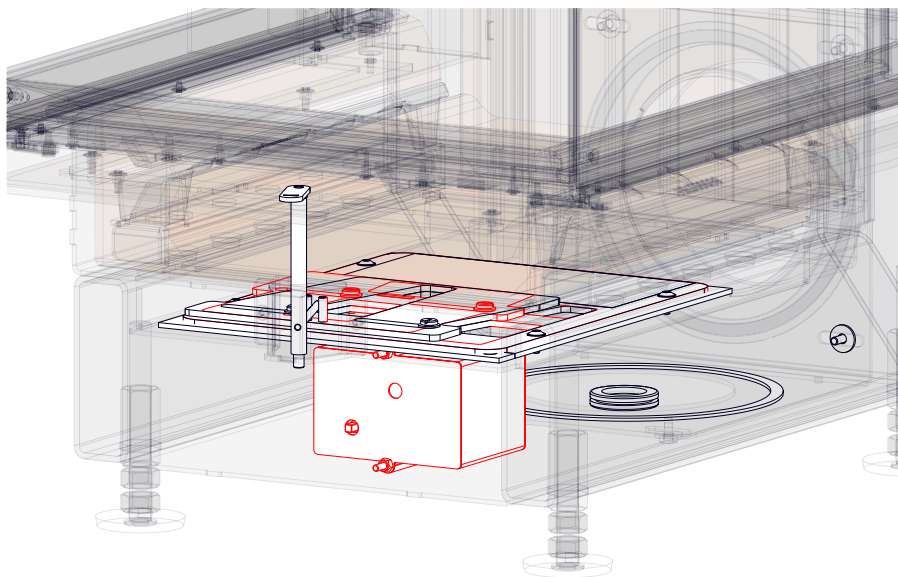
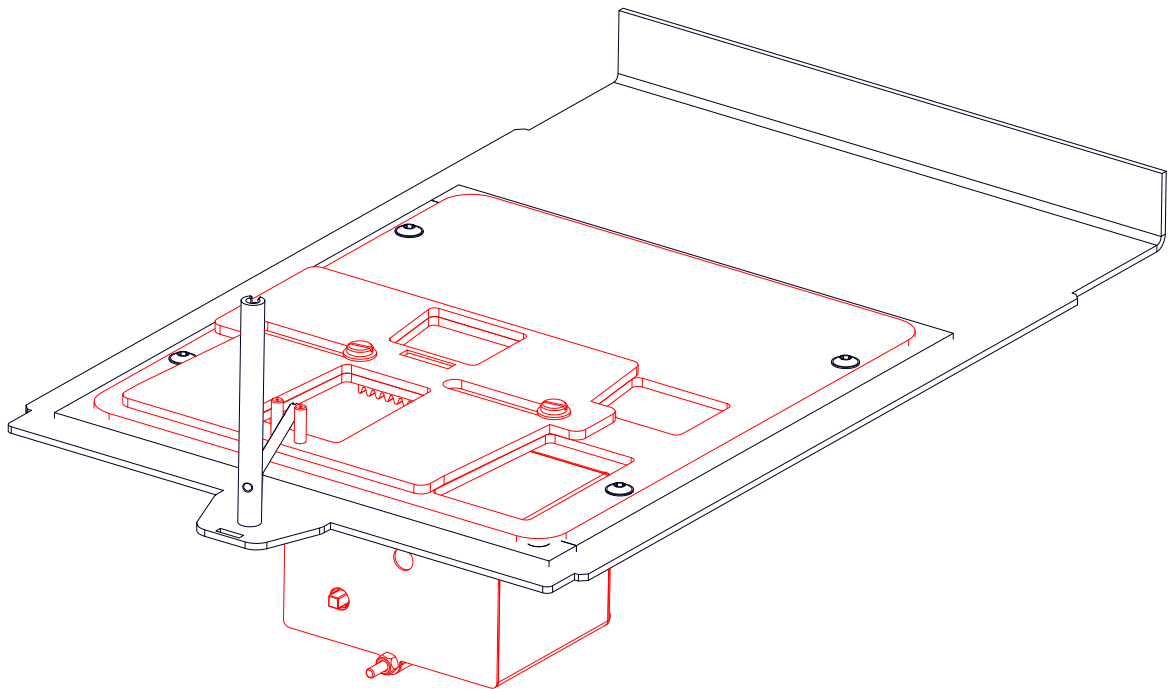

4.7.1.3 MEMBRANE FEED-THROUGH

Membrane feed-through (901248)

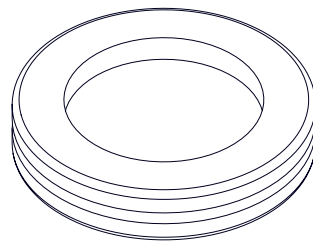

Position

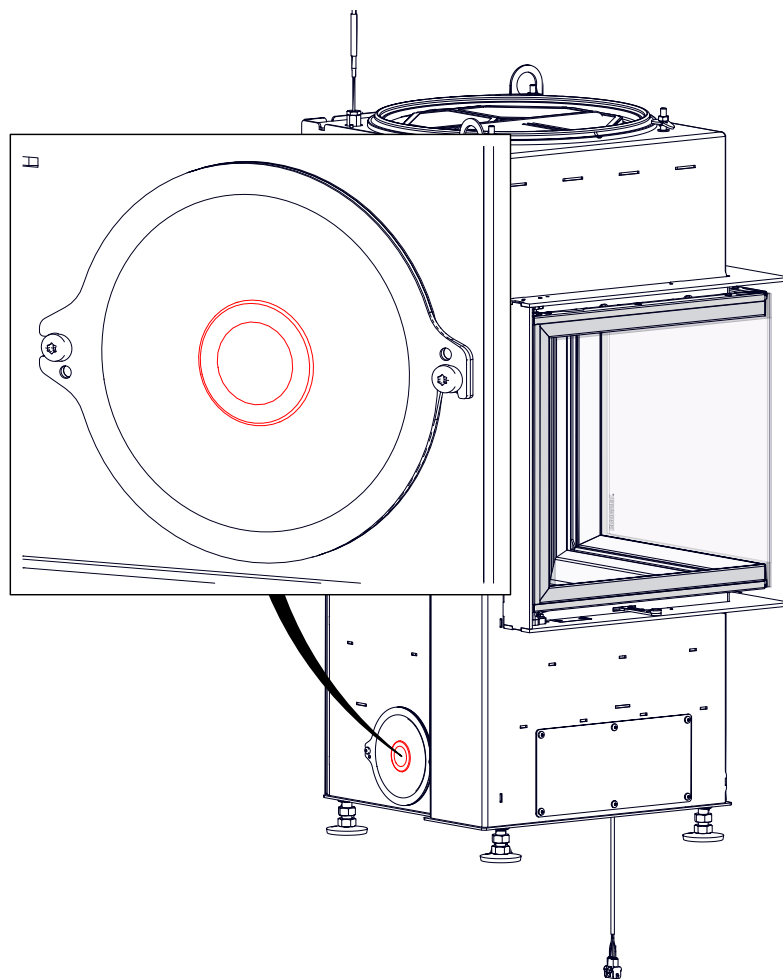

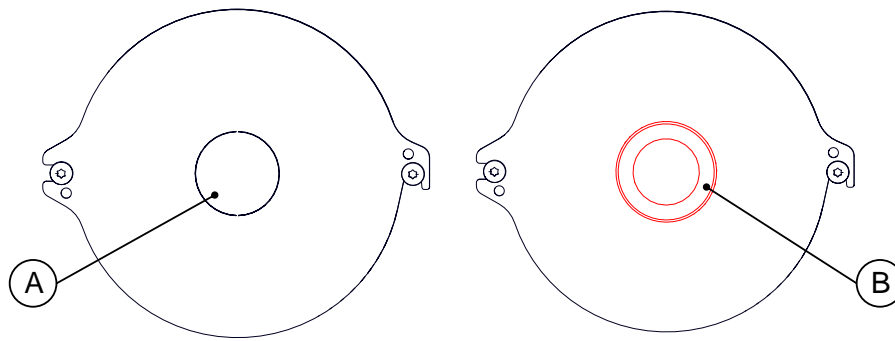

A = BKH

B = BKH with EOS

4.7.1.4 AIR POSITION INDICATOR

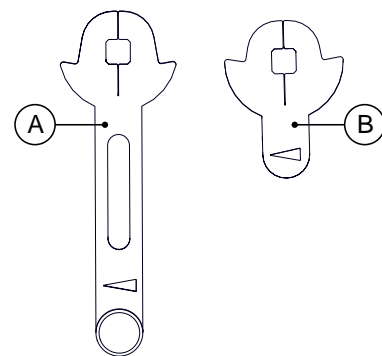
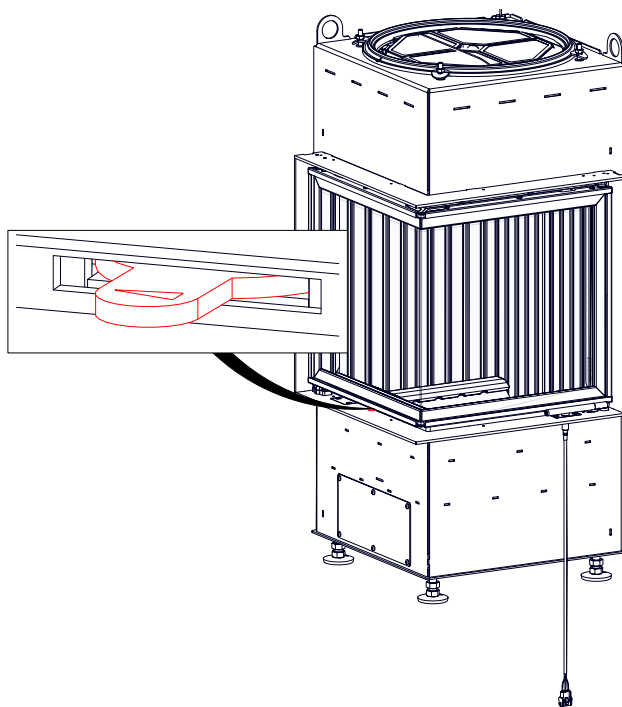

A = BKH

B = BKH with EOS

4.7.2 THERMOCOUPLE

4.7.2.1 COMPONENTS THERMOCOUPLE

BG Thermocouple with Retaining plate (HK000095)

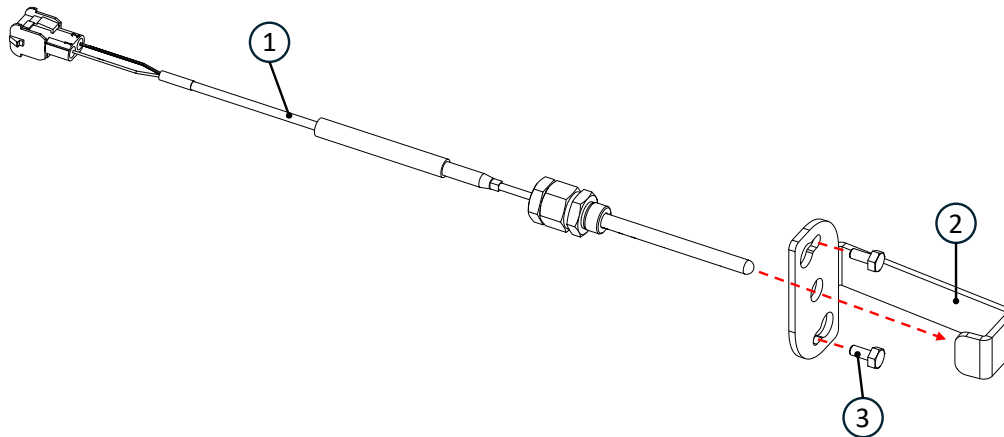

Position	Designation	Art.-Nr.	Pcs.
1	BG Thermocouple	10992.1	1
2	Thermocouple Retaining plate	HK000216	1
3	Hexagon head screw (M5x10)	02531	2

4.7.2.2 FITTING: THERMOCOUPLE

Position

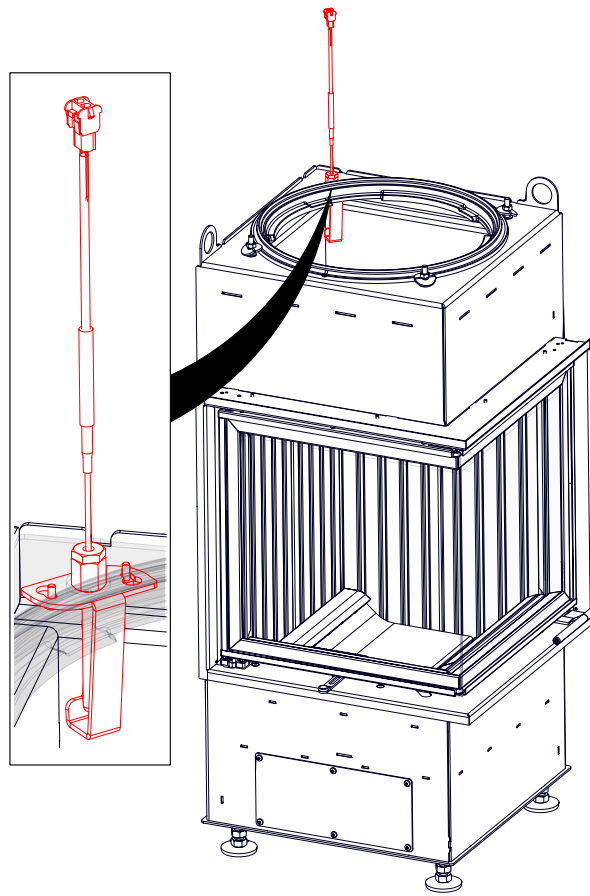

Workflow

1

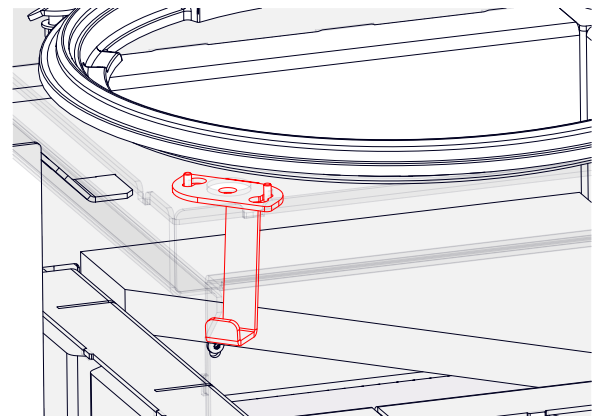
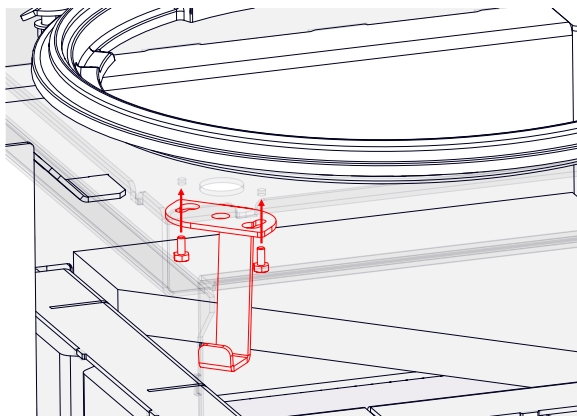

2

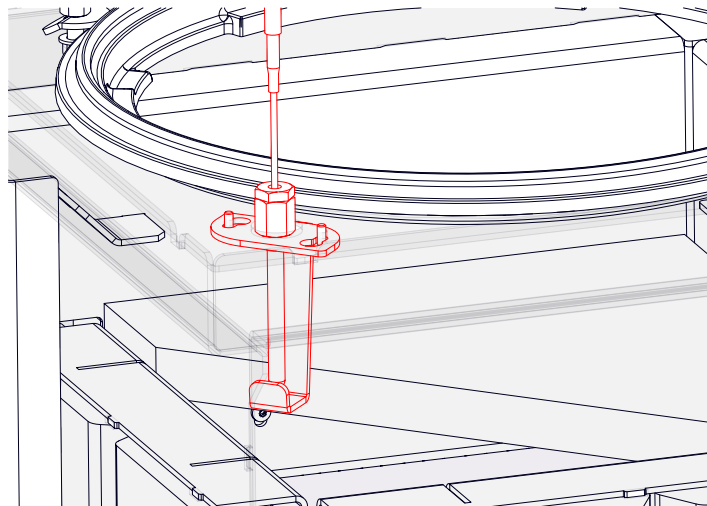

4.7.3 DOOR CONTACT SWITCH

4.7.3.1 COMPONENTS DOOR CONTACT SWITCH

Door contact switch (E011001)

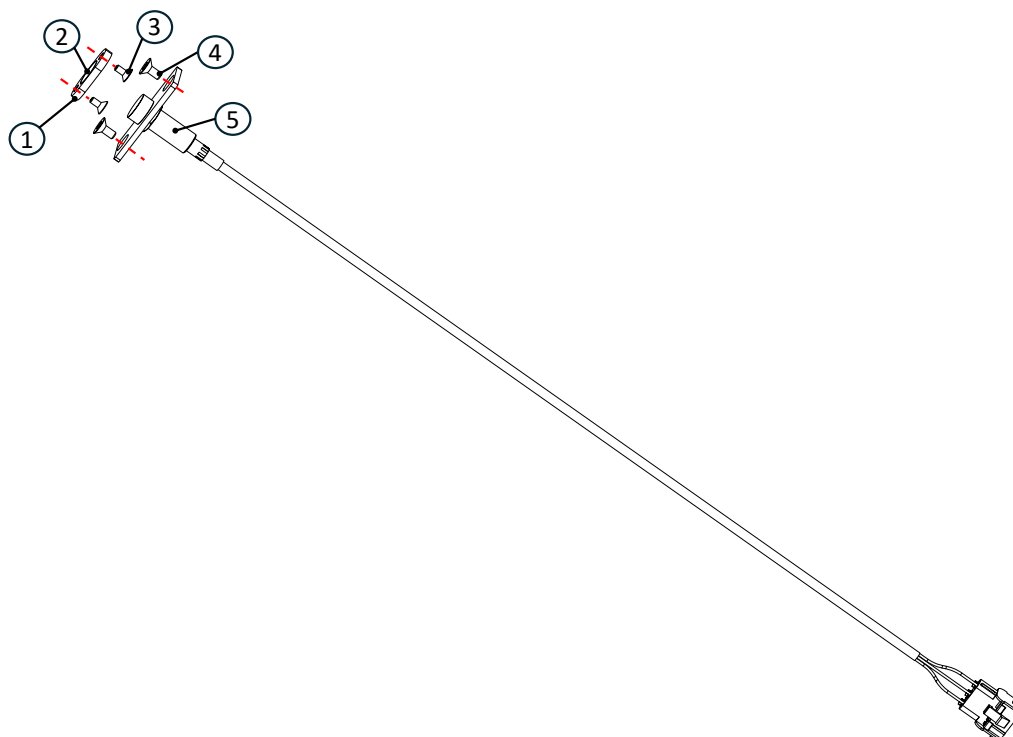

Position	Designation	Art.-Nr.	Pcs.
1	Retaining plate Magnet	E011011	1
2	Magnet	903324	1

Position	Designation	Art.-Nr.	Pcs.
3	Countersunk screw (M4x8)	800063	2
4	Countersunk screw (M5x10)	800184	2
5	BG Door contact switch	E011003	1

4.7.3.2 EINBAU DOOR CONTACT SWITCH

Position

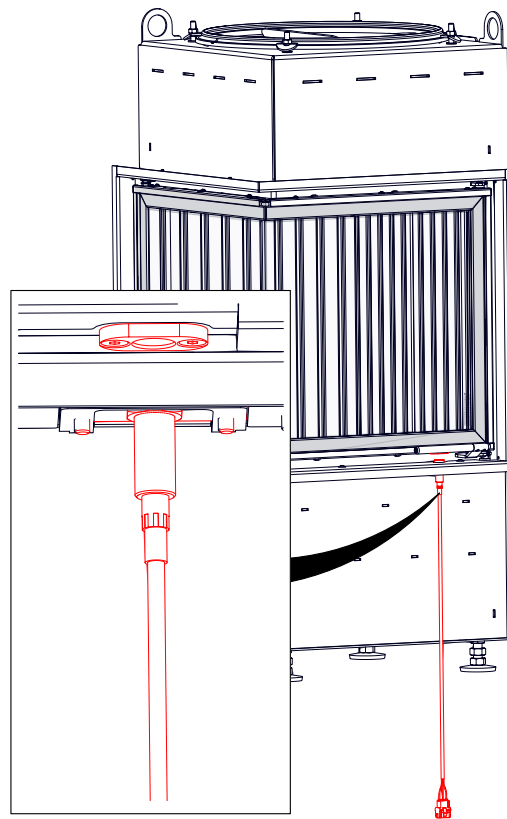

Workflow

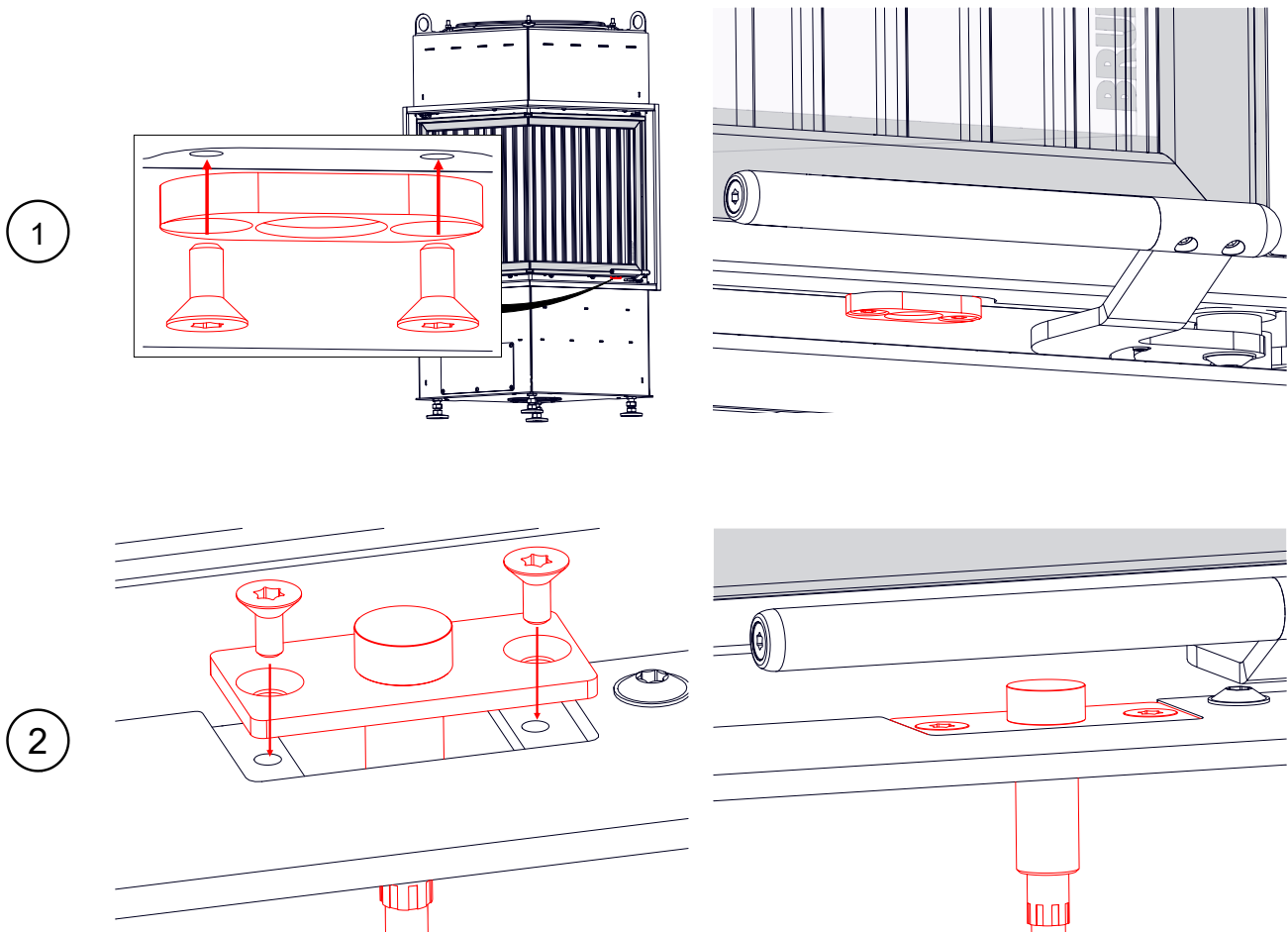

5 FRAME VARIANTS

NOTICE

Rahmen und Seitenteile müssen revisionierbar bleiben!

- Darauf achten, dass Rahmen und Seitenteile wie Blenden nach vollständigem Auf- und Einbau weiterhin revisionierbar sind! Diese Teile nicht verbauen bzw. einmauern.

5.1 DOOR FRAME (BKH WITH SIDE-OPENING DOOR)

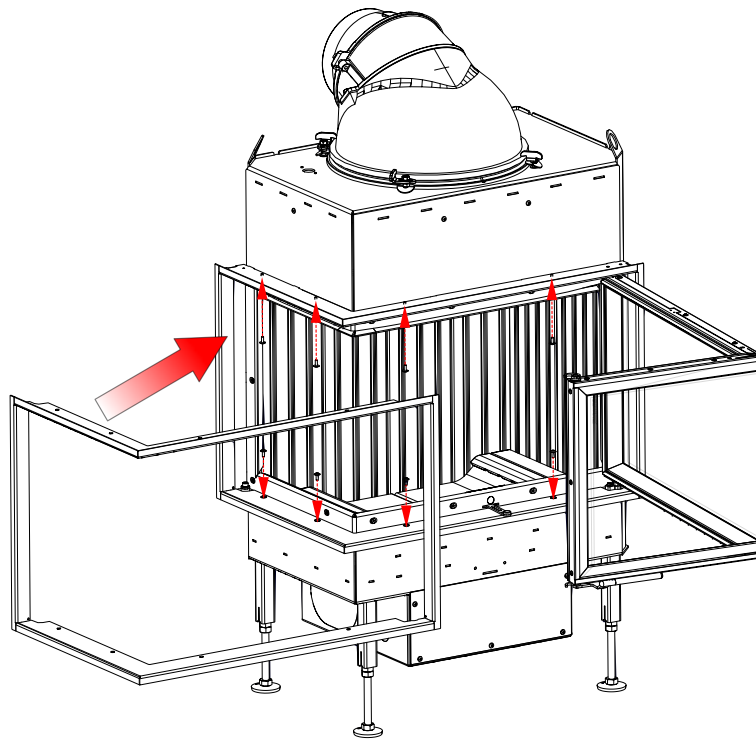

Im. 3: Summarised information

Workflow:

1

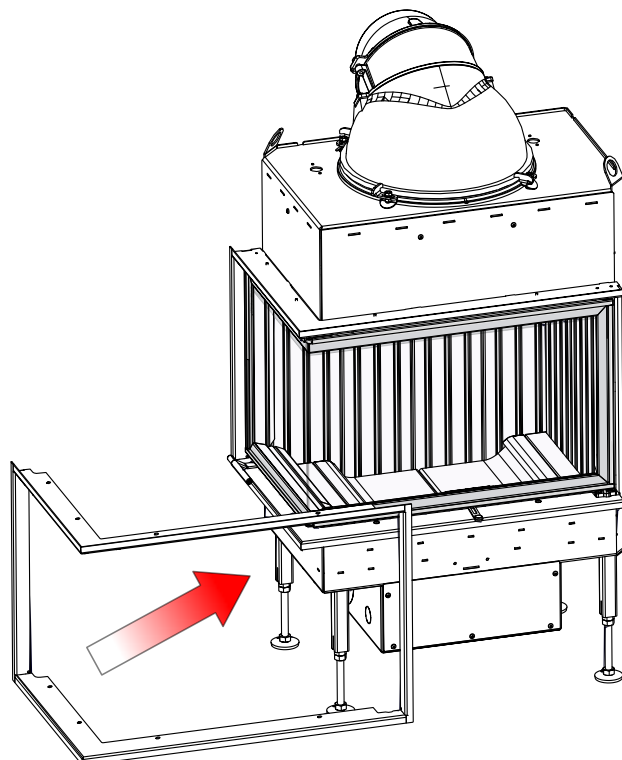

2

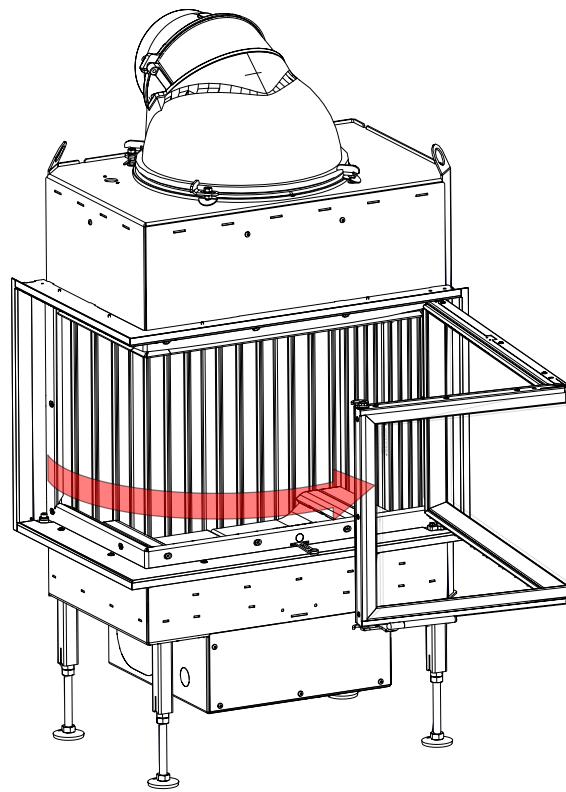

3

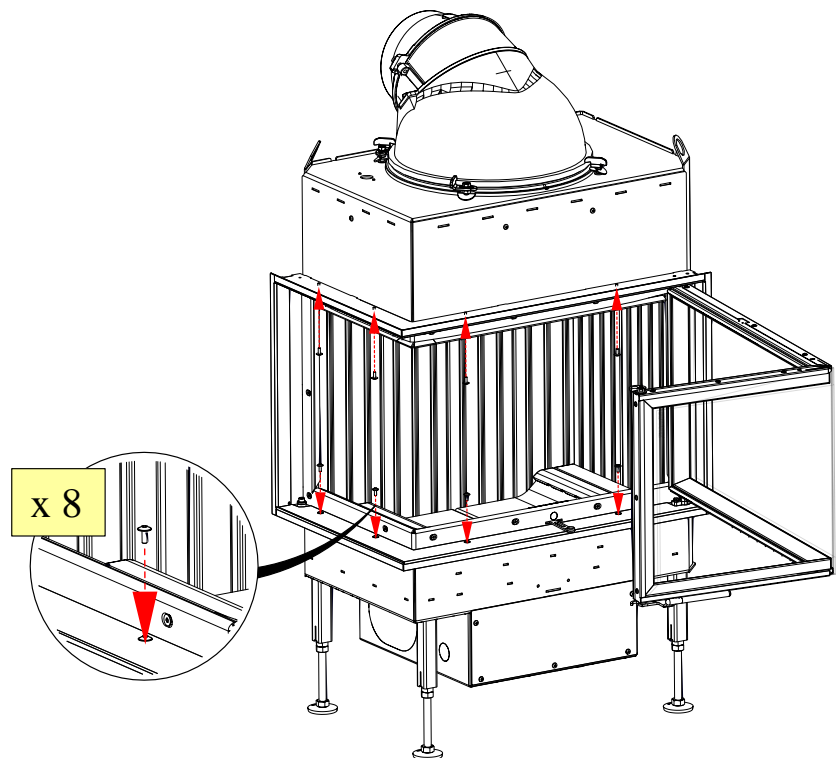

6 CONVERSIONS, SETTINGS

6.1 ADJUSTING OF SELF-CLOSING DOOR

Version : BKH with side-opening door

-> without self-closing self-closing

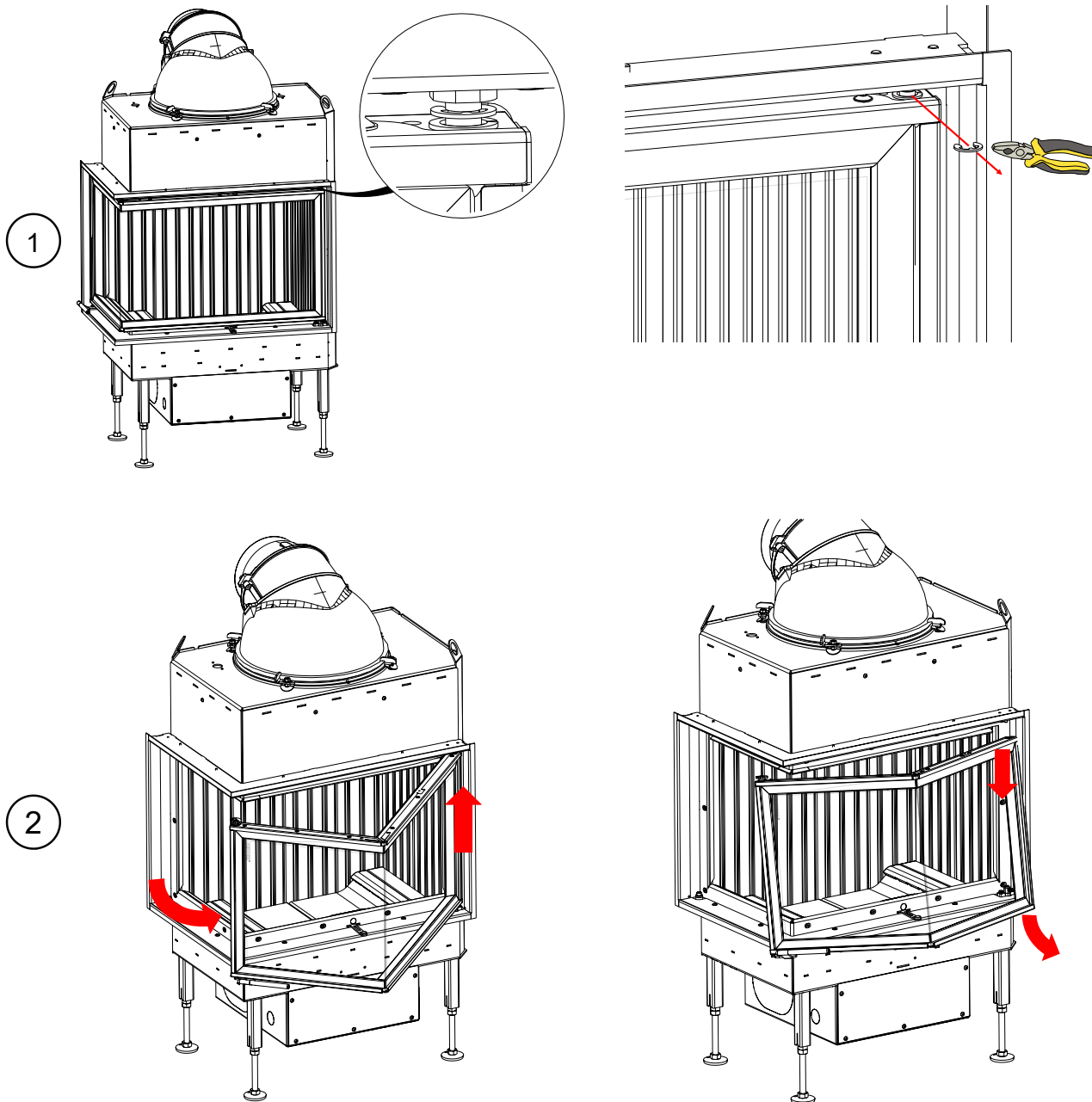

3

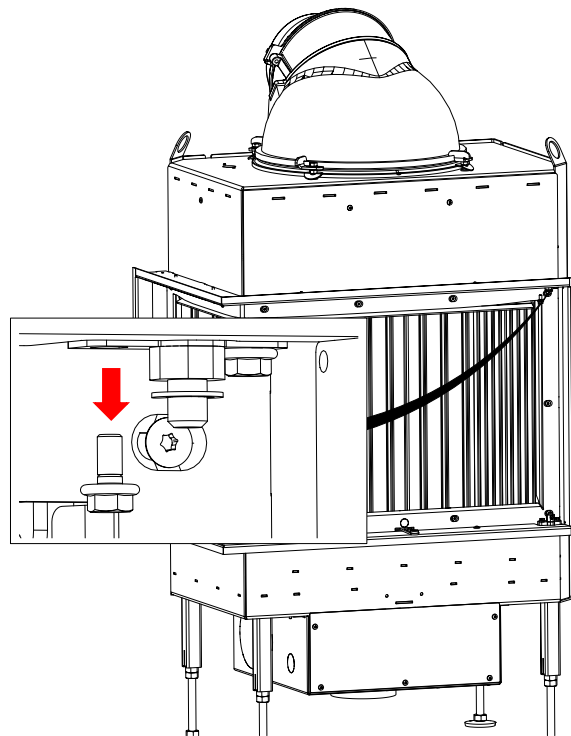

i

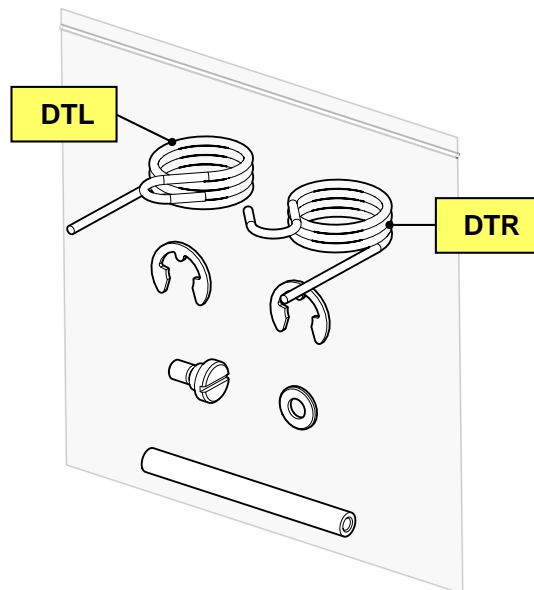

DTL = Hinged door side-opening door left side
DTR = side-opening door - right side

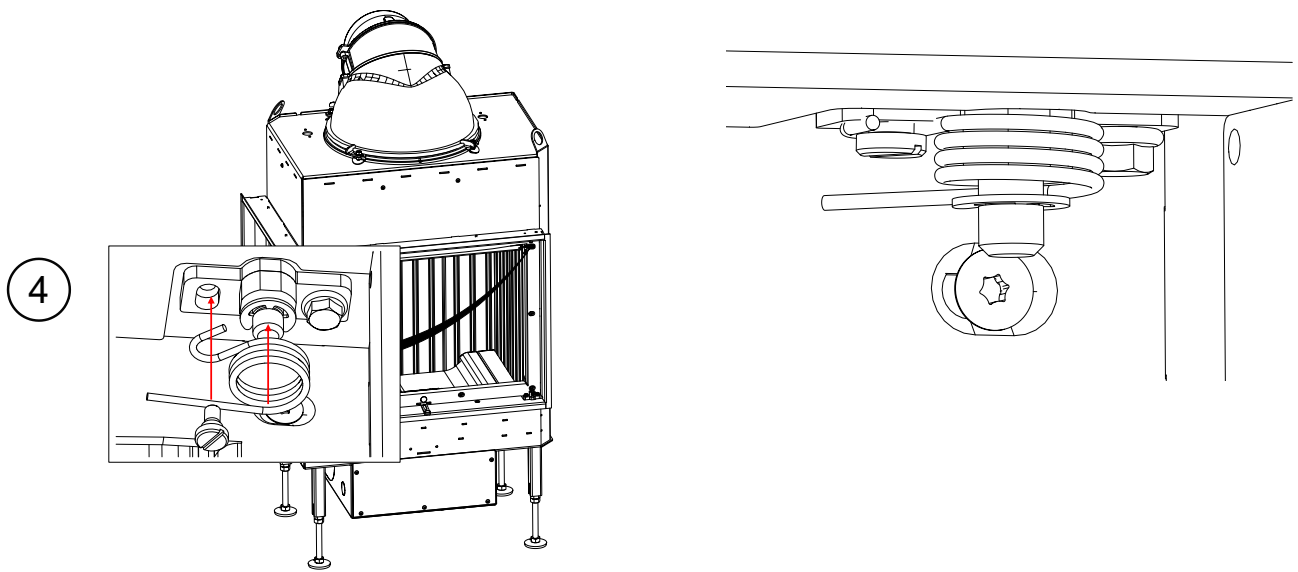

i AssemblyMounting aid:

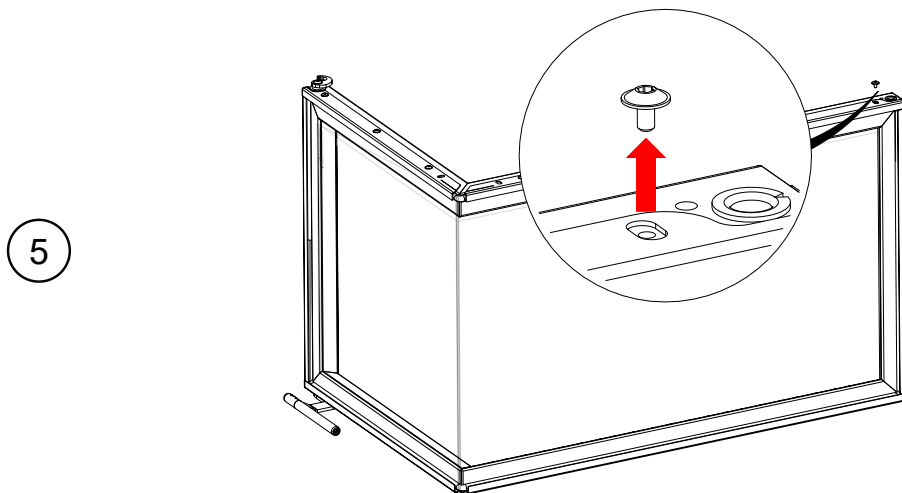
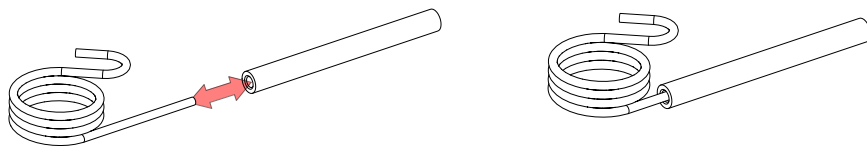

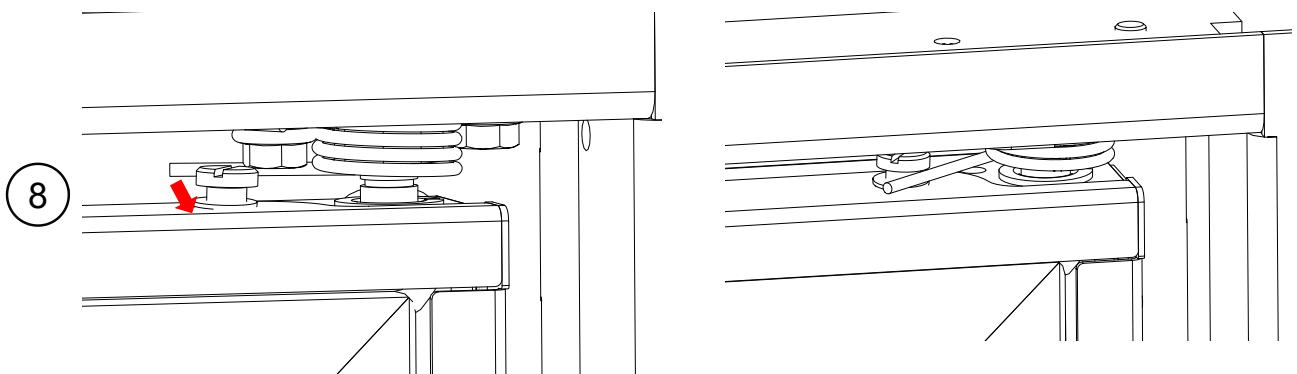
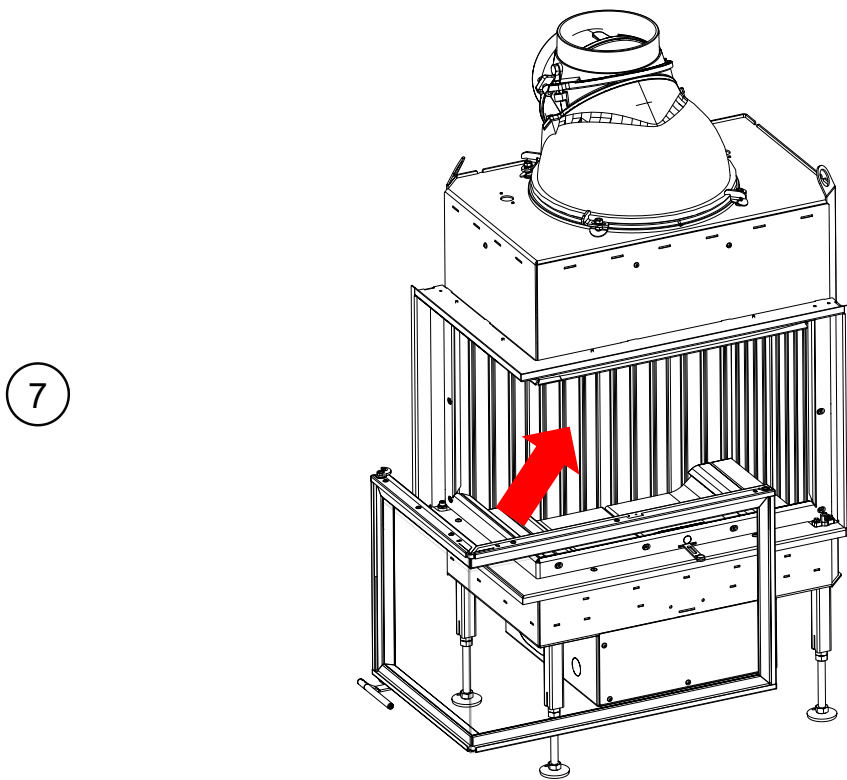
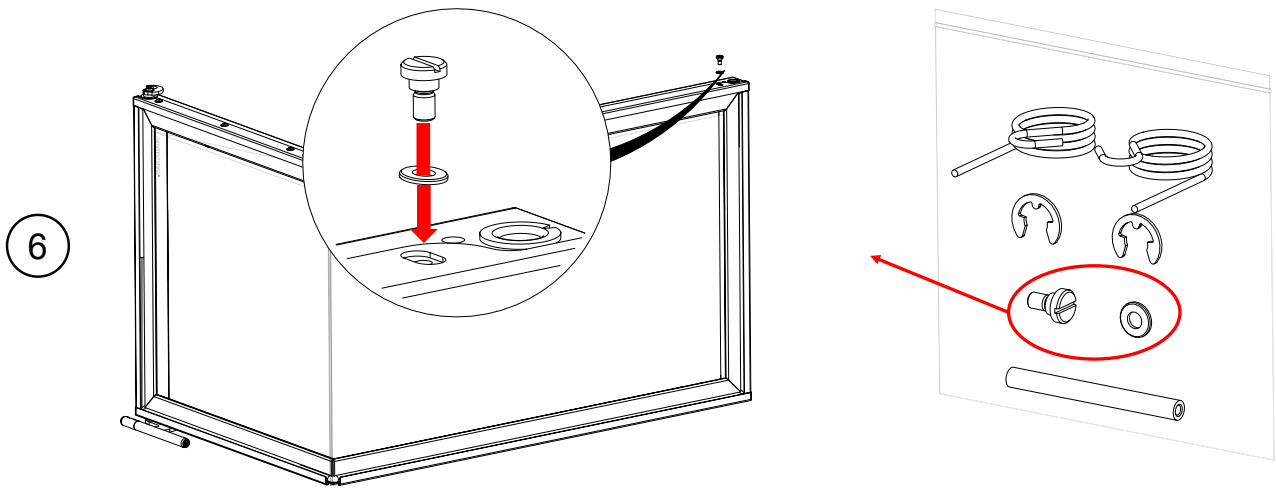



Installation Mounting aid:

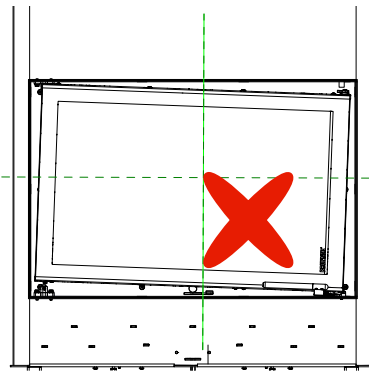
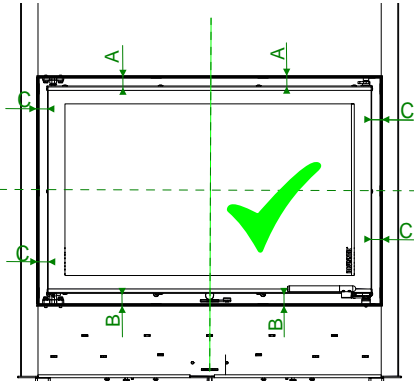
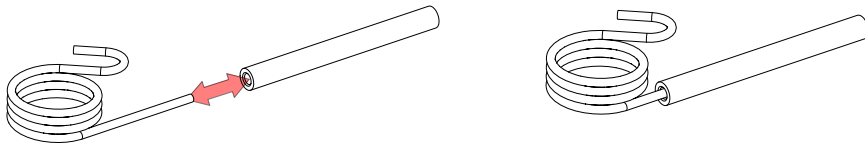

Adjust door!!!

The door must be aligned vertically and horizontally. When the door is closed, the sealing cord of the door must be tight to the body.

Version : BKH with lifting door

-> Self-closing is active in the delivery state..

7 DISPOSAL

Old equipment contains valuable materials that must be recycled. Observe the applicable national legal regulations for disposal.



Danger of electrocution.

Electrical connections of the furnace system are under mains voltage. This can lead to electric shock.

Switch off the power supply

Secure power supply against restart.

Old metal parts can be disposed of as metal recycling.

Electrical and electronic components must be disposed of as electronic waste. Fireclay linings can be disposed of as rubble.

Fireclay linings can be disposed of as rubble.

Dispose of insulating and insulating materials of the heating or fireplace insert in a closed container on a suitable waste disposal site.

Do not put the glass ceramic discs in the waste glass collection container! The glass panes can be disposed of as normal household waste.

Recycling of catalytic converters containing precious metals

Oxidative catalytic converters, as installed in modern wood stoves, are very effective at reducing emissions of carbon monoxide and hydrocarbons. This is possible, because precious metals like platinum, palladium and rhodium are used on the surface of catalytic converters. These precious metals are distributed very evenly in very small amounts on the surface of catalytic converters. Over the years, the abrasive effect of particles streaming through the catalytic converter will cause the partial diminishing of the coating containing precious metals. Continuous overheating of catalytic converters ($T > 700\text{ °C}$) will damage the coating. In certain cases, the catalytic converter should be replaced and a new converter must be installed to ensure the catalytic effect.

Used catalytic converters are suitable for re-use. Even if they are broken or damaged, they are suitable for recycling.

Contained precious metals can be recovered by thermal or chemical separation techniques to almost 90%, and then used again in the manufacturing process.

Please bring the used catalytic converter to a recycling center.

Thank you very much for your efforts in supporting the protection of environment and sustainable use of resources.

Dimension sheets - BKH corner 42-42-42 green

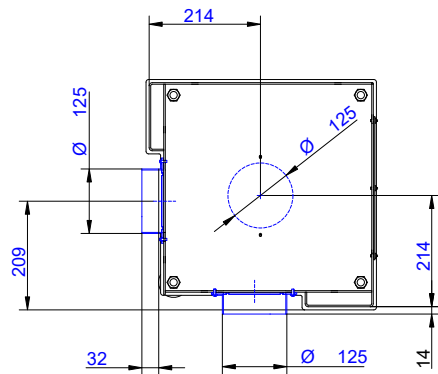
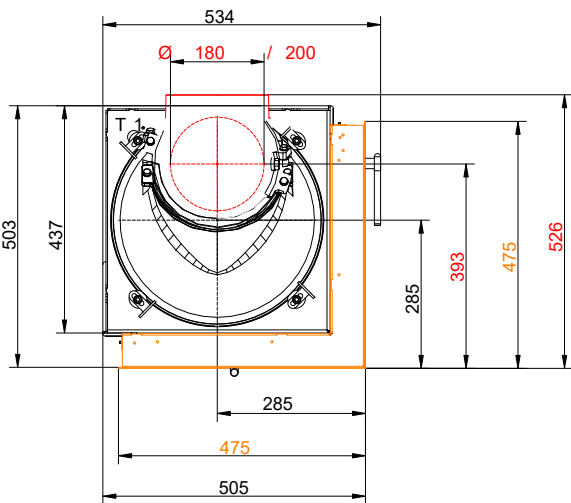
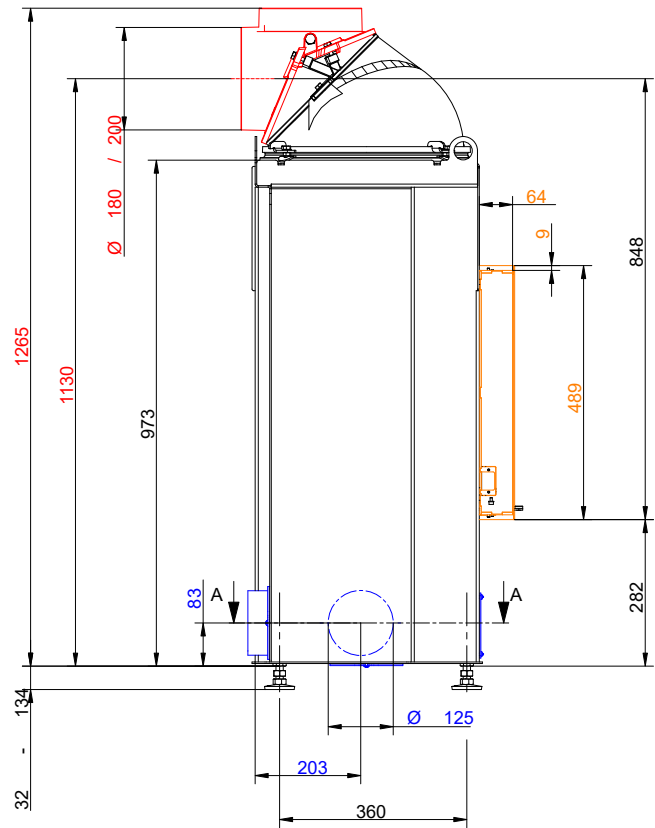
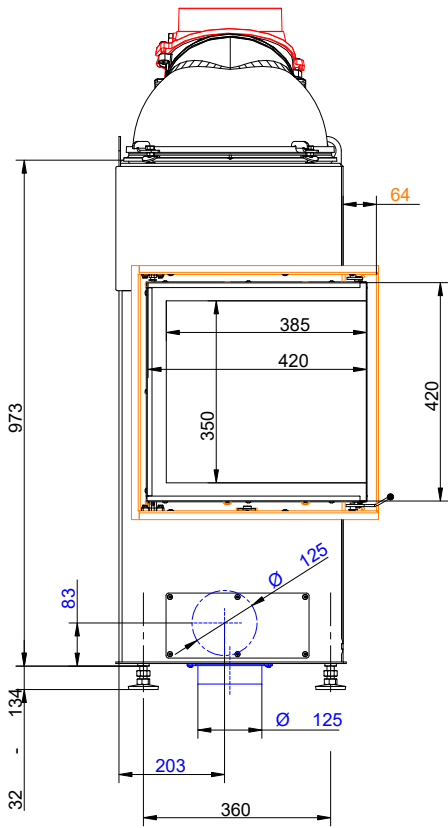

A - A

... mounting bracket and cast iron dome

Dimension sheets - BKH corner 42-42-42 green

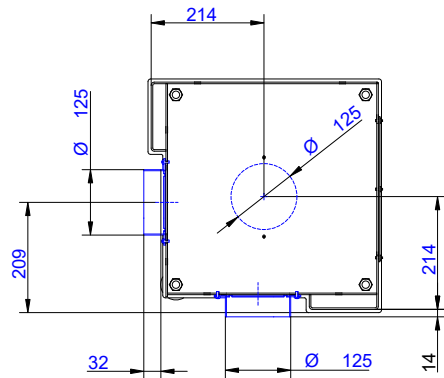
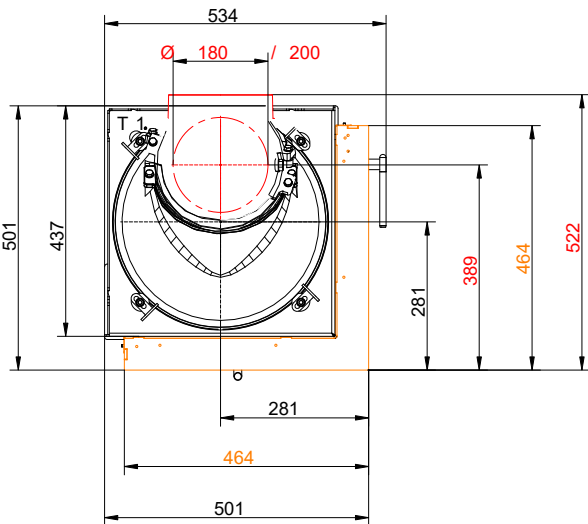
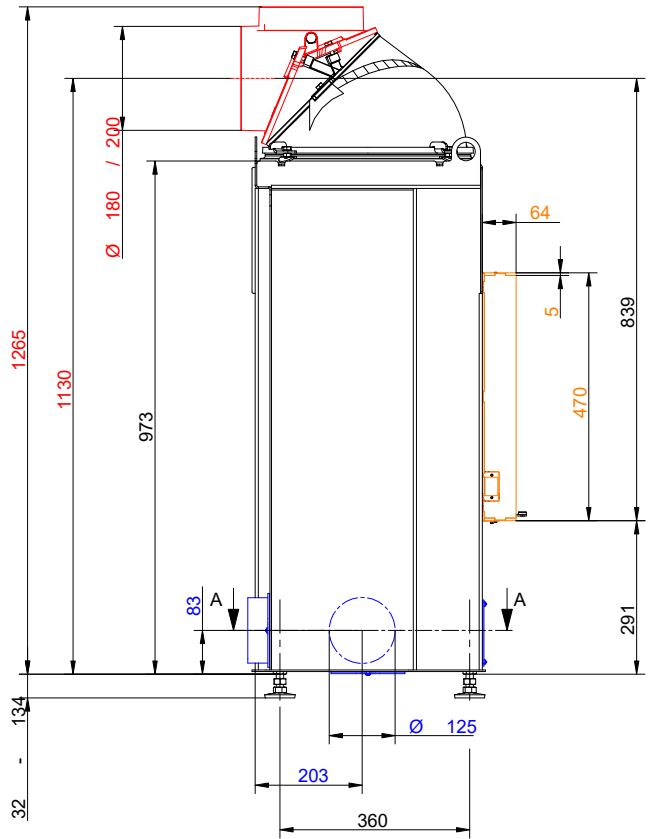
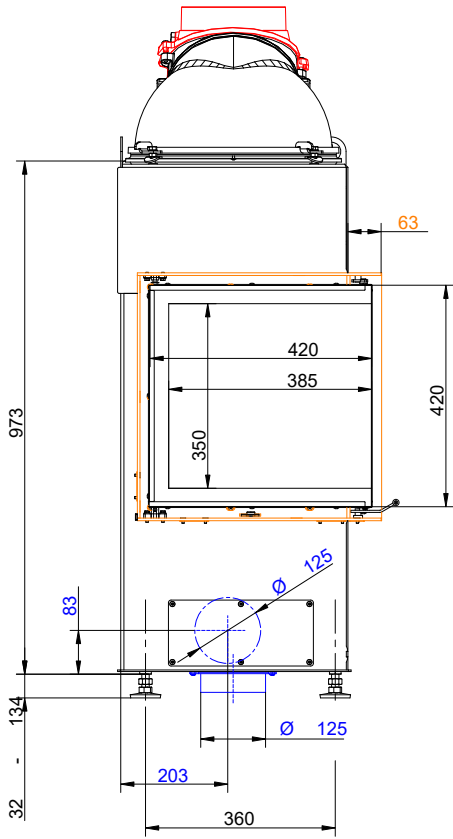

A - A

... door frame and cast iron dome

Dimension sheets - BKH corner 42-42-42 green

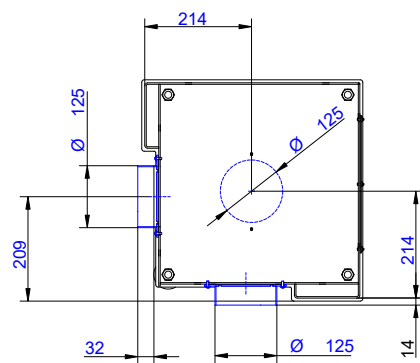
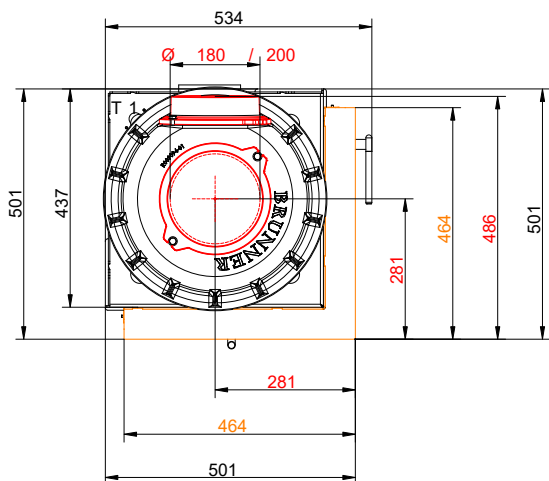
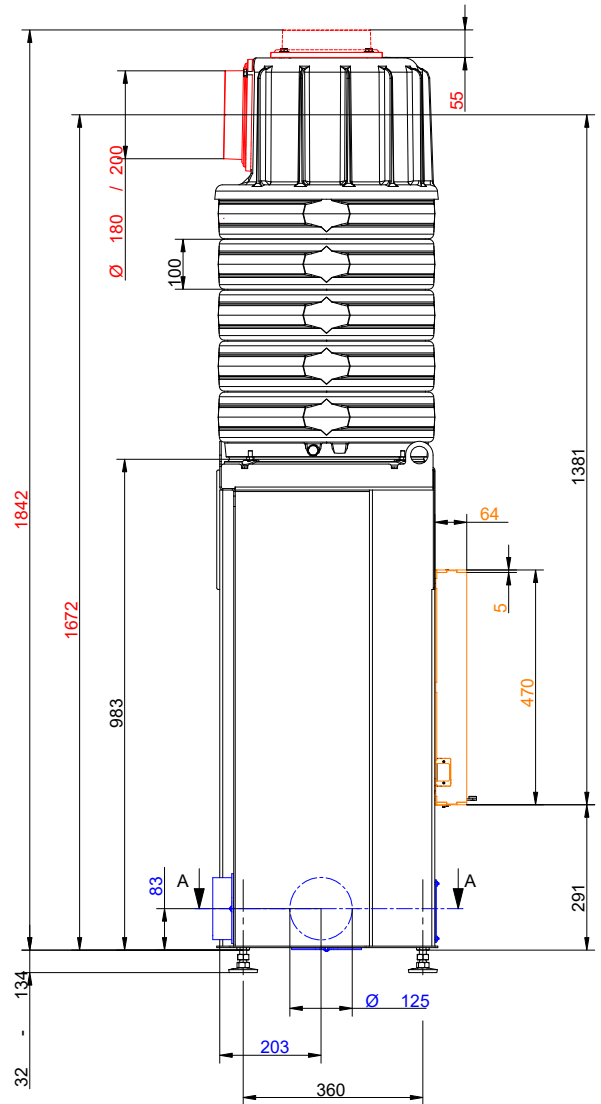
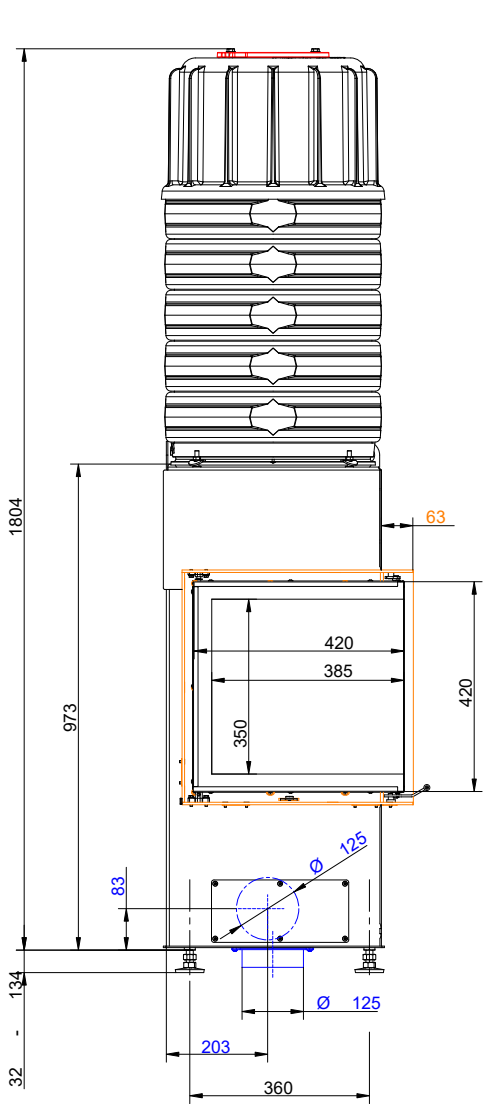

A - A

... mounting bracket and MAS

Dimension sheets - BKH corner 42-42-42 green

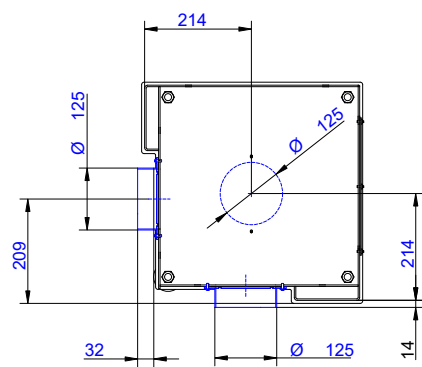
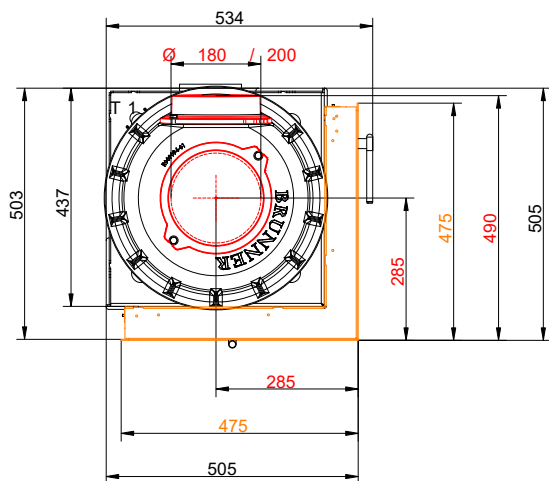
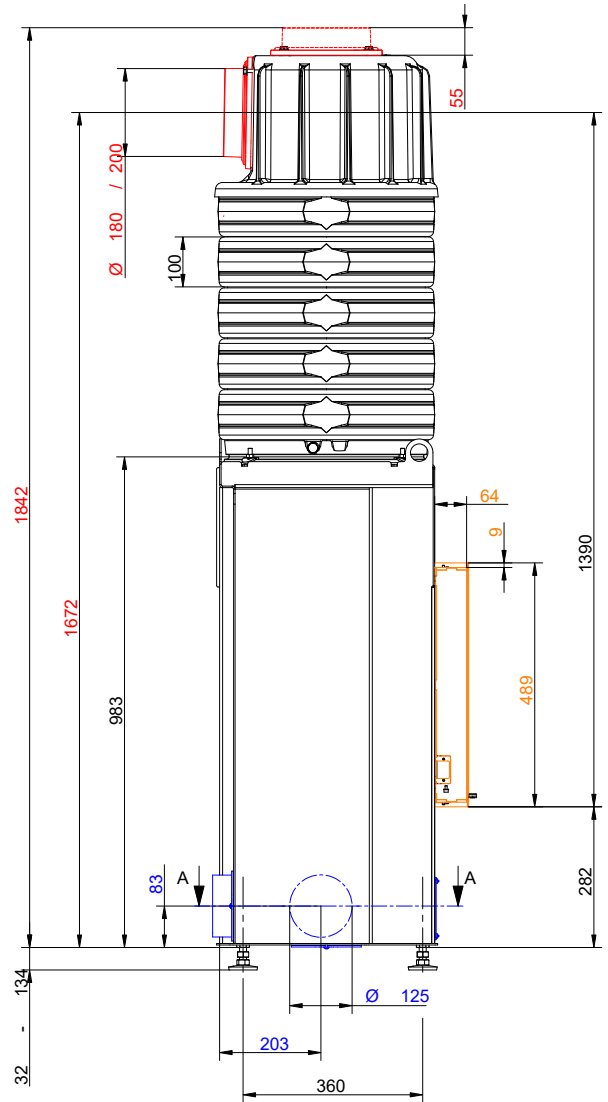
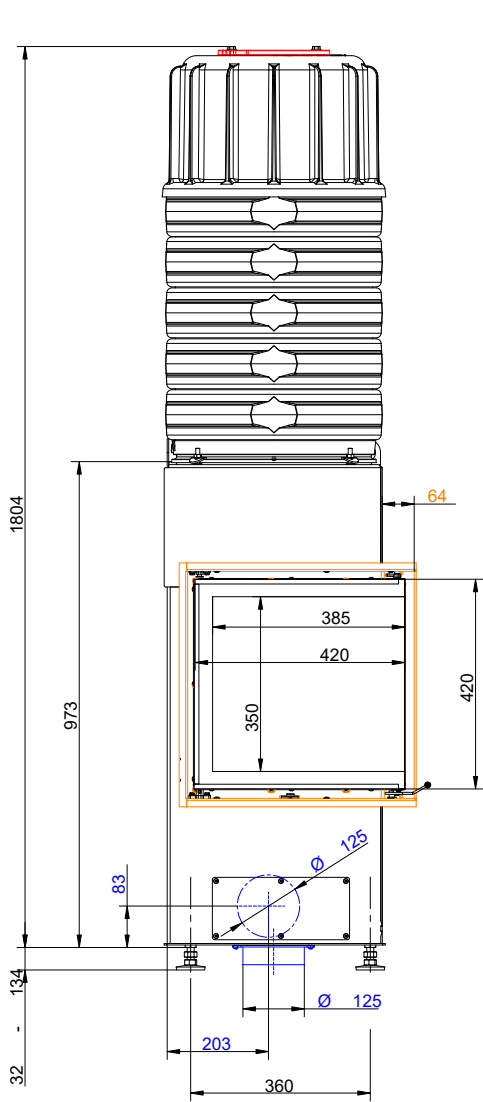

A - A

... door frame and MAS

Dimension sheets - BKH corner 42-42-42 green

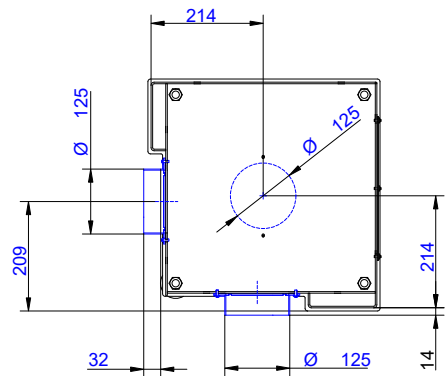
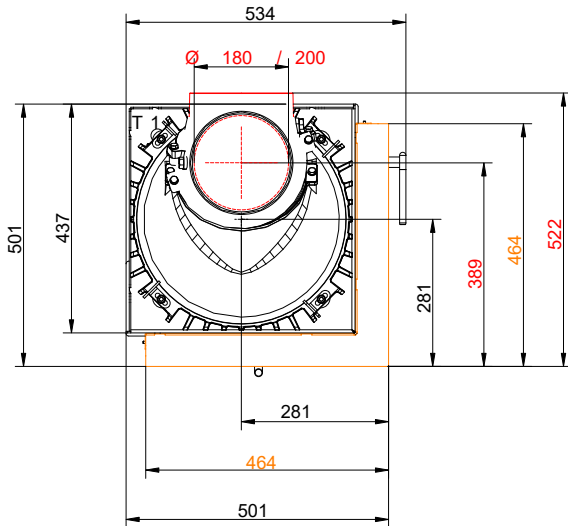
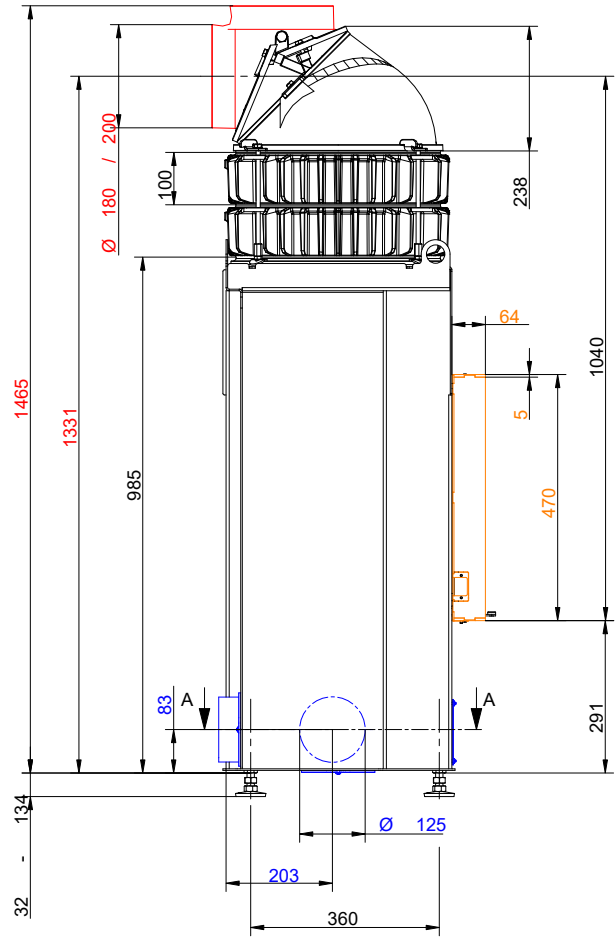
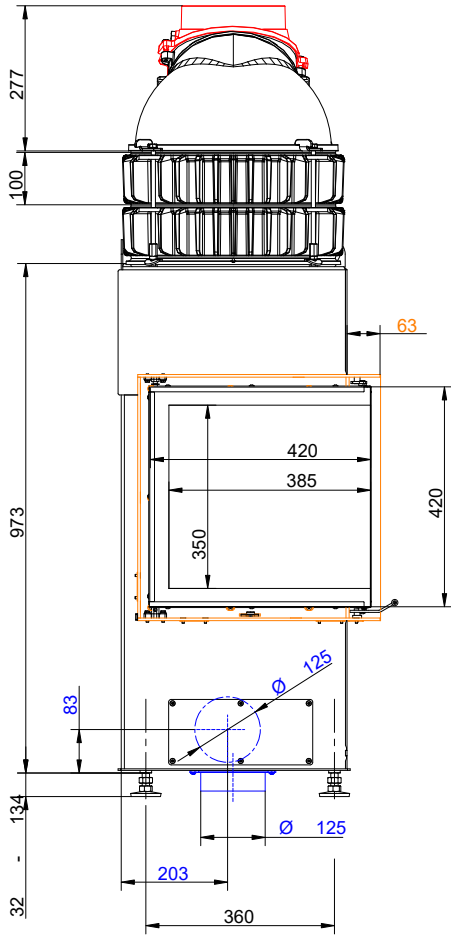

...mounting bracket and cast iron heat exchanger rings + dome

Planning and installation - BKH corner 42-42-42 green

Tested according to		EN 13229 W	EN 13229 WA
Values measured at		Rated power ¹⁾	Storage operation ²⁾
Data for functional demonstration			
Rated heat power	kW	7	-
Fire wood volume	kg/h	1.8	3.0
Combustion performance	kW	9	13
Flue gas mass flow	g/s	9	13
Flue gas temperature after:			
Cast iron dome	°C	220	350
2 x cast iron heat exchanger rings + dome	°C	200	290
5 x accumulation rings incl. MAS casted cover ³⁾	°C	-	260
2,0 m ceramic accumulator ⁴⁾	°C	-	180
1,4 m accumulation stones (MSS) ⁴⁾	°C	-	180
Necessary supply pressure	Pa	12	12
Fuel amount	kg	1.5	3.0
Combustion air consumption	m ³ /h	20	38
Combustion air connection Ø	mm	125	125
Heat distribution			
Insert / reheating surface	%	25 / 30	25 / 30
glass ceramic / glass ceramic coated (GKB)	%	45 / 35	45 / 35
Cross-section of gratings ⁵⁾			
exhaust warm air	cm ²	500	500
Recirculation air	cm ²	500	500
Minimal oven surface for closed construction type			
Heat dissipating surface	m ²	3.5	3.5
Minimal distances of the fireplace			
Heat protection panel for cladding, insulation layer	cm	3	3
to cladding, insulation layer	cm	5	5
to the floor (non-combustible)	cm	3	3
Fire protection with active rear ventilation, intermediate space			
Minimum insulation thickness for construction : insulation material 5 cm rear active ventilation wall ⁶⁾			
for mounting wall (combustible/non-combustible)	cm	5	5
Minimum insulation thickness for construction: insulation material 30 cm closed gap ceiling ⁷⁾			
for ceiling (combustible)	cm	10	10
Fire protection with adequate insulation material			
Minimum insulation thickness for construction: insulation material mounting wall, ceiling, floor ⁷⁾			
with heat protection panel, mounting wall (non-combustible) ⁸⁾	cm	6	6
with heat protection panel, mounting wall (combustible) ⁸⁾	cm	12	12
Mounting wall (non-combustible)	cm	8	8
Mounting wall (combustible)	cm	18	18
Ceiling (non-combustible)	cm	8	8
Ceiling (combustible)	cm	22	22
Floor (non-combustible)	cm	0	0
Minimum distances in front of the combustion chamber, glass ceramic / glass ceramic coated (GKB)			
for combustible parts	cm	≥ 120 / ≥ 80	≥ 120 / ≥ 80
Weight			
Fireplace insert + combustion chamber inner lining chamotte/cast iron	kg	105 + 44 / 52	
Meets requirement/limit values for:			

Planning and installation - BKH corner 42-42-42 green

EU / Germany

Ecodesign / 1. BImSchV (Stufe 2)

- 1) Indications to "Rated power" determined with 2 heat exchanger rings made of cast iron and Ø180 dome.
- 2) Indications to "Storage operation" for the manual execution of the reheating surface (guide values).
- 3) Damper flap recommended
- 4) Standard value or calculated functional proof required.
- 5) Air cross-sections if the specified nominal heat output is desired as the heat output.
- 6) Fire safety: Values determined with air cross-sections recorded for testing purposes; active rear ventilation, stove shell is heat emitting.
Insulation thickness 5 cm calcium silicate board (brands: Promasil, Silka, Skamol) and 5 cm active rear ventilation with diagonally positioned air circulation and supply air openings of 75 cm² (5x15 cm) each. For detailed design, see assembly instructions.
- 7) Fire safety: values determined in safety test with air cross-sections recorded for testing purposes; stove shell is heat emitting.
Information on replacement insulation material with calcium silicate boards (brands: Promasil, Silka, Skamol).
The specifications for non-combustible walls/ceilings and the structure with a closed gap (30 cm) correspond to the specifications of TROL (Germany), see assembly instructions.
- 8) Heat protection plate: accessory for BKH flat/tunnel/corner versions; factory-fitted for BKH panoramic fireplaces.

Product data sheet according to (EU) 2015/1186:

Supplier's name or trademark	Ulrich Brunner GmbH
Model identifier:	BKH 5.0 Eck 42-42-42 green DT
Energy efficiency class:	A+
Direct heat output:	7,0 kW
Indirect heat output:	N.A. kW
Energy efficiency index:	111,3
Fuel energy efficiency (at nominal heat output):	84,0 %
Fuel energy efficiency (at minimum load):	N.A. %
Special precautions: see supplied product documentation	

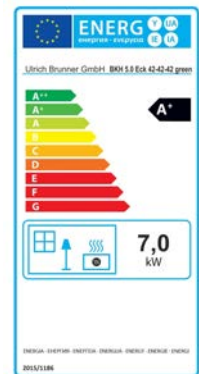
**Ulrich Brunner GmbH**

Zellhuber Ring 17-18

D-84307 Eggenfelden

Phone: +49 (0) 8721/771-800

E-Mail: info@brunner.de

Copyright

All information, drawings and technical descriptions contained in this documentation are our property and may not be reproduced without prior written permission.

® **BRUNNER** is a registered trademark.

Subject to technical changes and errors.

© by Ulrich Brunner GmbH

Doku-Nr.: 203009